

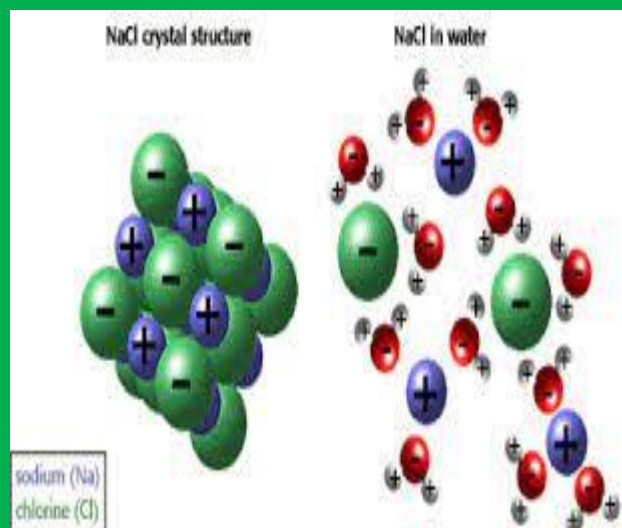

CHE(N)-101

B.Sc. I Semester FUNDAMENTAL CHEMISTRY-I

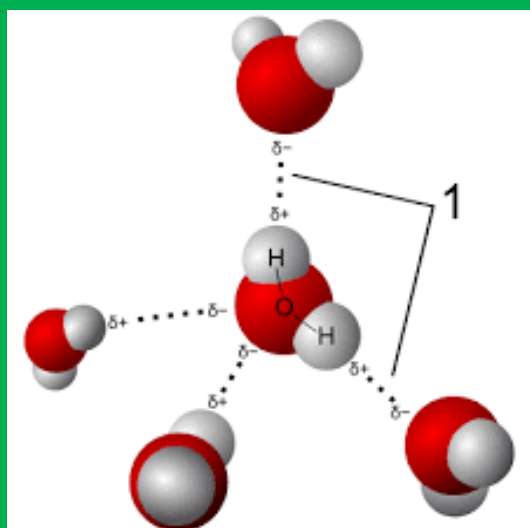

**DEPARTMENT OF CHEMISTRY
SCHOOL OF SCIENCES
UTTARAKHAND OPEN UNIVERSITY
HALDWANI (NAINITAL), UTTARAKHAND-263139**

CHE(N)-101

FUNDAMENTAL CHEMISTRY-I



**SCHOOL OF SCIENCES
DEPARTMENT OF CHEMISTRY
UTTARAKHAND OPEN UNIVERSITY
HALDWANI (NAINITAL)**

Phone No. 05946-261122, 261123

Toll free No. 18001804025

Fax No. 05946-264232, E. mail info@uou.ac.in

<http://uou.ac.in>

Board of Studies

Prof. P.D. Pant

Director, School of Sciences
Uttarakhand Open University
Haldwani, Nainital

Prof. G.C. Shah

Professor Chemistry
Department of Chemistry
Kumaun University, S.S.J. Campus,
Almora

Prof. P.P. Badoni

Professor Chemistry
Department of Chemistry
H.N.B. Garhwal University
Pauri Campus, Pauri

Prof. N.G. Sahoo

Professor Chemistry
Department of Chemistry
Kumaun University, D.S.B. Campus,
Nainital

Dr. Shalini Singh

Assistant Professor
Department of Chemistry
School of Sciences,
Uttarakhand Open University,
Haldwani (Nainital)

Dr. Vinod Kumar

Assistant Professor
Department of Chemistry
School of Sciences,
Uttarakhand Open University,
Haldwani (Nainital)

Dr. Deep Prakash

Assistant Professor
Department of Chemistry
School of Sciences,
Uttarakhand Open University,
Haldwani (Nainital)

Dr. Charu C. Pant

Assistant Professor (AC)
Department of Chemistry
School of Sciences,
Uttarakhand Open University,
Haldwani (Nainital)

Dr. Ruchi Pandey

Assistant Professor (AC)
Department of Chemistry
School of Sciences,
Uttarakhand Open University,
Haldwani (Nainital)

Programme Coordinator

Dr. Shalini Singh

Department of Chemistry
School of Sciences,
Uttarakhand Open University, Haldwani, Nainital

Unit Written By		Unit No.
1.	Dr. K. S. Dhani (Retd. Professor.) Department of Chemistry D.S.B. Campus, Kumaun University Nainital	01, 02, 03, 04
2.	Dr. K. B. Melkani (Retd. Professor) Department of Chemistry DSB Campus Kumaun University, Nainital	11, 12
3.	Dr. Vinod Kumar Assistant Professor Department of Chemistry, School of Sciences Uttarakhand Open University, Haldwani	13, 15, 16
4.	Dr. Deep Prakash Assistant Professor Department of Chemistry, School of Sciences Uttarakhand Open University, Haldwani	14
5.	Dr. Charu Chandra Pant Assistant Professor Department of Chemistry, School of Sciences Uttarakhand Open University, Haldwani	09,10
6.	Dr. Kamal K. Bisht Assistant Professor Department of Chemistry R.C.U. Govt. P.G. College, Uttarkashi	04,05
7.	Dr. Girdhar Joshi Assistant Professor Department of Chemistry Govt. P.G. College, Gopeshwar	06, 07
8.	Dr. Vipin Chandra Joshi Assistant Professor Department of Chemistry L.S.M. Govt. P.G. College, Pithoragarh	08

Course Editor

- 1. Dr. Vinod Kumar**
Assistant Professor
Department of Chemistry
School of Sciences,
Uttarakhand Open University, Haldwani, Nainital
- 2. Dr. Deep Prakash**
Assistant Professor
Department of Chemistry
School of Sciences,
Uttarakhand Open University, Haldwani, Nainital

Title :	: Fundamental Chemistry-I
ISBN No.:	:
Copyright	: Uttarakhand Open University
Edition	: 2023

Published by : Uttarakhand Open University, Haldwani, Nainital- 263139

CONTENTS

BLOCK-1: ATOMIC STRUCTURE AND CHEMICAL BONDING

Unit 1 :	Atomic structure	1-31
Unit 2 :	Periodic Properties	32-48
Unit 3 :	Chemical bonding –I	49-79
Unit 4 :	Chemical bonding –II	80-131

BLOCK-2: ORGANIC REACTION AND STEREOCHEMISTRY

Unit 5 :	Mechanism of organic reactions	132-160
Unit 6 :	Stereochemistry- I	161-191
Unit 7 :	Stereochemistry- II	192-218

BLOCK-3: ALIPHATIC HYDROCARBON

Unit 8 :	Alkane	219-242
Unit 9 :	Alkene	243-268
Unit 10 :	Alkyne	269-278

BLOCK-4: STATE OF MATTER

Unit 11 :	State of matter –I	279-324
Unit 12 :	State of matter –II	325-347

BLOCK-5: LAB WORK

Unit 13 :	Laboratory hazards and safety precautions	348-356
Unit 14 :	Inorganic exercise: Salt mixture analysis (I & II group)	357-399
Unit 15 :	Organic exercise: Stereochemistry and functional group analysis of organic molecules	400-414
Unit 16 :	Physical exercise: Determination of relative surface tension	415-421

UNIT 1 : ATOMIC STRUCTURE**CONTENTS:**

- 1.1 Introduction
- 1.2 Objective
- 1.3 Idea of de Broglie matter wave
- 1.4 Heisenberg's Uncertainty Principle
- 1.5 Schrodinger wave equation (No derivation)
 - 1.5.1 Significance of ψ and ψ^2
 - 1.5.2. Radial and angular wave functions
 - 1.5.3. Probability distribution curve
- 1.6. Shape of different orbitals
- 1.7. Quantum Numbers
- 1.8. Pauli's Exclusion Principles
- 1.9. Hund's rule of maximum multiplicity
- 1.10. Aufbau principle
- 1.11. Electronic configuration of the elements
- 1.12. Effective nuclear charge.
- 1.13. Summary
- 1.14. Terminal Questions
- 1.15. References

1.1 INTRODUCTION

In the beginning of nineteenth century, John Dalton (1766-1844) put forward his atomic theory, he regarded atom as hard and smallest indivisible particle of matter that takes part in chemical reactions; the atoms of one particular element are all identical in mass and atoms of different elements differ in mass and other properties.

Later on, various investigators around the end of nineteenth century and beginning of twentieth century did several experiments and revealed the presence of much smaller negatively charged particles, named electrons by J.J. Thomson (1897) and positively charged particles, named protons by Rutherford (1911) within an atom. These tiny particles were called subatomic particles. It was also established by Rutherford that the whole positive charge and most of the mass of an atom lies at nucleus. The positive charge on the nucleus was attributed to the presence of protons called the atomic number by Moseley (1912). The electrons were said to be arranged around the nucleus in the extra nuclear region in certain well defined orbits called energy shells and were said to be in constant motion (N. Bohr, 1913). Chadwick's experiments (1932) also revealed the existence of yet another subatomic particle in the nucleus which did not have any charge and named as neutrons. Further investigations established that there were also present some other subatomic particles in the nucleus in addition to electrons, protons and neutrons. These particles are positrons, neutrinos, antineutrinos, pions (π -mesons) etc. The pions (Yukawa, 1935) are said to be continuously consumed and released by proton-neutron exchange processes.

Thus, it is concluded that the atom no longer is an ultimate and indivisible particle of matter and the outer or valence shell electrons are responsible for chemical activity of the elements.

1.2 OBJECTIVE

In the present chapter you will be able to the :

- The preparation of the text of this unit is to acquaint the readers with the fascinating and exciting realm of the atoms. Accordingly, an attempt has been made to through light on the arrangement of the internal constituents of the atoms (the subatomic particles), their peculiarities and characteristics along with their behaviour towards their neighbour.
- The arrangement of protons and neutrons in the nucleus and the rules governing the arrangement of electrons in the extra nuclear region of an atom and filling of orbitals

belonging to higher energy shells prior to the entry of electrons in the orbitals of lower energy shells.

- At the same time, the problem “what makes the electron cloud to acquire different shapes in three dimensional space around the nucleus?” has been entertained and various other interesting problems have also been taken into account.
- In this unit you will be know about the quantum number and their type, De-broglie;s hypothesis and Heisenberg uncertainty principle.
- Under this unit you able to different type rule of the electronic configuration and arrangement of electron in the their particular orbital

1.3. DE-BROGLIE’S MATTER WAVES: DUAL NATURE OF MATTER

This is based on wave mechanical concept of an electron in an atom. Albert Einstein proposed dual character of electromagnetic radiation in 1905, *viz.* wave character based on Maxwell’s concept evidenced by diffraction, interference, polarisation kinds of phenomena and particle character based on Planck’s quantum theory witnessed by quantization of energy and hence photoelectric effect, i.e. the ejection of photo electrons from metal surface on striking electromagnetic radiation.

On the basis of above analogy, French Physicist Louis de Broglie (1924) postulated that not only light but all material objects (both micro and macroscopic) in motion such as electrons, protons, atoms, molecules etc. possess both, wave and the particle properties and thus have dual character, i.e. the wave character and particle (corpuscular) character. He called the waves associated with material particles as matter waves which are now named de Broglie’s wave. These waves differ from electromagnetic or light waves in a sense that these are unable to travel through empty space and their speed is different form light waves.

de Broglie’s relation

de Broglie deduced a fundamental relation between the wave length of moving particle and its momentum by making use of Einstein’s mass energy relationship and Planck’s quantum theory. The material particle as a wave satisfies the Planck’s relation for a photon, i.e.

$$E = h\nu \quad \dots\dots\dots (1.1)$$

where h is Planck's constant and ν is the frequency of the wave. The frequency for light wave, $\nu = \frac{c}{\lambda}$ and for particle wave, $\nu = \frac{v}{\lambda}$ (c = speed of light wave and v = speed of particle wave).

At the same time, Einstein's mass energy relationship is applicable to it, i.e.

$$E = mc^2 \text{ (for a photon)} \quad \dots\dots\dots (1.2)$$

or
$$E = mv^2 \text{ (for a particle where } v \neq c) \quad \dots\dots\dots$$

 (1.3)

where m is the mass and v the speed/velocity of the particle. From the equations 1.1 and 1.3, we have

$$h\nu = mv^2 \quad \dots\dots\dots (1.4)$$

or
$$\frac{h\nu}{\lambda} = mv^2$$

or
$$\frac{h}{\lambda} = mv = p \text{ (momentum)}$$

or
$$\lambda = \frac{h}{p} \text{ or } \left(\frac{h}{mv}\right) \quad \dots\dots (1.5)$$

(momentum $p = mv$, mass x velocity)

Here, λ corresponds to the wave character of matter and p its particle character. This is known as de Broglie's relation. From this relationship, it is concluded that "the momentum of a moving particle is inversely proportional to the wavelength of the wave associated with it".

It is important to note here from above discussion that de Broglie's relation is applicable to material particles of all sizes and dimensions but the wave character is significant only for micro objects like electrons and is negligible for macro objects hence cannot be measured properly. This infers that de Broglie's relation is more useful for smaller particles.

de Broglie's relation has been applied to a moving electron around a nucleus in a circular path in an atom to justify Bohr's postulate which states that electrons can move only in those orbits for which the angular momentum is equal to an integral multiple of $\frac{h}{2\pi}$, i.e.

$$mvr = n\frac{h}{2\pi} \quad \dots\dots\dots(1.6)$$

This moving electron is considered as a standing wave extended around the nucleus in circular path and not as a mass particle. If the circumference of the orbit is an integral multiple of the wave length, λ ,

i.e.
$$2\pi r = n \lambda \quad \dots\dots\dots(1.7)$$

where r is the radius of the orbit and n is the whole number, the wave remains continually in phase, i.e. is a merging wave (Fig. 1.1 a)

From equation 1.5, we have

$$\lambda = \frac{h}{p} = \frac{h}{mv}$$

Putting the value of λ in equation 1.7, we get

$$2\pi r = n \frac{h}{mv} \text{ Fig 1.1 (a) merging waves, (b) Crossing waves}$$

or
$$mvr = n \frac{h}{2\pi} \text{ (on rearranging)} \quad \dots\dots\dots(1.8)$$

which is the same as equation 1.6, i.e. Bohr's postulate mentioned above. If the circumference of the orbit is bigger or smaller than the value given above, the wave is out of phase, i.e. a crossing wave (Fig. 1.1 b)

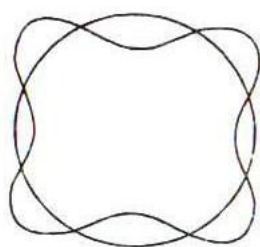

Fig. 1.1 a: in phase

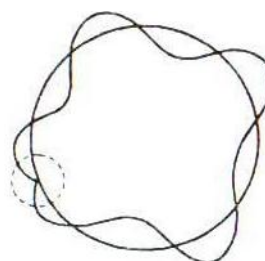

Fig. 1.1 b: out of phase

de Broglie's concept has been experimentally verified by Davisson and Germer, G.P. Thomson and later by Stern independently.

1.4. HEISENBERG'S UNCERTAINTY PRINCIPLE

According to classical mechanics, a moving electron behaves as a particle whose position and momentum could be determined with accuracy. But according to de Broglie, a moving electron has wave as well as particle character whose precise position cannot be

located because a wave is not located at a particular point rather, it extends in space. To describe the character of a subatomic particle that behaves like a wave, Werner Heisenberg in 1927 formulated a principle known as Heisenberg's Uncertainty Principle. According to the principle *“it is impossible to determine simultaneously both the position as well as the momentum (or velocity) of a moving particle at the same time with certainty (or accurately)”*

He also proposed a mathematical relationship for the uncertainty principle by relating the uncertainty in position with the uncertainty in momentum which is given below:

$$\Delta x \Delta p \geq \frac{h}{4\pi} \dots\dots\dots(1.9)$$

or
$$\Delta x \times m (\Delta v) \geq \frac{h}{4\pi} \text{ (since } p = m v \text{ and } \Delta p = m \Delta v \text{)}$$

(1.10)

where Δx is the uncertainty or error in the position of the particle, Δp and Δv are the uncertainties in its momentum and velocity and h is Planck's constant.

This equation states that the product of Δx and Δp can either be greater than or equal to (\geq) but never smaller than $\frac{h}{4\pi}$, a constant. If Δx is measured more precisely (i.e. Δx is small) then there is large uncertainty or error in the measurement of momentum (Δp is large) and vice versa.

1.5. CONCEPT OF PROBABILITY AND SCHRODINGER'S WAVE EQUATION

From the uncertainty principle, it has been concluded that the exact position and exact momentum or velocity (related to kinetic energy) of a micro particle can be replaced by the concept of probability. For an electron in an atom we can say that there is probability of finding it in a particular region of space and in a particular direction (except for s-electron).

To describe the wave motion of electron in hydrogen atom, Schrodinger in 1927 combined the de Broglie's relation for the wavelength of a particle wave with the well known differential equation for standing waves and proposed a mathematical form called Schrodinger's wave equation. This equation is now widely used to explain the behaviour of

atomic and molecular systems. The equation for a single particle in three dimensional space, i.e. along x, y and z directions is given as follows:

$$\frac{\delta^2 \psi}{\delta x^2} + \frac{\delta^2 \psi}{\delta y^2} + \frac{\delta^2 \psi}{\delta z^2} + \frac{4\pi^2}{\lambda^2} \psi = 0 \quad \dots\dots\dots(1.11)$$

In place of three partial differentials, symbol '∇' (del) can be used, hence the above equation becomes

$$\nabla^2 \psi + \frac{4\pi^2}{\lambda^2} \psi = 0 \quad \dots\dots\dots(1.12)$$

where ∇² (del square) is equal to $\frac{\delta^2}{\delta x^2} + \frac{\delta^2}{\delta y^2} + \frac{\delta^2}{\delta z^2}$ and is known as laplacian operator.

Putting the value of λ from de Broglie's relation (i.e. $\lambda = \frac{h}{mv}$), the above equation becomes

$$\nabla^2 \psi + \frac{4\pi^2 m v^2}{h^2} \psi = 0 \quad \dots\dots\dots(1.13)$$

Extracting the value of v from kinetic energy, potential energy and total energy terms i.e. E = K.E+V where K.E. = $\frac{1}{2} m v^2$ and putting in the above equation, we get the final form of the equation as:

$$\nabla^2 \psi + \frac{8\pi^2 m}{h^2} (E - V) \psi = 0 \quad \dots\dots\dots(1.14)$$

This equation is known as Schrodinger's wave equation.

1.5.1. Significance of ψ and ψ²

An electron, from the probability concept, is considered as a three dimensional wave system extended around the nucleus and is represented by the symbol ψ which denotes the wave function of the electron; ψ itself has no physical significance and simply represents the amplitude of electron wave. Schrodinger's equation has several solutions for ψ, both real and imaginary. Some of the real values of ψ are appreciable while others are too small and hence neglected. If the value of ψ obtained as above is continuous, finite, single valued and electron probability in space related to ψ is equal to 1, then ψ is known as eigen function (meaning characteristic), ψ² gives the probability of finding an electron of a given energy, E from place to place in a given region around the nucleus. Since, ψ often contains the imaginary quantity,

but the probability of an electron in a given volume must be a real quantity, therefore the product $\psi \psi^*$ (ψ star) is used rather than ψ^2 where ψ^* is complex conjugate of ψ . This product will always be real whereas ψ^2 may be real or imaginary. If ψ is real quantity, then ψ and ψ^* both are same and hence ψ^2 is also a real quantity and corresponds to probability density per unit volume.

1.5.2. Radial and angular wave functions:

The radial wave function, R (r)

The value of ψ appearing in Schrodinger's wave equation in polar coordinates, (r, θ, ϕ) , can be determined only when ψ is written in the following form (mention of equation is not required) :

$$\Psi (r, \theta, \phi) = R (r) \Theta(\theta) \Phi(\phi) \quad \dots\dots\dots(1.15)$$

Where $\psi (r, \theta, \phi)$, is known as total wave function, R (r) is the radial wave function and other two are angular wave functions. The radial wave function, R (r) is dependent on r only where r is the distance of electron from the nucleus and is independent of θ and ϕ . Therefore, R (r) deals with the distribution of the electron charge density as a function of distance (r) from the nucleus. R (r) depends on two quantum numbers n and l and can be denoted as $R_{n,l} (r)$ or simply $R_{n,l}$. Both $R_{n,l}$ and $R_{n,l}^2$ are significant only for drawing the probability curves for various orbitals. The radial wave functions for all s-orbitals are spherically symmetrical.

The angular wave function, $\psi (\theta, \phi)$.

The angular wave functions depend on the angles θ and ϕ and are independent of the distance (r). As given above in equation 1.15, these are represented as $\Theta (\theta)$ and $\Phi (\phi)$. Their values depend on the quantum numbers l and m and can be written as $\Theta_{l,m}$ and Φ_m , respectively. Therefore, the equation 1.15 can also be written as

$$\Psi_{n,l,m} = R_{n,l} \Theta_{l,m} \Phi_m \quad \dots\dots\dots(1.16)$$

This equation shows that the total wave function besides depending on r, θ , ϕ , also depends on the quantum numbers viz., n, l and m. Each permitted combination of n, l and m gives a distinct wave function and hence a distinct orbital.

The angular wave functions together are used to predict the shapes of the orbitals.

1.5.3. Probability distribution curves:

Before discussing the distribution curves, let us know about the electron probability function. The probability or the chance of finding an electron in three dimensional space round the nucleus is known as electron probability function, D. For an extremely small spherical shell of radius r and thickness dr round the nucleus, the value of D can be given by

$$D = \psi^2 \times \text{volume of shell} = \psi^2 \times 4\pi r^2 dr \quad \dots\dots\dots (1.17)$$

and the electron probability between r = 0 and r = r would be equal to

$$\int_{r=0}^{r=r} \psi^2 \cdot 4\pi r^2 dr. (\psi^2 = R^2(r) \quad \text{or} \quad R^2_{n,l})$$

Radial probability distribution curves

The square of the radial wave function multiplied by a volume element, dv, i.e. R²(r) x dv measures the probability of locating an electron at a distance from the nucleus and within a small radial space. This is same as electron probability function given above in which ψ² can be replaced by R²_{n,l}, meaning radial distribution. When R²(r). dv or R²_{n,l}. 4πr² dr where dv= 4πr² dr, is plotted against r, the distance from nucleus, we get radial probability distribution curves. The peak of the curve gives the distance from the nucleus where the probability is maximum and at distances smaller or greater than this, value of probability is less but not zero. Thus, it is observed that electron charge density decreases but volume of shell increases with r. Various such curves are shown below:

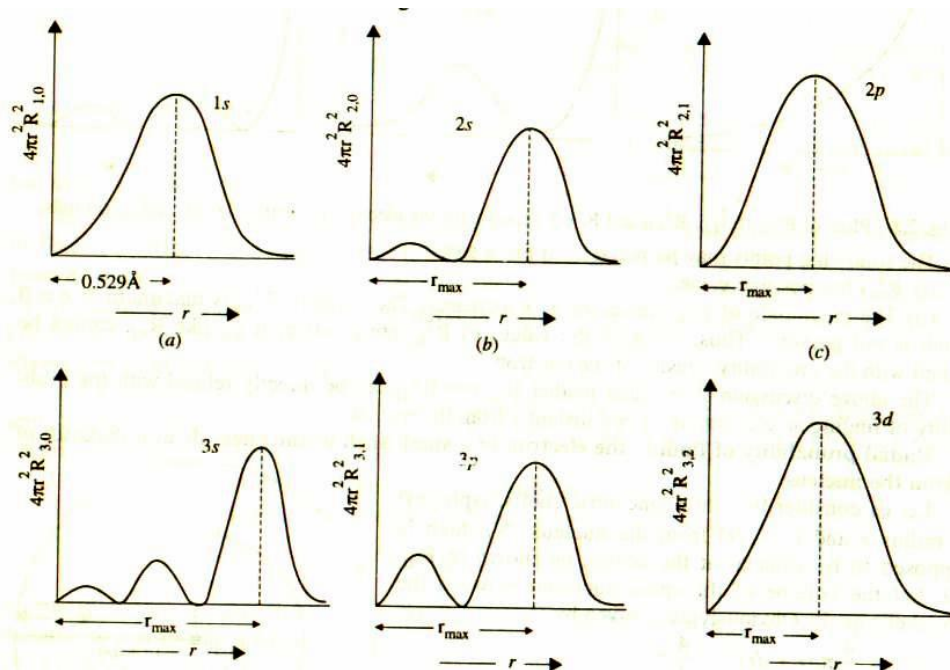

Fig. 1.2 Radial Probability distribution curves for 1s,2s,2p,3s,3p and 3d-orbitals. Simple sketches have been given in which the values of n and l have been shown and d_r has been omitted.

The important features of these curves are;

(i). Curves start from the origin and the areas covered by the envelopes of a particular curve for a subshell (orbital) go on increasing from left to right so that the area of the last envelope is maximum.

(ii). The number of minima where density of electronic charge is zero, appearing in a particular curve gives the number of radial nodes or nodal points for the orbital (subshell). The number of nodal points is equal to $n-l-1$. Thus for the electrons of 1s,2s,2p,3s,3p and 3d orbitals, the number of nodal points is 0,1,0,2,1 and 0, respectively. This is also evident from the curves of these orbitals. Evidently, 3s orbital (nodal points = 2) is bigger in size and more diffused than 1s (nodal point = 0) and 2s orbitals (nodal point = 1) both due to greater number of nodal points in it (see figure 1.2)

1.6. SHAPES OF ATOMIC ORBITALS AND ANGULAR PROBABILITY DISTRIBUTION CURVES

The shapes of atomic orbitals depend θ and ϕ i.e. the product $[\Theta(\theta) \times \Phi(\phi)]$ or $\Theta_{l,m} \times \Phi_m$ is related with the shapes of the orbitals. The values of $\Theta_{l,m} \times \Phi_m$ for s-orbital ($l=0, m=0$), p-orbital ($l=1, m=0, \pm 1$), and d-orbitals ($l=2, m=0, \pm 1, \pm 2$) can be obtained and correlated with the shapes of orbitals.

For s-orbitals ($l=0, m=0$), the angular wave function $\Theta_{0,0} \times \Phi_0$ is independent of the angles θ and ϕ , i.e. there is no angular wave function and hence orbitals have only one orientation and are spherically symmetrical over all the directions, hence have spherical shape as well as are non-directional. Thus, s-orbitals are usually represented by circles. Greater the value of n and higher the number of nodal points for s-orbital, larger is the size of orbital. The electron density in s-orbitals could be shown by concentric shades as follows:

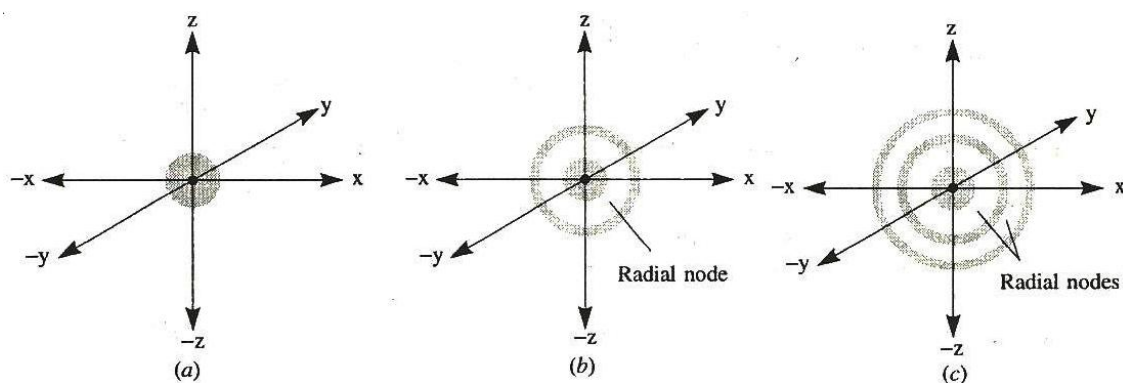

1s-orbital

2s-orbital

3s-orbital

(no nodal point)

(1 nodal point)

(2 nodal points)

Fig. 1.3 Electron charge density pictures for 1s, 2s and 3s-orbitals. Nucleus has been shown by thick dot.

For **p orbitals** ($l = 1, m = 0, \pm 1$), there are three values of m and therefore, there are three orientations of lobes of orbitals along cartesian coordinates viz. p_x, p_y and p_z . The subscripts x, y and z indicate the axes along which orbitals are oriented. The three p-orbitals are similar in size, shape and energy but differ in orientation only. The angular wave function for these orientations is the product $\Theta_{l,m} \times \Phi_m$. For $l=1, m=0$ orientation, the angular wave function $\Theta_{1,0} \Phi_0$ is a real quantity and corresponds to p_z orbital which is dumb-bell shaped curve along z -axis in three dimensional space (**Fig. 1.4 c**).

For $l = 1, m = +1$ and $l = 1, m = -1$ orientations, angular wave functions are $\Theta_{1,+1} \times \Phi_{+1}$ and $\Theta_{1,-1} \times \Phi_{-1}$ which have imaginary quantities and are avoided. The real values are obtained by the normalized linear combinations (addition and subtraction) of angular wave functions. Thus, addition process, i.e. $\Theta_{1,+1} \times \Phi_{+1} + \Theta_{1,-1} \times \Phi_{-1}$ gives normalised wave function corresponding to p_x orbital. In three dimensional space, this gives dumb-bell shaped curve along x - axis (Fig.1.4a) The subtraction process, i.e. $\Theta_{1,+1} \times \Phi_{+1} - \Theta_{1,-1} \times \Phi_{-1}$ gives normalised wave function corresponding to p_y orbital which is again dumb-bell shaped curve in three – dimensional space along y -axis (**Fig. 1.4b**).

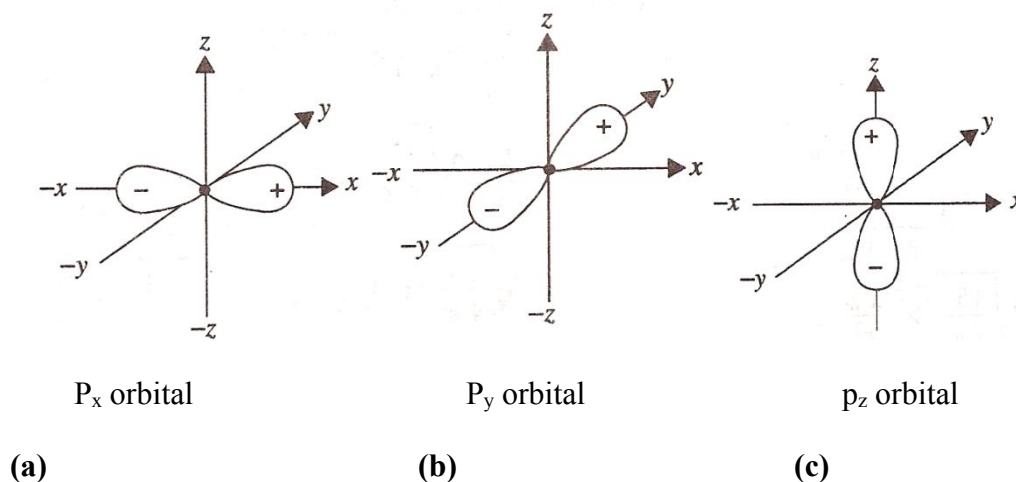

Fig.1.4 The orientation of p- orbitals along x, y and z- axis.

The (+) and (-) signs are algebraic signs of angular wave function and not the charge. The angular part of the wave function $\psi(\theta, \Phi)$ has (+) sign on one lobe and (-) sign on the opposite lobe although $\psi^2(\theta, \Phi)$ will be positive on both the lobes. Thus, for p-orbitals, the important points to be noted are:

- (i) Since x, y and z axes are perpendicular to each other, the three p-orbitals are also perpendicular to each other.
- (ii) Each of the three p-orbitals has two lobes on each side of the nucleus which is at the origin of the axes, hence the probability of finding the electron (s) in both lobes is equal. These lobes are separated by nodal planes passing through the nucleus. The electron density on the nodal plane is zero.
- (iii) Greater the value of n (principal quantum number or the shell number), larger is the size of p orbital i.e. 3p orbital is larger in size than 2p orbital though the shapes of both the orbitals are the same.
- (iv) The energy of the three p-orbitals with the same value of n is same i.e. all the three p-orbitals are degenerate.

For **d-orbitals** ($l = 2, m = 0, \pm 1, \pm 2$), five orientations (or orbitals) are there corresponding to five values of m for $l = 2$. Depending on the permitted combinations of l and m, values for five d-orbitals, angular wave functions corresponding to different d-orbitals are as follows:

For $l = 2$ and $m=0$, the angular wave function $\theta_{2,0} \times \Phi_0$ has a real value and corresponds to d_{z^2} -orbital. For $l = 2$ and $m = \pm 1$, we have two angular wave functions, $\theta_{2,+1} \times \Phi_{+1}$ and $\theta_{2,-1} \times \Phi_{-1}$. The values of these angular wave functions contain imaginary quantity and hence, these

values are not accepted. The real and acceptable values are obtained from these by normalized linear combinations (addition and subtraction) of above functions. The addition process of above angular wave functions, i.e. $\theta_{2,+1} \times \Phi_{+1} + \theta_{2,-1} \times \Phi_{-1}$ gives the wave function for d_{zx} (or d_{xz}) orbital and subtraction process, i.e. $\theta_{2,+1} \times \Phi_{+1} - \theta_{2,-1} \times \Phi_{-1}$, gives the wave function for dyz orbital, for $l = 2$ and $m = \pm 2$, we have two wave functions viz. $\theta_{2,+2} \times \Phi_{+2}$ and $\theta_{2,-2} \times \Phi_{-2}$. Again the values of these wave functions contain imaginary quantity and hence are not accepted. Real and acceptable values are obtained by the normalized linear combination of the two angular wave functions. The addition process of above angular wave functions, i.e., $\theta_{2,+2} \times \Phi_{+2} + \theta_{2,-2} \times \Phi_{-2}$, gives the wave function for $d_{x^2-y^2}$ orbital and subtraction process i.e., $\theta_{2,+2} \times \Phi_{+2} - \theta_{2,-2} \times \Phi_{-2}$, gives the wave subtraction for d_{xy} orbital. When these five angular wave functions for different orbitals obtained above are plotted in three dimensional space, we get the solid curves which give the orientations along the axes or in between the axes as shown below:

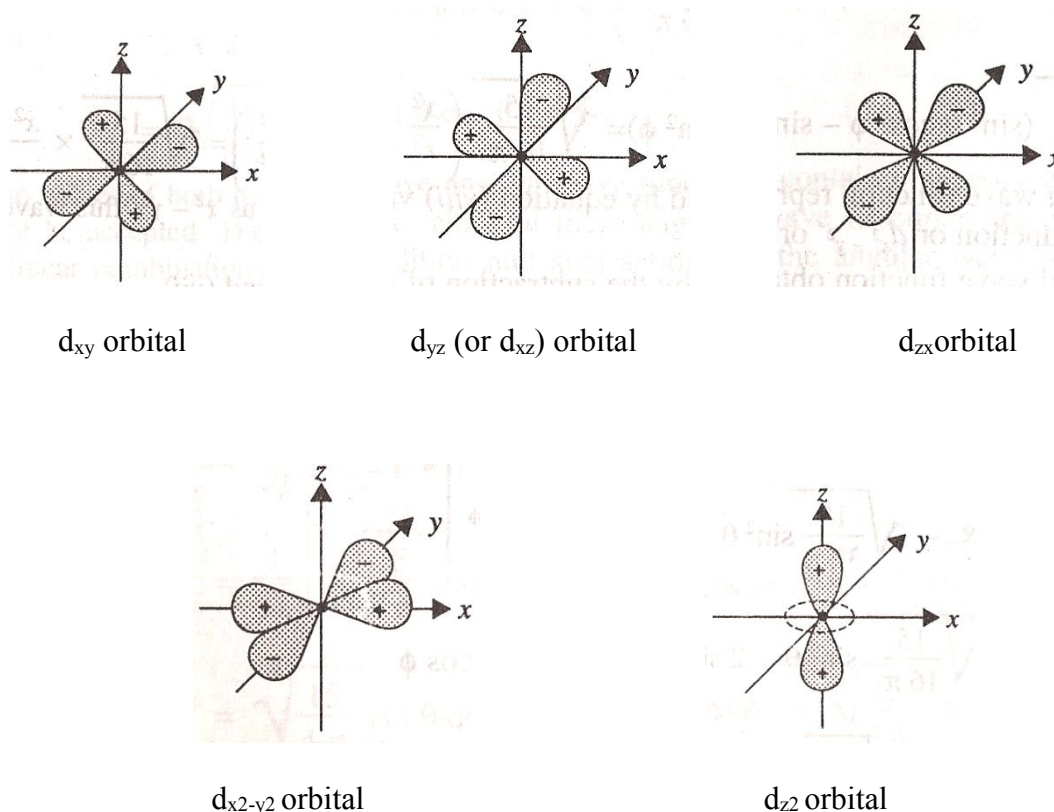

Fig. 1.5 Angular dependence and shapes of d-orbitals.

The probability density is the square of the wave function and is positive everywhere. The lobes on the positive or negative side of both the axes are assigned (+) sign and those on

positives side of one axis and negative side of the other or vice versa are assigned (-)sign. The characteristics of the d-orbitals may be summarized as follows:

- (i) d_{xy} , d_{yz} and d_{zx} (or d_{xz}) as well as $d_{x^2-y^2}$ orbitals are double dumb-bell shaped and contain four lobes. The lobes of the first three orbitals are concentrated between xy , yz and zx planes, respectively and lie between their coordinate axes. The lobes of $d_{x^2-y^2}$ orbital are concentrated along x and y axes. d_{z^2} orbital has a dumb-bell shape with two lobes along z -axis with (+) sign and a concentric collar or ring around the nucleus in xy plane with (-)sign.
- (ii) The d-orbitals belonging to same energy shell are degenerate, i.e. have the same energy in a free atom.
- (iii) The d-orbitals belonging to all main energy shells have similar shape but their size goes on increasing as the value of n and number of nodal points increase. For example, the size of 5d-orbital (number of nodal points = $5 - 2 - 1 = 2$) is larger than that of 4d-orbital (number of nodal points = $4 - 2 - 1 = 1$).

N.B. The shapes of f, g etc. orbitals are beyond the scope of the text.

1.7. QUANTUM NUMBERS

These are the integral numbers and most of them (i.e. first three) have been derived from the mathematical solution of Schrodinger's wave equation for ψ . These numbers serve as the address of the electrons in an atom and hence are also known as **identification numbers**. These describe the energy of an electron in a shell, radius of that shell (i.e. distance of electron from the nucleus), shape and orientation of the electron cloud (or orbital) and the direction of the spinning of the electron on its own axis.

There are four quantum numbers *viz.* principal quantum number (n), azimuthal or subsidiary quantum number (l), magnetic quantum number (m) and spin quantum number (s).

(i) Principal or Radial quantum number

This quantum number represents the number of shell or main energy level to which the electron belongs round the nucleus. It is denoted by the letter n . It arises from the solution of radial part of ψ . This quantum number can have integral values 1,2, 3, 4,.....etc. which are designated by the letters K,L,M,N,.....etc. as follows (proposed by Bohr):

Value of n	Designation
1	K

2	L
3	M
4	N

It can be concluded that the principal quantum number (n) gives an idea of:

- The shell or main energy level which the electron belongs to.
- The distance (r) of the electron from the nucleus, i.e. the radius of the shell.
- The energy associated with the electron.
- The maximum number of electrons that may be accommodated in a given shell.

According to Bohr-Berry scheme, the maximum number of electrons in n^{th} shell = $2n^2$. Thus the first shell ($n = 1$) can accommodate ($2 \times 1^2 = 2$) two electrons, second, third and fourth shells with $n = 2, 3$ and 4 can accommodate eight ($2 \times 2^2 = 8$), eighteen ($2 \times 3^2 = 18$) and thirty-two ($2 \times 4^2 = 32$) electrons, respectively.

(ii) Azimuthal or Subsidiary quantum number (l)

This quantum number is also known as orbital angular momentum quantum number. It is denoted by the letter l and refers to the subshell which the electron belongs to. This quantum number describes the motion of the electron and tells us about the shape of the orbitals of a subshell. The values of l depend on the value of n (the principal quantum number) and may have all possible values from 0 to (n-1), i.e. $l = 0, 1, 2, 3, \dots, (n-1)$. Thus, for a given value of n, total number of l values is equal to n, e.g. when $n = 4$, $l = 0, 1, 2, 3$ (total 4 values of l). For each value of l, separate notation is used which represents a particular subshell as shown below;

Azimuthal quantum number (l)	0	1	2	3	4
Notation for the sub-shell	s	p	d	f	g

These notations of subshells have been taken from the characteristics of the spectral lines in atomic spectra. Thus, s stands for sharp, p for principal, d for diffuse and f for fundamental.

The subshells belonging to various shells are given below:

N	L	Notation for the subshell
1	0	1s
2	0	2s

	1	2p
3	0	3s
	1	3p
	2	3d
4	0	4s
	1	4p
	2	4d
	3	4f

The main points to be noted for azimuthal quantum number are;

- This gives an idea of the subshell which the electron belongs to.
- Total number of subshells in a given shell is equal to the numerical value of n (main shell).
- This quantum number corresponds to the orbital angular momentum of the electron.
- This gives an idea of the shape of the orbitals of the subshell.
- The maximum number of electrons that can be accommodated in a given subshell is equal to $2(2l+1)$. Thus s , p , d and f - subshells with $l = 0, 1, 2$ and 3 can have a maximum of $2, 6, 10$ and 14 electrons, respectively, i.e. s^2, p^6, d^{10} and f^{14}

(iii) Magnetic quantum number (m)

This quantum number determines the direction of angular momentum of the electrons thereby describing the orientation of orbitals of a subshell in space. The value of m depends on the value of l thus showing that each subshell consists of one or more regions in space with maximum probability of finding the electron (i.e. orbitals). The number of such orbitals (or regions) is equal to the number of ways the electrons can orient themselves in space. This number is equal to $(2l + 1)$ and values of m are represented as $(+) l$ to $(-) l$ through 0 . Thus, each value of m represents a particular orbital within a subshell and total number of m values gives total number of orbitals in that subshell. For example, for s -subshell, $m = 0$ corresponding to $l=0$, i.e. m has only one value indicating that s -subshell has only one orbital or one possible orientation of electrons which is spherically symmetrical around the nucleus. When $l=1$, (i.e. p -subshell), m has three values *viz.* $+1, 0, -1$ implying that p -subshell has three

orbitals or orientations which are perpendicular to each other and point towards x, y, and z-axes. These are designated as p_x , p_y , and p_z . For $l = 2$ i.e. d-subshell, $m = +2, +1, 0, -1, -2$, i.e. five values meaning thereby that this subshell has five orbitals or orientations viz., d_{xy} , d_{yz} , d_{zx} , $d_{x^2-y^2}$ and d_{z^2} . On the same grounds it can be shown for f-subshell ($l=3$) that it has seven orbitals or orientations corresponding to seven values of m viz., $+3, +2, +1, 0, -1, -2$ and -3 . For p, d, and f subshells ($l=1, 2$ and 3) various m values may be summarized as follows:

Subshell	Value of l	Values of m	Total m values
p - subshell	1	+1, 0, -1	3
d - subshell	2	+2,+1,0,-1,-2.	5
f - subshell	3	+3,+2,+1,0,-1, -2, -3	7

The main point to be noted for magnetic quantum number is that it determines the total number of orbitals present in any subshell belonging to preferred orientations of electrons in space.

(iv) Spin quantum number (s)

This quantum number arises from the direction of spinning of electron about its own axis. It is denoted by the letter s which can have only two values shown as $(+)\frac{1}{2}$ and $(-)\frac{1}{2}$ representing clockwise spin (α -spin) or anticlockwise spin (β -spin). These values i.e. $(+)\frac{1}{2}$ and $(-)\frac{1}{2}$ are also represented as \uparrow (upward arrow) and \downarrow (downward arrow). Being a charged particle, a spinning electron generates a so called spin magnetic moment which can be oriented either up or downward. The value of s for an electron in an orbital does not affect the energy, shape, size or orientation of an orbital but shows only how the electrons are arranged in that orbital.

1.8. PAULI'S EXCLUSION PRINCIPLE

This principle was proposed by Pauli in 1924 and as an important rule, governs the quantum numbers allowed for an electron in an atom and determines the electronic

configuration of poly electron atoms. In a general form, this principal states that “**In an atom, any two electrons cannot have the same values of four quantum numbers**”. Alternatively, this can be put in the form “**any two electrons in an atom cannot exist in the same quantum state**”. Consequently, it can be said that any two electrons in an atom can have same values of any three quantum numbers but the fourth (may be n or l or m or s) will definitely have different values for them. This can be shown as follows;

Value of the all quantum number for any two electron in an atom

n	l	m	s
Same	Same	Same	Different
Same	Same	Different	Same
Same	Different	Same	Same
Different	Same	Same	Same

Thus the values of all the four quantum numbers for any two electrons residing in the same orbital like s, p_x, p_y, p_z, d_{xy} etc. cannot be the same. For example, in case of 2 electrons in 1s-orbital (i.e. 1s²), the values of n, l and m are same for both the electrons but s has different values as shown below:

	n	l	m	s
1 st electron	1	0	0	$+\frac{1}{2}$
2 nd electron	1	0	0	$-\frac{1}{2}$

For 1s² electrons

The values of s may also be written in the reverse order but by convention the given order is preferred. The important conclusion drawn from this discussion is that “**an orbital can accommodate only two electrons with opposite spins**”

● **Application of Pauli’s Exclusion Principle**

This principle has been used to calculate the maximum number of electrons that can be accommodated in an orbital, a subshell and in a main shell. For example, for K-shell, n=1,

$l=0$ and $m=0$ and s can have a value equal to either $(+)\frac{1}{2}$ or $(-)\frac{1}{2}$. These values of n , l , m and s give two sets of values of four quantum numbers as gives above. It is concluded that in K-shell, there shall be only one subshell with one orbital i.e. the s-orbital is present which can contain only two electrons with $s = (+)\frac{1}{2}$ and $(-)\frac{1}{2}$.

For L-shell, $n=2$, $l=0$ and 1 . The corresponding values of m are 0 (for $l=0$) and $+1, 0, -1$ (for $l=1$). For each value of m , s will have two values, $(+)\frac{1}{2}$ and $(-)\frac{1}{2}$. This leads to eight sets of quantum numbers belonging to eight different electrons. These are shown below:

$n = 2, l = 0, m = 0, s = +\frac{1}{2}$	}	These values correspond to two electrons in 2s – orbital.
$n = 2, l = 0, m = 0, s = -\frac{1}{2}$		

$n = 2, l = 1, m = +1, s = +\frac{1}{2}$	}	These values correspond to two electrons in $2p_x$ – orbital.
$n = 2, l = 1, m = +1, s = -\frac{1}{2}$		

$n = 2, l = 1, m = 0, s = +\frac{1}{2}$	}	These values correspond to two electrons in $2p_y$ – orbital.
$n = 2, l = 1, m = 0, s = -\frac{1}{2}$		

$n = 2, l = 1, m = -1, s = +\frac{1}{2}$	}	These values correspond to two electrons in $2p_z$ – orbital.
$n = 2, l = 1, m = -1, s = -\frac{1}{2}$		

By convention, the first p-orbital is denoted as p_x , second as p_y and third as p_z -orbital as given above. Therefore, we can say that an orbital can accommodate maximum two electrons. Further, since same values of l for a particular value of n corresponds to a particular subshell, total number of electrons in a subshell can be calculated, e.g., s-subshell contains two and p-subshell ($l=1$) will accommodate six electrons, respectively. Thus total number of electrons in L-shell will be eight (2 in s and 6 in p-subshell). Likewise, one can calculate total number of electrons in M-shell (18) and N-shell (32) etc. as well as d (10) and f (14) subshells.

1.9. HUND'S RULE OF MAXIMUM MULTIPLICITY

This rule states that “**electron pairing in the orbitals of a subshell will not take place until each orbital is filled with single electron**” (due to same energy of orbitals of a subshell). This is because it is easier for an electron to enter an empty orbital than an orbital which already possesses an electron.

If an atom has three electrons in p-subshell, these can be arranged in three p-orbitals as follows:

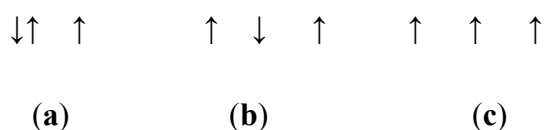

Among these arrangements, the option(c) is the correct arrangement because this rule can be stated alternatively as “**the most stable arrangement of electrons in the orbitals of a subshell is that with greatest number of parallel spins**”. It implies that before pairing starts, all the electrons of the subshell have the same spins (parallel).

This rule serves as a guideline for filling of multi orbital p, d and f subshells, e.g., the electron pairing in p, d and f-subshells will not start until each orbital of the given subshell contains one electron. Thus pairing starts in the three orbitals of p-subshell at fourth electron, in five orbitals of d-subshell at sixth electron and in seven orbitals of f-subshell at eighth electron, respectively. The electronic arrangements (or configurations) for p^4 , d^6 and f^8 systems have been illustrated here along with p^3 , d^5 and f^7 :



Here p^3 , d^5 and f^7 provide the examples of maximum multiplicity in the respective subshells and p^4 , d^6 and f^8 provide the examples where pairing of electrons in these subshells starts.

1.10. THE AUFBAU PRINCIPLE

Aufbau is a German word which means building up or construction. The building up of orbitals implies the filling of orbitals with electrons. This principle gives us the sequence in which various orbitals are filled with electrons. The principle can be stated as “**in the ground state of poly electronic atoms, the electrons are filled in various subshells in the increasing order of their energy**”. This means the electrons are filled in the subshell of the lowest energy first followed by the higher energy subshells.

There are certain rules which constitute the Aufbau principle:

- (i) In general, the subshells with lower n values are filled first followed by those with higher n -values (called lower n rule).
- (ii) For any given principal quantum number n , the order of filling up of subshells is s , p , d and f .
- (iii) $(n + 1)$ Rule; sometime lower $(n + 1)$ rule is violated. In such cases $(n+1)$ rule is applicable according to which the subshells are filled in order of increasing $(n+1)$ values, e.g., $4s$ - subshell [$(n+1) = 4+0$ equal to 4] is filled before $3d$ subshell [$(n+1) = 3+ 2$ equal to 5] due to lower $(n+1)$ values. Keeping in mind the above discussion, various subshells can be arranged in the order of increasing energy as follows:

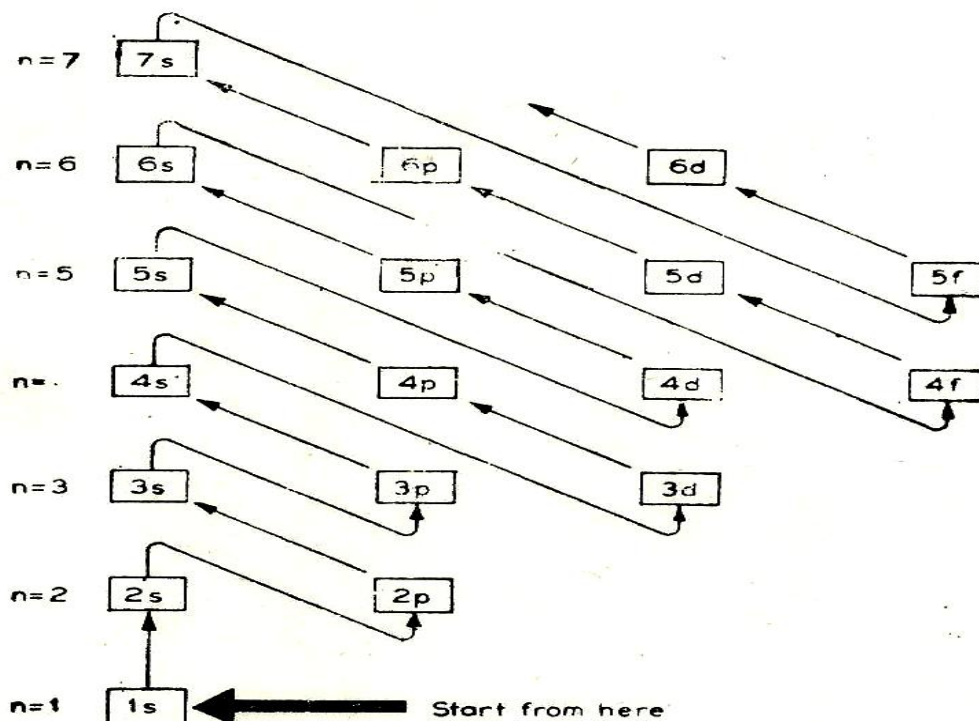

Energy sequence of subshells for electron filling

This relative order of energy of various subshells of an atom may also be given as follows:

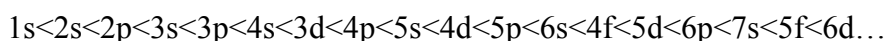

The electrons are filled according to this order only in polyelectron atoms. Configurations of lanthanum (La, $Z = 57$) and actinium (Ac, $Z = 89$) are the exceptions where the last electron enters 5d and 6d-subshells instead of 4f and 5f-subshells against the Aufbau's lower ($n + 1$) rule though $(n+1)$ values are same for 4f and 5d as well as 5f and 6d-subshells.

1.11. ELECTRONIC CONFIGURATION OF ELEMENTS

Based on the Pauli's exclusion principle, Hund's maximum multiplicity rule and Aufbau principle, we can formulate a system for electron distribution in atoms and electronic configuration of the elements can be worked out. By electron distribution, we mean arrangement of electrons in various atomic orbitals and subshells.

Looking at the relative energy sequence of subshells of atoms in the elements, it can be concluded that we can work out and write down the electronic configuration of the elements straightaway up to argon (Ar, $Z = 18$) as follows:

Name of the element	Symbol with atomic number	Electronic configuration
Hydrogen	H ($Z = 1$)	$1s^1$
Helium	He ($Z = 2$)	$1s^2$
Lithium	Li ($Z = 3$)	[He] $2s^1$
Beryllium	Be ($Z = 4$)	[He] $2s^2$
Boron	B ($Z = 5$)	[He] $2s^2 2p^1$
Carbon	C ($Z = 6$)	[He] $2s^2 2p^2$
Nitrogen	N ($Z = 7$)	[He] $2s^2 2p^3$
Oxygen	O ($Z = 8$)	[He] $2s^2 2p^4$
Fluorine	F ($Z = 9$)	[He] $2s^2 2p^5$
Neon	Ne ($Z = 10$)	[He] $2s^2 2p^6$
Sodium (Natrium)	Na ($Z = 11$)	[Ne] $3s^1$
Magnesium	Mg ($Z = 12$)	[Ne] $3s^2$

Aluminium	Al (Z = 13)	[Ne] 3s ² 3p ¹
Silicon	Si (Z = 14)	[Ne] 3s ² 3p ²
Phosphorus	P (Z = 15)	[Ne] 3s ² 3p ³
Sulphur	S (Z = 16)	[Ne] 3s ² 3p ⁴
Chlorine	Cl (Z = 17)	[Ne] 3s ² 3p ⁵
Argon	Ar (Z = 18)	[Ne] 3s ² 3p ⁶

If we try to write down the electronic configuration of potassium (Kalium) (K, Z=19) according to above trend, the last electron must go to the 3d subshell, i.e. $K_{19} = [Ne] 3s^2 3p^6 3d^1$ or $[Ar] 3d^1$, but this electron is said to enter the 4s-subshell according to lower(n+1)rule of Aufbau principle. This may also be explained on the basis of effective nuclear charge given at the end of this topic. The (n + 1) value for 4s = 4+0 is equal to 4 and for 3d, it is 3+2 is equal to 5. Hence the electronic configuration of potassium (K, Z = 19) is $[Ar_{18}] 4s^1$ and that for calcium (Ca, Z = 20), the next higher element, is $[Ar] 4s^2$. Again, the last electron in the atom of the next element, Sc, (Z = 21) has the opportunity to occupy either 3d or 4p-subshell because both are available to it. The (n+1) values for 3d (3+2=5) and 4p (4+1 = 5) are same and electron prefers to enter that subshell which has lower n value, i.e. 3d-subshell according to lower n rule of Aufbau principle. The filling of 3d-subshell goes on up to zinc (Z = 30).

The electronic configurations of the elements with Z = 21 to 30 are given below:

Name	Symbol with atomic number	Electronic Configuration
Scandium	Sc (Z = 21)	$[Ar] 4s^2 3d^1$
Titanium	Ti (Z = 22)	$[Ar] 4s^2 3d^2$
Vanadium	V (Z = 23)	$[Ar] 4s^2 3d^3$
Chromium	Cr (Z = 24)	$[Ar] 4s^1 3d^5$
Manganese	Mn (Z = 25)	$[Ar] 4s^2 3d^5$
Iron	Fe (Z = 26)	$[Ar] 4s^2 3d^6$
Cobalt	Co (Z = 27)	$[Ar] 4s^2 3d^7$
Nickel	Ni (Z = 28)	$[Ar] 4s^2 3d^8$
Copper	Cu (Z = 29)	$[Ar] 4s^2 3d^{10}$

Zinc Zn (Z = 30) [Ar] 4s²3d¹⁰

The next six elements, viz. Ga₃₁, to Kr₃₆ belong to p-block and the last electron, as is evident, enters the 4p – subshell of the atoms of these elements. The electronic configurations of these elements are as follows:

Gallium	Ga (Z = 31)	[Ar] 4s ² 3d ¹⁰ 4p ¹
Germanium	Ge (Z = 32)	[Ar] 4s ² 3d ¹⁰ 4p ²
Arsenic	As (Z = 33)	[Ar] 4s ² 3d ¹⁰ 4p ³
Selenium	Se (Z = 34)	[Ar] 4s ² 3d ¹⁰ 4p ⁴
Bromine	Br (Z = 35)	[Ar] 4s ² 3d ¹⁰ 4p ⁵
Krypton	Kr (Z = 36)	[Ar] 3d ¹⁰ 4s ² 4p ⁶

In next two elements of 5th period, the last electron goes to 5s- subshell. (s-block):

Rubidium	Rb (Z = 37)	[Kr] 5s ¹
Strontium	Sr (Z = 38)	[Kr] 5s ²

Filling of 4d – subshell begins in the next element, yttrium, Y (Z = 39) and ends at cadmium, Cd (Z = 48) {Y: [Kr] 5s² 4d¹ to Cd: [Kr] 5s² 4d¹⁰} with anomalies in the configurations of ⁴²Mo, ⁴⁶Pd and ⁴⁷Ag as shown below. In the next six elements of p-block, electron filling occurs in 5p – subshell, i.e. Indium ⁴⁹In: [Kr] 5s² 4d¹⁰5p¹ to Xenon, ⁵⁴Xe : [Kr] 5s² 4d¹⁰ 5p⁶ or 1s² 2s² 2p⁶ 3s² 3p⁶3d¹⁰4s² 4p⁶ 4d¹⁰ 5s²5p⁶. Next two elements caesium ⁵⁵Cs and barium, ⁵⁶Ba are s-block elements and the last electron in these elements enters the 6s-subshell. ⁵⁵Cs: [Xe] 6s¹ and ⁵⁶Ba: [Xe] 6s². Next element lanthanum ⁵⁷La, belongs to d-block: [Xe] 6s² 5d¹ and is followed by 14 lanthanides: cerium, ⁵⁸Ce to lutetium, ⁷¹Lu in which electron filling takes place in f-subshell except ⁶⁴Gd and ⁷²Lu in which the last electron enters d-subshell due to f⁷ and f¹⁴ stable configuration but these show close resemblance with other f-block elements and have been placed with them in the periodic table.

It is observed that in case of chromium (Cr, Z = 24) and copper (Cu, Z = 29), the electronic configurations are against the trend. These configurations have been obtained experimentally by spectroscopic studies. Simple explanation to these anomalies can be given as under. For Cr and Cu, d-electrons being higher in number contribute more towards the stability of the atoms. Because d⁵ (just half filled) and d¹⁰ (completely filled) configurations

are more stable compared to d^4 and d^9 configurations, electronic transition occurs from s to d-subshells in these elements (due to exchange energy effect and symmetry of orbitals), i.e. Cr: $4s^2 3d^4 \rightarrow 4s^1 3d^5$ and Cu : $4s^2 3d^9 \rightarrow 4s^1 3d^{10}$. s- electrons being less in number have little effect in this pursuit.

Similar anomalies have also been observed in the higher homologues of these elements, viz. ,molybdenum (Mo, $Z = 42$) : $[\text{Kr}] 5s^1 4d^5$ and silver (Ag, $Z = 47$) : $[\text{Kr}] 5s^1 4d^{10}$. Palladium (Pd, $Z = 46$) contains another typical configuration: $[\text{Kr}] 5s^0 4d^{10}$. Also there are anomalies in the configurations of lanthanides and actinides.

The important point to be noted here is that during the filling of electrons, these enter first in ns-subshell and then (n-1) d or (n-2) f-subshell. But during the removal of electron (s), it is first removed from n^{th} s orbital rather than (n-1) d or (n-2) f-subshell though $E_{ns} < E_{n-1d} < E_{n-2f}$ and removal of the electron must occur from higher energy subshell. For example, in case of first transition series (3d-series) elements filling and removal of 4-s-electrons occurs first followed by 3d-electrons. This is, perhaps, because after filling of d-subshell, it becomes of lower energy than 4s-subshell.

1.12. EFFECTIVE NUCLEAR CHARGE ($Z_{\text{EFF.}}$)

This term is related with shielding or screening effect. The electrons residing in the innermost shell experience the attraction of full charge of the nucleus (actual charge) but this is not true for the electrons contained in the outer shells. Actually the electrons in the inner shells called intervening electrons, act as a shield or screen between the nucleus and outer shell electrons and thus reduce the force of attraction between them. This is called screening or shielding effect. This effect of inner electrons causes a decrease in the actual charge of the nucleus (atomic number, Z) acting on the outer electrons by a quantity σ (sigma) known as screening or shielding constant. The decreased nuclear charge ($Z - \sigma$) is called effective nuclear charge denoted by Z_{eff} .

It is to be noted that only inner electrons cause the shielding of nucleus from outer electrons and outer electrons do not produce any shielding effect on any of the inner electrons in question.

The shielding constant is greater than zero and less than Z_{actual} and is a measure of the degree to which the intervening electrons shield the outer shell electrons from the nuclear pull.

The effective nuclear charge (Z_{eff}) is defined as “**the difference between actual nuclear charge (Z_{actual}) and the screening constant (σ) produced by the intervening electrons**”.

The shielding effect caused by inner electrons varies with the type of subshells to which these electrons belong, e.g. $s > p > d > f$. This shows that s-electrons cause maximum shielding effect followed by p, d and f-electrons which produce minimum shielding effect due to their arrangement around nucleus. There are certain factors which influence the magnitude of σ and Z_{eff} .

- (i) Number of intervening electrons: Greater is the number of intervening electrons, more will be the magnitude of σ and less is the value of Z_{eff} . Down in a group, number of intervening electrons in elements increases and hence value of σ also increases. Consequently, Z_{eff} value goes on decreasing.
- (ii) Size of atom: As the size of atoms increases, value of Z_{eff} decreases, e.g. down in a group. Along a period, atomic size decreases and hence Z_{eff} goes on increasing.

Slater's Rules for calculating σ and Z_{eff} .

Slater gave illustrative rules for calculating σ and Z_{eff} . These have been discussed here with illustrations:

- (i) The screening constant (σ) for an electron contained in ns or any of np orbitals of n^{th} shell of an atom/ion = $0.35 \times [\text{number of remaining electrons in } n^{\text{th}} \text{ shell}] + 0.85 \times [\text{number of electrons in } (n-1)^{\text{th}} \text{ shell}] + 1.0 \times [\text{number of electrons in farther inner shells}]$.

From this formula, we conclude that;

- (a) Each of the remaining electrons in the n^{th} shell contributes 0.35 to the value of σ .
- (b) Each of the electrons in $(n-1)^{\text{th}}$ shell makes a contribution of 0.85 to the value of σ .
- (c) Each of the electrons in the next inner shells makes a contribution of 1.0 to it.
- (d) There is no contribution of electrons to the value of σ which are residing in the orbitals having higher value of the principal quantum number than the shell number of the electron in question.
- (e) For an s-electron of first shell ($n=1$), there will be a contribution of 0.30 from other single electron in 1s-orbital.

Some examples may be cited to make the rule clear:

Example 1. Calculate σ and Z_{eff} values for 4s electron in

- (i) Cu ($Z = 29$) and (ii) Mn ($Z = 25$) atom.

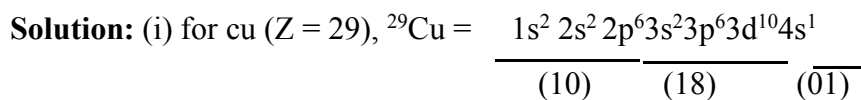

σ for $4s^1$ electron in Cu atom = $0.35 \times 0 + 0.85 \times 18 + 1.0 \times 10 = 25.30$

$\therefore Z_{\text{eff}}$ for $4s^1$ electron in Cu atom = $Z_{\text{act.}} - \sigma = 29 - 25.30 = 3.70$

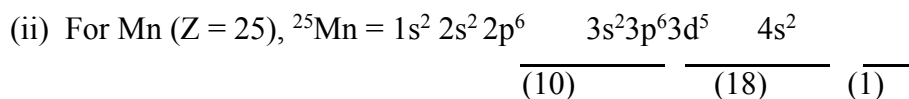

σ for $4s^1$ electron in Mn-atom = $0.35 \times 1 + 85 \times 13 + 1.0 \times 10 = 21.40$

$\therefore Z_{\text{eff}}$ experienced by a $4s -$ electron in Mn atom = $Z_{\text{act.}} - \sigma = 25 - 21.40 = 3.60$

Example 2. Calculate Z_{eff} for (i) the last electron in Cl atom ($Z=17$) and

(ii) $1s$ electron in N atom ($Z = 7$).

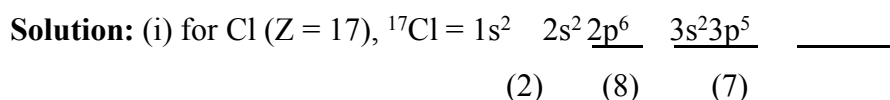

\therefore Last shell contains 7 electrons, hence remaining electrons in this shell for the last electron = $7 - 1 = 6$

σ for the last electron of Cl-atom = $0.35 \times 6 + 0.85 \times 8 + 1.0 \times 2 = 10.90$

$\therefore Z_{\text{eff}}$ for the last electron of Cl atom = $17 - 10.90 = 6.10$

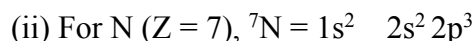

(2) (5)

There will be no contribution of valence shell electrons towards σ of $1s^1$ electron.

$\therefore \sigma$ of $1s^1$ electron of N atom = $0 \times 5 + 0.30 \times 1 = 0.30$

and Z_{eff} for this electron = $Z_{\text{act.}} - \sigma = 6.70$

(ii) σ for an electron contained in $(n-1)$ d-orbitals of $(n-1)^{\text{th}}$ shell of an atom/ion = $0.35 \times [\text{number of electrons in } (n-1)\text{d-orbitals}] + 1.0 \times [\text{Number of electrons in } (n-1)\text{s}, (n-1)\text{p-orbitals and inner shells}]$

From this formula, it is inferred that

- (a) There is no contribution of the electrons of ns-orbital to the value of σ .
- (b) Each of the remaining electrons in the $(n-1)$ d-orbitals contributes 0.35 to σ .

(c) Each of the electrons in (n-1) s and (n-1)p-orbitals as well as inner shells i.e. n=1 to n (n-2)th shell makes a contribution of 1.0 to the value of σ .

Let us discuss few examples:

Examples 3. Calculate σ and Z_{eff} for 3d-electron in (i) Cr (Z = 24) and (ii) Ni (Z = 28).

Solution. (i) for Cr (Z = 24), $^{24}\text{Cr} = \frac{1s^2 2s^2 2p^6 3s^2 3p^6}{(18)} \frac{3d^5}{(5)} \frac{4s^1}{(1)}$

(on arranging the configuration according to Slater's rule)

Here $4s^1$ electron does not contribute towards the value of σ .

σ for a 3d-electron in Cr atom = $0.35 \times 4 + 1.0 \times 18 = 19.40$

(remaining electrons in 3d orbitals = $5 - 1 = 4$)

$\therefore Z_{\text{eff}}$ experienced by a 3d electron in Cr atom = $Z_{\text{act.}} - \sigma = 24 - 19.40 = 4.60$

(ii) For Ni (Z = 28), $^{28}\text{Ni} = \frac{1s^2 2s^2 2p^6 3s^2 3p^6}{(18)} \frac{3d^8}{(8)} \frac{4s^2}{(2)}$

$4s^2$ electrons do not contribute to the value of σ . Remaining electrons in 3d orbitals = $8 - 1 = 7$.

σ for a 3d-electron in Ni atom = $0.35 \times 7 + 1.0 \times 18 = 20.45$

$\therefore Z_{\text{eff}}$ for a 3d-electron in this atom = $Z - \sigma = 28 - 20.45 = 7.55$

(iii) To calculate the Z_{eff} experienced at the periphery of an atom/ion.

This is calculated by subtracting the shielding constant (σ) for all the electrons present in the electronic configuration of the atom/ion from its actual nuclear charge.

For example, suppose we have to calculate the Z_{eff} at the periphery of Ti (Z = 22) atom,

then $^{22}\text{Ti} = \frac{1s^2 2s^2 2p^6}{(10)} \frac{3s^2 3p^6 3d^2}{(10)} \frac{4s^2}{(2)}$

σ for all the electrons of Ti atom = $0.35 \times 2 + 0.85 \times 10 + 1.0 + 10 = 19.20$

$\therefore Z_{\text{eff}}$ at the periphery of this atom = $Z_{\text{act.}} - \sigma = 22 - 19.20 = 2.80$

Applications of effective nuclear charge and Slater's Rules

The concept of effective nuclear charge in the light of Slater's rule has been used to explain; why is 4s-orbital filled in preference to 3d-orbitals in potassium atom ($Z=19$)?

Argon ($Z = 18$) with electronic configuration: $1s^2 2s^2 2p^6 3s^2 3p^6$, is the last element of third period in which the 3d-orbitals remain vacant and the last electron goes to 3p-subshell. For the 19th electron of potassium atom, two sub shells are theoretically available, viz. 3d and 4s. Under these two possibilities, the electronic configurations of potassium atom are:

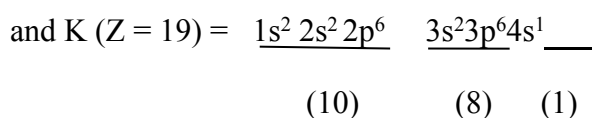
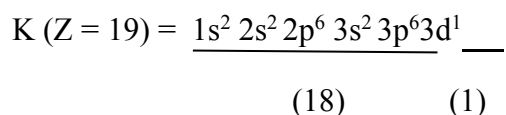

The σ (shielding constant) for 4s-electron of K atom

$$= 0.35 \times 0 + 0.85 \times 8 + 1.0 \times 10 = 16.80$$

$$\therefore Z_{\text{eff}} \text{ for } 4s^1 \text{ electron of K atom} = Z_{\text{act}} - \sigma = 19 - 16.80 = 2.20$$

Similarly, the Z_{eff} experienced by 3d¹ electron of K-atom is = $19 - [0.35 \times 0 + 1.0 \times 18] = 1.0$

Since Z_{eff} for 4s¹ electron is greater than 3d¹ electron of K atom, the attractive force between 4s¹ electron and nuclear charge is greater than that of between 3d¹ electron and the nucleus of this atom. Hence the configuration, $1s^2 2s^2 2p^6 3s^2 3p^6 4s^1$, would be more stable than that having 3d¹ electron. This infers that 4s-orbital is filled in preference to 3d-orbitals in K atom. Other applications of the concept will be given in the next units of the text as and when required.

1.13. SUMMARY

The summary of the this unit is :

- This unit contains the text related with the dual nature of matter, the uncertainty principle, probability concept, the wave equation, significance of ψ and ψ^2 and related wave functions as well as probability distribution curves and shapes of atomic orbitals in the simple way.

- A brief and informative discussion of quantum numbers, the rules governing the filling of atomic orbitals such as Pauli's exclusion principle, Hund's rule and Aufbau principle has been given.
- The electronic configuration of elements has effectively been discussed with examples and the limitations are also given. A
- At the last, Slater's rules for calculating the effective nuclear charge with examples and applications have been given briefly.

1.14. TERMINAL QUESTIONS

- i) What do you mean by dual nature of matter?
- ii) Discuss the meaning and significance of ψ and ψ^2 with reference to the wave equation.
- iii) Write a note on radial wave function.
- iv) Discuss the angular wave function and correlation between this wave function and shape of p-orbitals.
- v) Discuss azimuthal quantum number with suitable examples.
- vi) What possible values of n, l, m and s quantum numbers can an electron in a 4f- orbital have?
- vii) How many electrons can be contained in fourth shell of an atom and why?
- viii) How are the quantum numbers n, l and m related to one another?
- ix) What is meant by shielding effect?
- x) What quantum numbers would you assign to the last electron of Rb-atom ($Z = 37$) as well as its 30th electron?
- xi) Calculate σ and Z_{eff} for 3d electron in Mn ($Z = 25$) atom.
- xii) Write down the electronic configurations of the elements with $Z = 46$, and 71.

1.15 REFERENCE

1. Principles of Inorganic Chemistry: B. R. Puri, L.R. Sharma & K. C. Kalia, Milestone Publishers and Distributors, Daryaganj, Delhi (2013).
2. Selected topics in Inorganic Chemistry: W.U. Malik, G.D. Tuli & R.D. Madan, S. Chand & Co. Ltd., New Delhi (1993).

3. Comprehensive Inorganic Chemistry: Sulekh Chandra, New Age International (Pvt.) Ltd., New Delhi (2004).
4. The Nature of the Chemical Bond: Linus Pauling, 3rd Edn., Cornell University Press, New York (1960).
5. A Simple Guide to Modern Valency Theory: G.I. Brown, Revised Edn., Longmans Green, London (1967).
6. Advanced Inorganic Chemistry: Satya Prakash, G.D. Tuli, S.K. Basu and R.d. Madan, Vol. I, 7th Edn., S. Chand & Co. Ltd, New Delhi (1998).
7. Shriver and Atkins' Inorganic Chemistry: Peter Atkins *et. al.*, 5th Edn., Oxford University Press, New York (2010).

UNIT:2 THE PERIODIC TABLE

CONTENTS:

- 2.1 Objectives
- 2.2 Introduction
- 2.3 History of Periodic Table
- 2.4 Laws of Periodic Table
- 2.5 Summary
- 2.6 Terminal Question
- 2.7 Answers
- 2.8 References

2.1 INTRODUCTION

In the chapter first we discuss the atomic structure and various parameters the arrangement of the filling electrons in their respective orbitals. The atomic structure refers to the structure of an atom comprising a nucleus (centre) in which the protons (positively charged) and neutrons (neutral) are present. The negatively charged particles called electrons revolve around the centre of the nucleus. Now in this section we discuss about the periodic classification and the modern periodic table according to the Moseley classification.

With the rapid advance of chemistry with time, the number of discovered elements increased continuously. These elements exhibited marked difference in their properties. Hence it became more and more difficult and tedious job for the scientists to study each and every element individually for its physical and chemical behaviour. Therefore, many attempts were made to arrange the elements with similar physical and chemical behaviour, at one place to make their study systematic and easier. This attempt was named **the periodic classification of elements** which means, the ideal arrangement of those elements which are alike in their behavior. It was thought, in the process, that there might be some relation between some fundamental characteristic of an element and its properties. Originally, this characteristic taken into account was the atomic weight, later called atomic mass. Eventually, the atomic mass was replaced by more appropriate basis, the atomic number. At the same time the periodicity in properties of the elements was also taken care of.

2.2 OBJECTIVE

In the present chapter you will be able to the :

- An information about how the elements whose number increased with time, were organized in the tabular form.
- In this unit you will about the history of periodic table and laws of periodic table
- The systematic classification of these elements with respect to their physical/chemical properties made the readers and the scientists comfortable and predictable in their further study.

- Till date, this number has gone up to 118 to whom symbols have been assigned and some more elements have been predicted and evidenced by laboratory studies.

2.2 HISTORY OF PERIODIC TABLE

The first important attempt for the arrangement of elements, i.e. their classification, was made by Dobereiner in the beginning of nineteenth century by proposing what is now known as “**Dobereiner’s law of triads**”. According to him when various triads (i.e. containing three) of elements with similar properties were arranged in increasing order of their atomic weights, the atomic weight of the middle element of the triad was found approximately equal to the arithmetic mean of the remaining two corner elements. For example:

Li	Na	K
7	23	39
S	Se	Te
32	79	127.6
Cl	Br	I
35.5	80	127

This law of triads was not found useful because triads of all the known elements at that time could not be formed.

In the middle of nineteenth century, scientist **Duma** put forward his idea called “**Duma’s homologous series**” in an attempt to classify the elements. He proposed that “the atomic weights of certain elements could be placed in homologous series like organic compounds”. For example, the elements of nitrogen family were arranged as follows:

Element	Atomic Weight	Homologous series
N	14	A
P	31 (14+17)	A+B
As	75 (14+17+44)	A+B+C
Sb	119 (14+17+2x44)	A+B+2C
Bi	207 (14+17+4x44)	A+B+4C

(Here A = 14, B = 17 and C = 44).

This scheme of Duma was also not found useful in the classification of elements.

Further step in this field was taken in 1864 by John Newlands, an English chemist. He tried to correlate the chemical properties of elements with their atomic weights and proposed a law, now known as “**Newlands’ law of octaves**”. According to this law “**if the elements were arranged in increasing order of their atomic weights, every eighth element was found to have similar properties**”. For example, as given below, the eighth element starting from Li is Na which have similar properties. Similarly, Mg is the eighth element from Be and both of them also have similar properties.

Li	Be	B	C	N	O	F
7	9	11	12	14	16	19
Na	Mg	Al	Si	P	S	Cl
23	24	27	28	31	32	35.5

However, this classification proposed by Newlands was limited to 14 elements only (given above) and his work was not accepted by scientific community.

2.3 LAWS OF PERIODIC TABLE

(A) Mendeleev’s Periodic law:

Dmitri Mendeleev, a Russian chemist, in 1869 observed that “**when the elements were arranged in the increasing order of their atomic weights, the elements with similar properties recurred (or reappeared) at regular intervals (or periods)**”. From this observation, he put forward a law known as Mendeleev’s periodic law. This law states:

“The physical and chemical properties of elements are periodic functions of their atomic weights”.

Table 2.1: Mendeleeff's Original Periodic Table.

Group Row	Group I	Group II	Group III	Group IV	Group V	Group VI	Group VII	Group VIII
H=1								
Li=7	Be=9A	B=11	C=12	N=14	O=16	F=19		
Na=23	Mg=24	Al=27.3	Si=28	P=31	S=32	Cl=35.5		
K=39	Ca=40		?=44	Ti=48	V=51	Cr=52	Mn=55	Fe=56 Co=59 Ni=59
Cu=63	Zn=65	?=68	?=72	As=75	Se=79	Br=80		
Rb=85	Sr=87	Yt=88	Zr=90	Nb=94		Mo=96	?=100	Ru=104 Rh=104 Pd=106
Ag=108	Cd=112	In=113	Sn=118		Sb=122	Te=127.6	I=127	
Cs=133	Ba=137		Di=138	Ce=140				
			Er=178	Hf=180	Ta=182	W=184		Cs=195 Ir=197 Pt=198
Au=199	Hg=200	Tl=204	Pb=207	Bi=209				
				Th=231		U=240		

Working on this law, he arranged the elements, known at his time, in the increasing order of atomic weights and presented them in the form of a table. That was known as **Mendeleev's periodic table** (please see table 2.1).

Table 2.1: Mendeleev's original Periodic Table

In that table, the elements were arranged in columns (called groups) and rows (called periods). The original periodic table formed by Mendeleev had following characteristics:

- The elements were arranged in the increasing order of their atomic weights.
- The table contained eight vertical columns and seven horizontal rows.
- Every column (group) contained two sub groups (subgroup A and subgroup B) except, the eighth column which contained three series of three elements (triads).
- The columns contained the elements of similar physical and chemical properties.
- First period (horizontal row) was called very short period, second and third periods were named as short periods, fourth and fifth periods were called long periods and sixth period was named very long period. Seventh period contained only a few elements (and is still incomplete). The elements of 2nd and 3rd periods were called the typical elements by Mendeleev because, these were truly the representatives of their respective groups.
- Mendeleev had left empty spaces for elements unknown at his time, e.g. Sc, Ga,

Ge etc. but had predicted their properties. At his time, around 65 elements were known.

Merits of Mendeleev's Periodic Table:

- (i) It helped in the study of elements and compounds which has become easy and systematic.
- (ii) The empty spaces in the Mendeleev's periodic table encouraged the scientists to work in the field of discovery of new elements since he had predicted the properties of the probable elements.

Defects of the Mendeleev's Periodic Table:

Although Mendeleev's periodic table helped a lot to study the properties of elements and correlate the elements with one another, yet there were some anomalies which existed unanswered in the Mendeleev's table. These were:

- (i) The position of hydrogen remained inappropriate because some of its properties resembled with alkali metals and some others with halogens. Hence it might be placed in group I or group VII.
- (ii) Dissimilar elements of sub groups were placed together in groups, i.e. alkali metals and coinage metals of 1st group have altogether different properties. Similar is the case with halogens and elements of manganese family in group VII (sub group A and B elements).
- (iii) Certain elements with higher atomic weights were placed before those with lower atomic weights, e.g.

Cobalt	Nickel (elements of group VIII, triad I)
58.93	58.69

Tellurium	Iodine (elements of group VI and VII)
127.60	126.90

- (iv) The Table did not show any correlation between chemical properties and electronic configuration of elements.
- (v) No information regarding the position of isotopes and isobars was available from the table.

Modified form of Mendeleev's Periodic Table:

Mendeleev did not imagine the discovery of inert elements, therefore no place was left by him in his periodic table for these elements. After the discovery of inert gases (later called the noble gases), a new group was added to accommodate these elements to his Periodic Table which is called zero group. Similarly, the lanthanides and actinides could not find the proper place in his periodic table. Later including these and other elements which were discovered after Mendeleeff, a modified table was prepared which has been given (Table 2.2).

Groups → Periods ↓	I		II		III		IV		V		VI		VII		VIII	O (Zero)																				
	A	B	A	B	A	B	A	B	A	B	A	B	A	B																						
1	H 1.0079															He 4.00																				
2	Li 6.94		Be 9.01		B 10.81		C 12.01		N 14.01		O 16.00		F 19.00			Ne 20.18																				
3	Na 22.99		Mg 24.31		Al 26.98		Si 28.09		P 30.97		S 32.06		Cl 35.45			Ar 39.95																				
4	K 39.10		Ca 40.08		Sc 44.96		Ti 47.87		V 50.94		Cr 52.00		Mn 54.94		Fe 55.84		Co 58.93		Ni 58.69		Cu 63.55		Zn 65.37		Ga 69.72		Ge 72.64		As 74.92		Se 78.96		Br 79.90		Kr 83.80	
5	Rb 85.47		Sr 87.62		Y 88.91		Zr 91.22		Nb 92.91		Mo 95.94		Tc (98)		Ru 101.07		Rh 102.90		Pd 106.42																Xe 131.29	
6	Cs 132.91		Ba 137.33		La 138.91		Hf 178.49		Ta 180.95		W 183.84		Re 186.21		Os 190.23		Ir 192.22		Pt 195.08														Rn (222)			
7	Fr (223)		Ra (226)		Ac (227)		X		X		X		X		X		X		X		X		X		X		X		X		X					

Period → 6 Succeeding 18	Ce 140.12	Pr 140.91	Nd 144.24	Pm (145)	Sm 150.36	Eu 151.96	Gd 157.25	Tb 158.93	Dy 162.50	Ho 164.93	Er 167.26	Tm 168.93	Yb 173.04	Lu 174.97	Lanthanides
Period → 7 Succeeding 18	Th 232.04	Pa 231.04	U 238.03	Np (237)	Pu (244)	Am (243)	Cm (247)	Bk (247)	Cf (251)	Es (252)	Fm (257)	Md (258)	No (259)	Lr (262)	Actinides

N.B.1. This is a representation of the elements in a tabular form based on the increasing atomic weights and properties of the elements.
2. The atomic weights quoted in the brackets are given to the numbers of significant figures only.

Table 2.2 Modified form of the Mendeleev periodic table based on atomic weight.

This table has following characteristics:

- (i) This table contains nine vertical columns or groups including the zero group.
- (ii) Except the elements of zero group and eighth group, all the groups have been divided into A and B sub groups. The elements of subgroup A have been kept on left side and those of B on the right side of the group. Elements of a subgroup have more similarities than those placed in the other sub group of the same group. For example, elements of subgroup I A (viz., Li, Na, K, Rb, Cs, etc.) have almost similar properties but differ from subgroup IB elements (viz., Cu, Ag, Au).
- (iii) The atomic weights of the elements increase regularly on moving from top to bottom in a column and, in general, in a period with few exceptions.

(iv) The number of horizontal rows has been kept the same but the nomenclature of periods (given in point v of Mendeleev's original periodic table) has been changed in the modified table. The first three periods, in this case, are known as short periods containing 2, 8 and 8 elements and the last four are called the long periods though the number of elements is 18 in the fourth and fifth periods and 32 in the sixth period. Seventh period is still incomplete. It may be noted here that there is regular variation in the properties of elements from left to right in a period.

(v) By the year 1900, some 30 more elements had been added to the list of elements. These along with those discovered later have been given in the table.

(A) Lothar Meyer's arrangement:

German chemist Lothar Meyer, in 1870 proposed independently a more extensive tabulation of the elements based on regular periodic recurrence of properties. He calculated the atomic volumes of the known elements i.e. volume occupied by one mole of the elements (in cm^3) in the solid state. Thus

$$\text{Atomic volume} = \frac{\text{mass of one mole}}{\text{density}}$$

When he plotted these atomic volumes against the corresponding atomic masses, a curve with sharp peaks and broad minima was obtained. This idea could not get wide acceptance and was not taken for further work by scientific community.

(B) Modern Periodic law (Moseley's Periodic Law).

This is also called Moseley's periodic law. Henry Moseley, a British physicist, in 1911-12, discovered a new property of the elements called **atomic number** which is equal to the total number of protons in the nucleus of the atom of an element (this is also equal to the number of electrons in the atom). He correlated this property with the physical and chemical properties of the elements. This led Moseley to predict that most of the defects of Mendeleeff's periodic table could be removed if the classification of the elements is done on the basis of atomic number rather than the atomic weight. He, thus, modified the periodic law and stated that "**the properties of the elements are the periodic functions of their atomic numbers**". Meaning thereby, if the elements are arranged in the increasing order of their atomic numbers, the recurrence of properties of the elements takes place at regular intervals. The elements with similar properties fall in the same vertical columns (or groups) and are called elements of that family.

Modern or Long form of Periodic Table:

This table is also known as Bohr’s periodic table and is based on the atomic number, which is a fundamental property of the elements, and Moseley’s periodic law. This table helps us to understand the cause of periodicity of properties, i.e. recurrence of similar properties at certain regular intervals viz., 2,8,18, and 32 which are referred to as magic numbers. This is because the atomic number of elements in a group increases by magic numbers at various steps. This is said to be attributed to the electronic arrangement in the atoms of elements.

The modern periodic table has 18 vertical columns called groups or families and 7 horizontal rows called periods. This has been given in (table 2.3).

Periodic Table of the Elements

The periodic table shows elements grouped into 18 vertical columns (groups) and 7 horizontal rows (periods). The groups are labeled as follows: 1 IA, 2 IIA, 3 IIIB, 4 IVB, 5 VB, 6 VIB, 7 VIIB, 8 VIII, 9 VIII, 10 VIII, 11 IB, 12 IIB, 13 IIIA, 14 IVA, 15 VA, 16 VIA, 17 VIIA, 18 VIIIA. The elements are color-coded according to their properties, as shown in the legend below the table:

- Alkali Metal (Pink)
- Alkaline Earth (Orange)
- Transition Metal (Yellow)
- Semimetal (Light Green)
- Nonmetal (Green)
- Basic Metal (Light Blue)
- Halogen (Dark Blue)
- Noble Gas (Light Purple)
- Lanthanide (Purple)
- Actinide (Dark Purple)

Diagram illustrating the information provided for an element (Aluminum):

- Atomic Number** → 13
- Symbol** ← Al
- Name** → Aluminium
- Atomic Weight** ← 26.982
- Electrons per shell** → 2-8-3

Table 2.3 Modern or long form of the periodic table.

(Source : <https://www.snexplores.org/article/scientists-say-periodic-table>)

The detailed discussion of the modern periodic table is given below:

Groups:

In terms of the electronic configuration/arrangement in atoms of the elements, a group consists of elements whose atoms have the same outer most shell electronic configuration (except some of the higher homologues of iron triad). According to IUPAC (International Union of Pure and Applied Chemistry), the groups are numbered as 1,2,3.....17,18. Also there is yet another system in practice among the authors in chemistry according to which groups are named as IA, IB, IIA, IIB, IIIA, IIIB.VIIA, VIIB, VIII and zero group in place of numbering the groups from 1 to 18. In the **table 2.3**, both the systems of numbering the groups have been given. At the same time, the elements have been allocated the blocks in the table *viz.*, groups 1 or (IA) and 2 or (IIA) have been placed in s-block, the groups 13 or (IIIA), 14 or (IVA).....17 or (VIIA) and 18 or (zero group) have been included in p-block. These elements of s and p-block (total 8 columns) are collectively called **main group elements**. The elements placed in s-block and p-block except the elements of groups 18 (zero group) are also known as **representative elements** and zero group elements are called inert or noble gases. The elements of the groups 3 or (IIIB), 4 or (IVB),.....7 or (VIIB), 8 to 10 or (VIII),11 or (IB) and 12 or (IIB) (total ten vertical columns) have been placed in d-block (also called transition elements). There are 28 elements arranged separately in two horizontal rows at the bottom of the main body of the periodic table, each row containing 14 elements. These have been included in f-block also known as innertransition elements or rare earth metals. First row of the elements is called 4f-block elements or lanthanides because they all are having almost similar properties and follow the element lanthanum. The second row is the 5f-block elements or actinides as they fall after actinium and also have almost similar properties.

The transition elements have been placed between s-and p-block elements and inner transition elements within transition elements.

Periods:

The modern periodic table has seven periods. Each period begins with alkali metal (except first one) and ends at a noble gas. The elements in the periods have also been arranged in the

increasing order of their atomic numbers and it increases by one unit at each step. The first three periods are known as short periods:

The elements of first period are H_1 and He_2 only (2 elements) The second period contains the elements from Li_3 to Ne_{10} (8 elements) and the third period includes the from Na_{11} to Ar_{18} (8 elements). The next three periods are collectively called long periods and include the elements as follows:

Fourth period: potassium (K, $Z= 19$) to krypton (Kr, $Z = 36$) (18 elements)

Fifth period: rubidium (Rb, $Z = 37$) to xenon (Xe, $Z = 54$) (18 elements)

Sixth period: caesium (Cs, $Z = 55$) to radon (Rn, $Z = 86$) (32 elements)

Seventh period: francium (Fr, $Z = 87$) to copernicium (Cn, $Z = 118$) (32 elements)

The seventh period will be completed at $Z = 118$ (a noble gas) but at present it is incomplete. All the elements of this period are radioactive.

The elements of third period except Ar ($Na_{11} - Cl_{17}$) are called typical elements.

The typical feature of the long form of periodic table is that the elements of 4th, 5th and 6th periods which fall under main group elements are sometimes called the “**normal elements**” because they resemble the elements of 2nd and 3rd periods below which they are placed. The 6th period also includes 14 elements ($Z = 58$ to 71) which follow lanthanum (La_{57}) and hence are known as lanthanones or lanthanides. The 7th Period contains another series of 14 elements ($Z = 90$ to 103) following actinium (Ac_{89}), therefore these elements are called actinones or actinides. The elements beyond uranium (U, $Z = 92$) viz., $Z = 93$ to 103 (neptunium to lawrencium) are known as trans- uranic elements and have been prepared artificially in the laboratory.

Lanthanides: Ce_{58} 14 elements Lu_{71}

Actinides: Th_{90} 14 elements Lr_{103}

In general, all the elements of the long form of periodic table have been divided into four categories:

(i) **Representative elements:**

These are the main group elements including the groups 1,2,13.....17 which have either ns^1 or ns^2 and $ns^2 p^x$ ($x = 1-5$) outer shell electronic configuration where n is the highest value of

principal quantum number. All these elements have been placed in subgroups A of the periodic table.

(ii) **Noble gases:**

These also fall within main group elements and include group 18 (or zero) elements. These all have completely filled s- or s- and p-subshells of outer most or ultimate shell with highest n value, i.e. ns^2 or ns^2p^6 (ns^2 for He). These have also been placed in subgroup A of periodic table.

(iii) **Transition metals:**

These are the elements of groups 3 to 12 and in general have incomplete d-subshell of the penultimate shell and filled s-subshell of ultimate shell with highest n-value. But the elements of some of the groups also have incompletely filled s-subshell of the ultimate shell in addition to incompletely filled d-subshell of the penultimate shell. All these elements have been placed in subgroups B of the periodic table.

(iv) **Innertransition elements:**

These elements are said to belong to group 3 or (IIIB) due to close similarity in their chemical properties with those placed in group 3. These elements generally have incompletely filled (n-1) d and (n-2) f-subshells.

According to their electronic configuration and the type of subshell to which the last of differentiating electron enters in the atom of the elements, the elements in the modern periodic table have been classified into four blocks i.e. s, p, d and f-block elements.

(i) **s-Block elements:**

All these elements are metals and solid except H and He which are gases. These are the elements in which the last electron enters the s-subshell. The elements of group 1 (alkali metals, viz., Li, Na, K, Rb, Cs, Fr) and group 2 (alkaline earth metals, viz., Be, Mg, Ca, Sr, Ba, Ra) belong to this block in addition to hydrogen (H) and helium (He). The general valence shell electronic configuration of these elements is ns^x ($x = 1$ or 2) where n is the number of valence shell or number of period which the element belongs to.

(ii) **p-Block elements:**

These elements in which the differentiating electron enters the orbitals of p-subshell of the valence or outer most shell are called p-block elements. The elements of groups 13 to 18 (except He with configuration $1s^2$) belong to this block. The group number and the elements contained in them are shown here:

Group 13 : B, Al, Ga, In, Tl

Group 14	:	C,	Si,	Ge,	Sn,	Pb
Group 15	:	N,	P,	As,	Sb,	Bi
Group 16	:	O,	S,	Se,	Te,	Po
Group 17	:	F,	Cl,	Br,	I,	At
Group 18	:	Ne,	Ar,	Kr,	Xe,	Rn

The general valence shell electronic configuration of these elements in $ns^2 np^x$ ($x=1$ to 6) and n is the number of shell. The elements of this block exist in all the three states of matter *viz.* solid, liquid and gas. Most of them are non- metals and the rest are metals and metalloids (or semimetals).

(iii) d-Block elements:

The elements in which the last electron enters the orbitals of $(n-1)$ d subshell, (i.e. the subshell of penultimate shell) and d-orbitals are, thus, being progressively filled are known as d-block elements. These elements are also termed as **transition elements** and have been placed in the middle between s-block and p-block elements in the periodic table. Thus, these elements serve as a bridge or transition between highly electropositive s-block and highly electronegative p-block elements thereby being responsible for gradual change in the properties along a period. Hence the name, transition elements has been given to them. These include the elements of group 3 to group 12 (ten columns). These have further been categorised into 3d, 4d, 5d and 6d series depending on the shell number whose d-orbitals are being filled. Each of these series contains ten elements as given below:

3d series: scandium (Sc, $Z = 21$) to zinc (Zn, $Z = 30$)

4d series: yttrium (Y, $Z = 39$) to cadmium (Cd, $Z = 48$)

5d series: lanthanum (La, $Z = 57$), hafnium (Hf, $Z = 72$) to mercury (Hg, $Z = 80$)

6d series: actinium (Ac, $Z = 89$), rutherfordium (Rf, $Z = 104$) to ornesson(Og,, $Z = 118$)

The general valence shell electronic configuration of these elements is $(n-1) d^x ns^{1or2}$ ($x = 1$ to 10). All these elements are metals and solid except Hg (a liquid).

(iv) f-Block elements:

In these elements, the last or differentiating electron, in general, enters the orbitals of $(n-2)$ f-subshell, i.e. the subshell of antipenultimate shell. All these elements are metals and solids. These elements are also called **inner transition elements** because they have incomplete f-subshell as well as incomplete d-subshell and fall within d-block elements. These elements have been divided into two series of 14 elements each, as follows:

4f-series elements (lanthanides): cerium (Ce, $Z = 58$) to lutetium (Lu, $Z = 71$)

5f- series elements (actinides): thorium (Th, $Z = 90$) to lawrencium (Lr, $Z = 103$)

The general valence shell electronic configuration of these elements is $(n-2)f^{0-14}(n-1)d^{0-2}ns^2$.

It has been noticed that for s and p-block elements, the outermost shell itself is the valence shell. For d-block elements, two subshells *viz.*, $(n-1)d$ and $n-s$ subshells taken together form the valence shell. For f-block elements, three subshells *viz.*, $(n-2)f$, $(n-1)d$ and $n-s$ subshells jointly form the valence shell. This is due to nearly similar energy of these subshells. A valence shell is that shell of the atoms of the elements, from which the electrons are used for bond formation or chemical combination.

For long form of the periodic table, it may be noted that the s-block elements (group 1 and 2) have been placed in the extreme left portion of the table and the p-block elements are kept in the extreme right portion. The middle portion includes d-block elements. At the bottom, f-block elements have been placed separately in two series/rows.

Merits and demerits of modern periodic table

By taking the atomic number as the basis for the classification of the elements in the modern periodic table, most of the demerits of Mendeleeff's periodic table have been removed.

- (i) The main characteristic of the modern or long form of the periodic table is that the classification of the elements has been made on the basis of their atomic number which gives an information regarding the valence shell electronic configurations of the elements. If we know the electronic configuration or the atomic number of an element, we can find out its position in the periodic table, i.e. to which group and period that element belongs. For example, for an element the valence-shell electronic configuration is $3s^23p^5$. This gives us the information that 3 is the value of n , i.e. the period and there are 7 electrons in the valence shell, means the element belongs to VIIA group. Therefore, the element is a member of VIIA group (group 17) and 3rd period.
- (ii) The subgroups have been placed separately in the modern periodic table thereby making it easy to have the information regarding the properties of the elements.
- (iii) The modern periodic table still has the drawback regarding the position of hydrogen which shows some properties similar to those of the group 1 elements (i.e. alkali metals) and some with the group 17 elements (i.e. halogens). Also the lanthanides and the actinides have not yet been included in the main body of the periodic table.

Nomenclature of the elements with $Z = 104$ and beyond

A systematic naming scheme was approved by IUPAC in 1977 for the new elements discovered around that period or would be discovered there afterhaving $Z \geq 104$. It was decided that a three-letter symbol derived directly from the atomic number would be used by using following numerical roots:

0	1	2	3	4	5	6	7	8	9
nil	un	bi	tri	quadpent	hex	sept	oct	enn	

These names and symbols can be used for elements with $Z = 104$ and beyond. These trivial names have been internationally accepted. Hence, the element with $Z = 104$ is un-nil-quadium (Unq), that with $Z = 106$ is un-nil-hexium..... and the elements with $Z = 109$ is un-nil-ennium (Une) etc.

The general names of the elements from Rf ($Z = 104$) to Cn ($Z = 112$) are given here:

Symbol	Atomic Number	Name
Rf	104	Rutherfordium
Db	105	Dubnium
Sg	106	Seaborgium
Bh	107	Bohrium
Hs	108	Hassium
Mt	109	Meitnerium
Ds	110	Darmstadtium
Rg	111	Roentgenium
Cn	112	Copernicium.

Earlier, the elements with $Z = 104$ was named as kurchatovium (Ku) and $Z = 105$ as hahnium (Ha)

Periodicity of properties

In the modern periodic table, the term periodicity of properties implies that the elements of similar properties reappear at a certain regular intervals of atomic numbers. On examining the

properties of elements, it has been found that the elements of the same group have similar properties. These numbers at which this repetition occurs, are 2,8,18 and 32, i.e. we have to pass these numbers to come across an element of similar properties in a group. These numbers are referred to as magic numbers as stated earlier.

Cause of periodicity

When we look into the electronic configuration of the elements, we find that all the elements belonging to a particular group have similar outer or valence shell electronic configuration. For example, elements of group 1 (IA) have ns^1 , those of group 3(IIIB) have $(n-1)d^1ns^2$, the elements of group 13 (IIIA) have ns^2p^1 and those of group 17 (VIIA) have ns^2p^5 valence shell electronic configuration. Because of similar valence shell electronic configuration/arrangement, the elements of a particular group have similar properties.

2.4 SUMMARY

The summary of the this unit is the :

- The history of the periodic table i.e. how the historical attempts were taken to develop a classification of elements system in a manner which could facilitate their study, during the time of Dobereiner, Duma and Newlands.
- The laws of periodic table and on the basis of these laws, the attempts to classify elements have also been exhaustively discussed.
- In the light of these laws, the elements, arranged in the tabular form, have been given, viz. Mendeleeff's periodic table, Modified form of Mendeleeff's periodic table (both on the basis of atomic weights) and modern periodic table on the basis of atomic number.
- In addition to this, the elements have also been classified in the blocks (with general characteristics of each block). A concise description of the periodicity of properties and its cause have been discussed.

2.5 TERMINAL QUESTIONS

- i) Write a concise note on Dobereiner's law of triads.
- ii) Discuss in short, the Newland's law of octaves.
- iii) State the Mendeleeff's periodic law.

- iv) Give a brief discussion of Mendeleeff's periodic table.
- v) State and explain the merits and demerits of Mendeleeff's periodic table.
- vi) Give a brief account of modern periodic law.
- vii) Discuss the main features of modern periodic table.
- viii) What are the transition elements and why are they called so?
- ix) Write a brief note on inner transition elements.
- x) What is the cause of periodicity of properties in the elements in periodic table?
- xi) What are the p-block elements?

2.8 REFERENCES

1. Principles of Inorganic Chemistry: B. R. Puri, L.R. Sharma & K. C. Kalia, Milestone Publishers and Distributors, Daryaganj, Delhi (2013).
2. Selected topics in Inorganic Chemistry: W.U. Malik, G.D. Tuli & R.D. Madan, S. Chand & Co. Ltd., New Delhi (1993).
3. Comprehensive Inorganic chemistry: Sulekh Chandra, New Age International (Pvt.) Ltd., New Delhi (2004).
4. The Nature of the Chemical Bond: Linus Pauling, 3rd Edn., Cornell University Press, New York (1960).
5. A Simple Guide to Modern Valency Theory: G.I. Brown, Revised Edn., Longmans Green, London (1967).
6. Advanced Inorganic Chemistry: Satya Prakash, G.D. Tuli, S.K. Basu and R.d. Madan, Vol. I, 7th ed., S. Chand & Co. Ltd, New Delhi (1998).
7. Shriver and Atkins' Inorganic Chemistry: Peter Atkins *et. al.*, 5th Edn., Oxford University Press, New York (2010).

UNIT : 3 PERIODIC PROPERTIES

CONTENTS:

- 3.1 Introduction
- 3.2 Objective
- 3.3 Periodic Properties
 - 3.3.1 Atomic and ionic radii
 - 3.3.2 Ionization energy
 - 3.3.3 Electron affinity
 - 3.3.4 Electronegativity
- 3.4 Trends in periodic table
- 3.5 Summary
- 3.6 Terminal Question
- 3.7 Answers
- 3.8 References

3.1 INTRODUCTION

In the previous chapter we describe the history of the periodic table and different laws of the periodic table. In this chapter we focus on the periodic properties viz. atomic and ionic radii, atomic volume, ionization potential (or energy), electron affinity or affinity energy and electronegativity and properties associated with them, viz. oxidizing and reducing properties, metallic (or electropositive) and non-metallic (or electronegative) properties are the periodic functions of their atomic number. Hence the term periodic means the recurrence of similar properties of elements after certain regular intervals, also called the periodicity. These properties have been found to depend on the electronic configuration of the elements. It means the cause of periodicity in properties of elements appears to lie in the recurrence of similar valence shell configuration of their atoms at certain regular intervals. Though, these properties apply up to some extent to all the elements of the periodic table, yet special emphasis will be laid down on the main group elements while taking the examples of the applications of the properties.

3.2 OBJECTIVE

In the present chapter you will be able to learn about the :

- The objective of writing the subject matter of this unit is to provide the readers an adequate knowledge of the properties of atoms of the elements which are called atomic or periodic properties.
- A sincere attempt has been made to provide the information regarding the size of the atoms/ions and their determination, effect of energy supplied to an atom of the elements, the behavior of the atoms towards the electrons trying to enter the region of their influence as well as those lying between the atoms as bonding pairs, variation of atomic properties of elements along the periods (horizontal rows) and down in groups (vertical columns) and some other interesting facts related to these properties.

3.3. PERIODIC PROPERTIES

3.3.1 Atomic and Ionic Radii:

These terms correspond to the size of the atoms and ions which are represented by the magnitude of their radii. Atomic radii, in general, are used for the distance between the nucleus and electron cloud of the outer most shell of the atoms. Since it is impossible to isolate an individual atom or ion and at the same time, the electron cloud, according to wave mechanical concept, is said to come closer to the nucleus at one moment and to go away from it at the other moment, i.e. it does not remain at constant distance from the nucleus, hence it is rather impossible to measure this distance by any means. These quantities are, however, generally derived indirectly from the measured distance between the nuclei of two bonded atoms in a gaseous molecule, generally known as inter nuclear distance (or bond distance) or between the nuclei of two neighbouring ions in crystalline solids called inter ionic distance.

The experimental techniques like Infrared or microwave spectroscopy, X-ray diffraction, electron diffraction etc. are used to determine the internuclear distance in covalent molecules and interionic distance in ionic substances. These determinations become essential to correlate certain physical properties of elements with them because density, melting point, boiling point etc. are related to the size of atoms.

Classification of Atomic Radii

For the purpose of feasibility, the atomic radii of the elements have been explained in three operational categories, as follows:

Atomic radii:

- A. Covalent radii
- B. Metallic or crystal radii
- C. van der Waals' radii

A. Covalent radii

Covalent molecules may be formed by two similar (A_2 type) or two dissimilar atoms (AB type). Hence, covalent radius of an atom is conveniently defined as “**half of the distance between the nuclei of two atoms of the same element bonded together in a molecule by a single covalent bond**”. Thus, for the atom A in A_2 type molecule in which two A atoms are linked by a single bond, covalent radius, denoted by r_A , is given as:

$$d_{A-A} = r_A + r_A = 2r_A \quad \dots\dots\dots(3.1)$$

$$\text{or } r_A = \frac{d_{A-A}}{2} \dots\dots\dots (3.2)$$

where d_{A-A} is the internuclear distance between two A atoms in A_2 molecules; r_A in equation 3.2 is known as single bond covalent radius of atom A and is used for a gaseous diatomic molecule. For example, internuclear distance (d_{H-H}) in H_2 molecule is 0.74 \AA . The covalent radius of H – atom, $r_H = \frac{d_{H-H}}{2} = \frac{74}{2} \text{ pm} = 0.37 \text{ \AA}$. Similarly, the internuclear distance (d_{Cl-Cl}) atom (r_{Cl}) may be calculated as:

$$(\text{\AA} = 10^{-8} \text{ cm})$$

$$r_{Cl} = \frac{d_{Cl-Cl}}{2} = \frac{1.98}{2} \text{ pm} = 0.99 \text{ \AA}.$$

For atoms bonded together to form an extensive three dimensional network, atomic radius is simply **“half of the distance between the nuclei of two neighbouring atoms”** i.e.

$$r_{cov} = \frac{\text{inter nuclear distance}}{2}$$

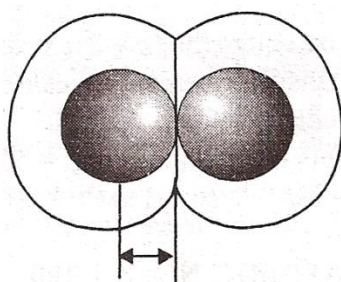

Fig. 3.1 Diatomic molecule
(covalent radius)

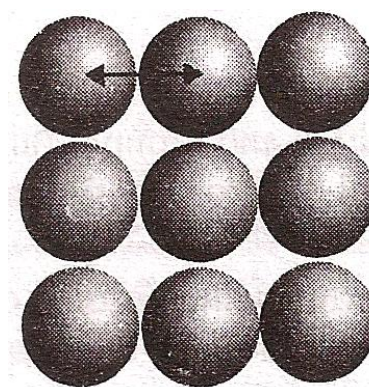

Fig. 3.2 Bulk of atoms
(internuclear distance)

In hetero nuclear molecules (e.g. AB type), the single bond covalent radius can be calculated as given below;

- (a) When the atoms A and B bonded together by purely covalent bond and the electronegativities of these two atoms are almost same, the internuclear distance is equal to the sum of radii of A and B;

$$d_{A-B} = r_A + r_B \text{ (when } \chi_A = \chi_B) \dots\dots\dots(3.3)$$

The internuclear distance, d_{A-B} , can be measured by experimental method and if r_A or r_B (any one) is known, the other unknown term (r_A or r_B) can be calculated by using the equation 3.3.

The value of r_A or r_B may be obtained from $r_A = \frac{dA - A}{2}$ or $r_B = \frac{dB - B}{2}$.

(b) If the electronegativities of the two combining atoms are not the same ($\chi_A \neq \chi_B$), then the experimental value of d_{A-B} has been found less than the calculated value obtained as a sum of covalent radii r_A and r_B of the heteroatomic molecule. For example,

(i) in $(CH_3)_3 N$ molecule,

$$(d_{N-C})_{\text{exp}} = 1.47 \text{ \AA}$$

$$\text{and } (d_{N-C})_{\text{cal.}} = r_N + r_C = 0.75 + 0.77 = 1.52 \text{ \AA}$$

(ii) In HF molecule,

$$(d_{H-F})_{\text{exp}} = 0.92 \text{ \AA}$$

$$\text{and } (d_{H-F})_{\text{cal.}} = r_H + r_F = 0.37 + 0.72 = 1.09 \text{ \AA}$$

This shortening of d_{A-B} bond length may be due to the following factor:

(a) The higher ionic character of the bond between A and B atoms with larger difference in electronegativities of the hetero atoms. In such a case more electronegative atom attracts the shared pair of electrons towards itself thereby developing slight negative charge on that atom due to accumulation of electrons closer to it and positive charge of equal magnitude on the other atom. This development of opposite charges brings the atoms closer to each other. That is why the experimental value of d_{A-B} is less than the calculated value. Some correction measures have been suggested in such cases.

In order to compensate this, the following correction has been suggested:

$$d_{A-B} = r_A + r_B - 0.09 (\chi_B - \chi_A) \quad \dots\dots(3.4)$$

(schoemaker and Stevenson)

Still, if the discrepancy remains, another correction measure may be applied (Porterfield):

$$d_{A-B} = r_A + r_B - 0.07 (\chi_B - \chi_A)^2 \quad \dots\dots(3.5)$$

(b) The other factors in some cases, may be multiplicity of bonds and effective nuclear charge which cause reduction in the length of covalent bonds and as a consequence in covalent radii. For example, it has been found that single bond covalent radius > double bond

covalent radius > triple bond covalent radius. This is because the formation of multiple bonds brings the combining atoms closer to each other and the bond length is reduced.

Table 3.1: Covalent radii (single bond radii) for hydrogen and some p-block (non-metallic and metalloid) elements except noble gases (in Å)

	s-block			p-block			
Group number	1	2	13	14	15	16	17
Elements with covalent radii	H	-	B	C	N	O	F
	0.37	-	0.82	0.77	0.75	0.73	0.72
	-	-	-	Si	P	S	Cl
			-	1.11	1.06	1.02	0.99
				Ge	As	Se	Br
				1.22	1.20	1.16	1.14
				-	Sb	Te	I
					1.40	1.36	1.33

Among the s- and p-block elements, only the non-metallic elements and metalloids have been taken to tabulate the covalent radii because the formation of covalent bond, in general, is the exclusive property of the non-metals and metalloids. Noble gases have also been excluded from the table because these, except a few, do not participate in covalent bond formation.

Factors affecting the magnitude of covalent radii

There are many factors which influence the magnitude of covalent radii. Some of them are:

(i) **Effective nuclear charge (Z_{eff})**

As the value of Z_{eff} increases, the force of attraction between the nucleus and outermost shell electrons also increases thereby decreasing the covalent radii of the elements, i.e. $r_{\text{cov.}} \propto \frac{1}{Z_{\text{eff}}}$

(ii) **Principal quantum number (n)**

This gives the number of shells present in the atoms of the elements. As the value of principal quantum number increases the outermost electrons get farther away from the nucleus and covalent radius also increases provided other factors remain the same, i.e. $r_{\text{cov.}} \propto n$

(iii) **Multiplicity of Bonds**

With the increase in the number of bonds between the atoms, these come closer to each other thereby decreasing the covalent radii i.e. $r_{\text{cov.}} \propto \frac{1}{\text{multiplicity of bonds}}$

B. Metallic or Crystal Radii

These terms are taken synonymous to covalent radii of metal atoms, though metals generally do not form covalent compounds except hydrides and organo-metallic compounds. Further, metals are assumed to be closely packed spheres in the crystals in which their outer boundaries touch one another. Thus metallic or crystal radius may be theoretically defined as **“half of the distance between the nuclei of any two adjacent metal atoms in close-packed metallic crystal”** For example, the internuclear distance between any two adjacent sodium atoms in a crystal of sodium metal is 3.80 Å. Hence crystal or metallic radius of sodium metal is $\frac{3.80}{2} = 1.90 \text{ Å}$

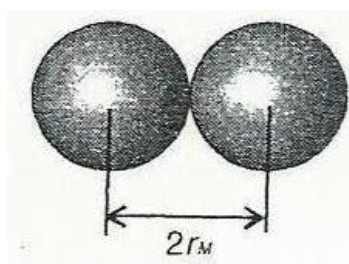

Fig. 3.3 Metallic radius

In practice, in the metallic phase, atomic volumes of metal atoms can be determined from their atomic masses and respective densities. Thus, atomic volume = $\frac{\text{mass}}{\text{density}}$. From these data, metallic radii can be obtained. It has been found that the covalent radii of metal atoms determined in metal hydrides and organometallic compounds and metallic radii determined from atomic volumes in metallic phase have almost similar values though not exactly equal. Hence, the term metallic covalent radii can be used. The metallic radii have slightly higher

(10%) value than metallic covalent radii because individual bond in metals is weaker and longer than the covalent bond.

Group number	1	2	13	14	15	16
Elements with metallic radii	Li	Be	-	-	-	-
	1.55	1.12	-	-	-	-
	Na	Mg	Al	-	-	-
	1.90	1.60	1.43	-	-	-
	K	Ca	Ga	-	-	-
	2.35	1.97	1.41	-	-	-
	Rb	Sr	In	Sn	-	-
	2.48	2.15	1.66	1.62	-	-
	Cs	Ba	Tl	Pb	Bi	Po
2.67	2.22	1.71	1.75	1.70	1.76	

Table 3.2 Metallic radii of main group metals (in Å)

C. van der Waals' radii

In solid state, the nonmetallic elements usually exist as aggregations of molecules. Although the bonding within a nonmetal molecule is more or less covalent in character yet the binding force between the molecules is van der Waals' force. Thus each molecule assumes equilibrium position within the crystalline solid. It is to be noted that these forces are absent if the substances are in the gaseous state. van der Waals' radius can be defined as " **half of the distance between the nuclei of two non-bonded but adjacent atoms belonging to two neighbouring molecules**". These radii have higher values by 90-100% in lighter elements and 70-80% in heavier elements than covalent radii because of non-bonded type of binding force between the molecules. The values of van der Waals' radii are obtained from X-ray studies of various non-metallic elements in the solid state. On comparing the covalent radii

and van der Waals' radii of the nonmetallic elements, it is noted that the van der Waals' radii have higher values. Please refer to **table 3.2** and **table**

Group number	1	15	16	17	18
Elements with van der Waal's radii	H				He
	1.20				1.20
		N	O	F	Ne
		1.50	1.40	1.35	1.60
		P	S	Cl	Ar
		1.90	1.85	1.80	1.91
		As	Se	Br	Kr
		2.00	2.00	1.95	2.00
	Sb	Te	I	Xe	
	2.20	2.20	2.15	2.00	

Table 3.3

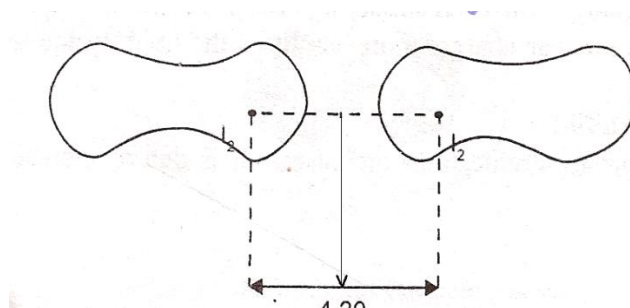

Fig. 3.3 van der Waals' radii

Periodic trends of atomic radii

(a) Variation in a period

The atomic radii (*viz.* covalent radii, metallic radii and van der Waals' radii) and hence the atomic size, in general, decrease on moving from left to right in a period. This is because the atomic number in a period increases by one unit at each step but the electrons in all the elements in a period enter the same outer or valence shell. Hence, there operates an increased force for attraction between these outer electrons and the nuclear charge. As a result, the atomic radius or atomic size decreases regularly except the noble gases. For example, we can take the elements of second period and hydrogen. The term covalent radius does not apply to the noble gases. van der Waals' radii are applicable to all nonmetallic elements including noble gases but the values for noble gases are exceptionally high due to larger repulsion among the monoatomic species with large number of electron.

One Å unit is equal to 10^{-10}m

Elements	H	C	N	O	F	Ne
Covalent radii (in Å)	0.37	0.77	0.75	0.73	0.72	-
van der Waals' radii (in Å)	1.20	-	1.50	1.40	1.35	1.60

(b) **Variation in a group**

On going down a group, the atomic sizes of elements increase continuously both in metals and non metals as is evident from the table of covalent radii, metallic radii and van der Waals' radii except the metals of third transition series whose atomic sizes are almost similar to those of second transition series metals. At the same time lanthanide series and actinide series of metals have decreasing trend in their metallic radii.

The regular increasing trend in atomic sizes among the main group elements is due to the introduction of new shell at each step in a group which produces larger effect than that produced by the increase in effective nuclear charge.

Ionic radii

Though, it is very difficult to define ionic radius, yet an approximate definition can be given as “the effective distance between the nucleus of an ion and the point up to which the nucleus exerts its attractive influence on the electron cloud of the ion”. Because it is rather impossible to determine the outer boundary of an ion, therefore if the ions in an ionic crystal are taken as spheres whose outer boundaries are touching one another, the interionic distance (or internuclear distance) may be supposed to be the sum of the radii of the two ions (an additive property).

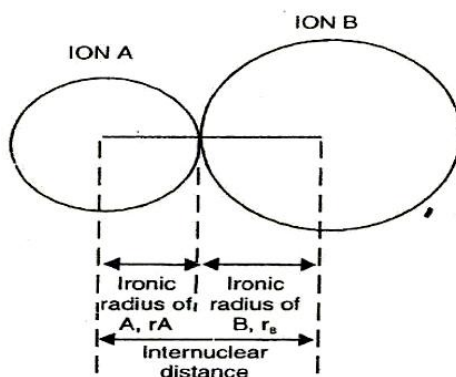

Fig. 3.4 The ionic radius

X-ray analysis of ionic crystals is used for measuring the equilibrium distance between the nuclei of the two adjacent ions called interionic distance in taking the ions as spheres. This distance is taken as the sum of the ionic radii of the two ions. e.g.

$$d_{C^+ - A^-} = r_{C^+} + r_{A^-} \quad \dots\dots(3.6)$$

This equation can be used to find out the ionic radius of a cation or an anion. The interionic distance $d_{C^+A^-}$ can be measured by experimental method and if the radius of any one ion is calculated by some other method, the radius of another ion can be obtained by using the above equation. For example, the inter nuclear distance between sodium and chloride ions ($d_{Na^+Cl^-}$) in NaCl crystal is 2.76 \AA and radius of sodium ion (r_{Na^+}) is 0.95 \AA . From these values we can calculate the radius of chloride ion (r_{Cl^-}) as follows:

$$d_{Na^+Cl^-} = r_{Na^+} + r_{Cl^-}$$

$$\text{Putting the values of } d_{Na^+Cl^-} \text{ and } r_{Na^+}, \text{ we get } 2.75 \text{ \AA} = 0.95 \text{ \AA} + r_{Cl^-}$$

$$\therefore r_{Cl^-} = 2.76 - 0.95 \text{ \AA} = 1.81 \text{ \AA}$$

Periodic trends of ionic radii

Periodic variation of ionic radii can be easily visualised in main group elements though it is, in general, applied for transition elements.

(a) **Variation in a period**

Since atomic size decreases along a period from left to right, the cationic or anionic size also decreases in the same direction. For transition elements this trend is observed if they are in the same oxidation state.

(b) **Variation in a group**

As we move down a group of main group elements, the cationic or anionic size increases regularly provided the elements are in the same oxidation state. Similar trend, in general, is observed for transition elements though the change in cationic size is very small or negligible between second and third transition series elements. Reverse trend has been observed in case of lanthanides and actinides where ionic size decreases in the series.

Some important facts regarding ionic radii are given below:

(i) **Ionic radii of isoelectronic species**

The isoelectronic species are the cations, anions and atoms of different elements having same number of electrons and same electronic configuration. For example, a common isoelectronic series with ten electrons, i.e. $1s^2 2s^2 2p^6$ configuration is given here with their radii;

Ion/atom	C ⁴⁻	N ³⁻	O ²⁻	F ⁻	Ne	Na ⁺	Mg ²⁺	Al ³⁺	Si ⁴⁺
Atomic numbers	6	7	8	9	10	11	12	13	14
Radius (Å units)	2.60	1.71	1.42	1.36	-	0.95	0.65	0.50	0.41

It is evident from this table that, as the atomic number (or nuclear charge) of the parent atoms from which the ions have been derived, increases the ionic radius decreases. This is because with the increase in the nuclear charge, the attractive force between the nucleus and the outer electrons also increases thereby the electrons come closer to the nucleus and consequently the size of the ions decreases.

(ii) A cation is smaller in size than its parent atom because a cation is formed by the removal of electron (s) from the neutral atom; hence the number of electrons becomes less than the number of protons (nuclear charge). As a result, the electrons are strongly pulled by the nucleus thereby causing a contraction in the size of the cation. Therefore, the cation is smaller in size than its parent atom.

(iii) An anion is larger in size than its parent atom. This is because, an anion is formed by the addition of extra electron (s) in a neutral atom. Thus the number of electrons becomes greater than that of protons (nuclear charge) and the electrons are loosely held by the nucleus. As a result, the anionic size becomes larger than the size of the parent atom.

(iv) For the cations or the anions of the same element in different oxidation states, the cationic size decreases but the anionic size increases with the increasing oxidation states, i.e. for anions: $r_{A^-} < r_{A^{2-}} < r_{A^{3-}} < r_{A^{4-}} \dots \dots \dots$ etc. and for cations $r_{C^{+}} > r_{C^{2+}} > r_{C^{3+}} > \dots \dots \dots$ etc. (C = cation, A = anion)

Factors affecting ionic radii

The main factors that affect ionic radii are as follows:

(a) Crystal coordination number (CCN)

With the increase in the crystal coordination number, the interionic distance also increases thereby increasing the ionic radii, For example, the radius of Cl^- ion (r_{Cl^-}) in CsCl crystal (C.C.N. = 8) is slightly higher than its radius in NaCl Crystal (CCN =6). This is because with the higher CCN, the number of ions surrounding a particular ion is greater, causing less attraction between the oppositely charged ions than that with lower CCN i.e. $r_{ion} \propto CCN$

(b) Radius ratio (R_r)

Radius ratio ($R_r = \frac{r_{C^+}}{r_{A^-}}$) also affects the magnitude of ionic radius. If the R_r is larger due to large cation and small anion, the anion-anion repulsion is less and the interionic distance becomes shorter than the sum of the ionic radii (i.e. $d_{C^+A^-} < r_{C^+} + r_{A^-}$) but if R_r is smaller due to small cation and large anion, the anion-anion repulsion is more and interionic distance is greater than the sum of the ionic radii (i.e. $d_{C^+A^-} > r_{C^+} + r_{A^-}$)

(c) Covalent character of Ionic Bond

Ionic radii decrease as the covalent character in ionic bond increases. $r_{ion} \propto \frac{1}{\text{covalent character}}$

3.3.2 Ionization energy (IE):

This term is related with the removal of electron (s) from the neutral atom and converting it into a positive ion (or cation). If the energy is supplied to an atom, its electron (s) may be promoted to a higher energy level and if this energy is sufficient enough, the electron (s) may completely be removed from it giving a cation. Thus “**the minimum amount of energy required to remove a loosely bound electron from an isolated gaseous atom of an element in its ground state is called its ionization energy**”. In the definition, gaseous atoms are specified because an atom in gas phase is uninfluenced by its neighbours and there is no intermolecular forces to take into account while measuring ionization energy. This can be shown as follows:

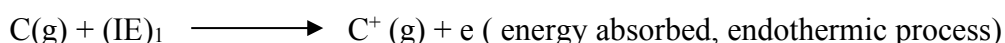

In this process, if one electron is removed, it is termed as the first ionization energy, $(\text{IE})_1$. For many electron atom, if more electrons are removed from an atom, the ejection of electrons occurs one by one in steps depending on the amount of energy absorbed/supplied. Thus corresponding to the removal of second electron, the energy is known as second ionization energy, $(\text{IE})_2$ and if third electron is removed, the corresponding energy which has to be supplied is called third ionization energy, $(\text{IE})_3$ and so on. Alternatively, these are also known as successive ionization energies. The sequence of ionization energies in their increasing order may be given as:

$$(\text{IE})_1 \ll (\text{IE})_2 \ll (\text{IE})_3 \dots \dots \dots (\text{IE})_n.$$

This is because when an electron is removed from a neutral atom to give a cation, the number of the remaining electrons of the cation becomes less than the nuclear charge and greater attractive force operates between these electrons and nucleus causing contraction in the size of cation. Therefore, more energy is required to remove another electron from the cation, i.e. $(\text{IE})_1 \ll (\text{IE})_2$. Due to the similar reason, still higher amount of energy is required to remove yet another electron, i.e. $(\text{IE})_2 \ll (\text{IE})_3$ and so on.

An alternative explanation for this observation may be given. Since, the magnitude of ionization energy is a measure of tightness with which an electron is held in the atom, hence higher the ionization energy, more tightly the electron is held in the atom and more difficult it is to remove it. The ionization energy is expressed in the units of kilojoules per mole (kJ/mole) or kilo calories per mole (k Cal/mole)

It has been observed that among the elements of the periodic table, the alkali metals have the least and the noble gases have the highest ionization energy values in the respective periods. Helium has the highest value and caesium possesses the lowest value of first ionization energy among all the main group elements.

Atomic Number (Z)	Element	(IE) ₁	(IE) ₂	(IE) ₃
1	H	1312	-	-
2	He	2373	5251	-
3	Li	520	7300	11850
4	Be	899	1757	14850
5	B	801	2430	3660
6	C	1086	2350	4620
7	N	1400	2860	4580
8	O	1314	3390	5300
9	F	1680	3370	6050
10	Ne	2080	3950	6120

Table 3.4: The successive ionization energy values (in kJ/ mole) of the first ten element

Factors affecting the magnitude of ionization energy

(i) Atomic Size (or The Principal Quantum Number)

As the principal quantum number for the outer electrons increases, the atomic size also increases and the ionization energy of the elements decreases and vice versa, i.e. $IE \propto \frac{1}{n \text{ or } r_{\text{atom}}}$. This can be seen in a group.

(ii) Nuclear charge

As the nuclear charge increases, other factors remaining the same, more and more attractive force operates between the nucleus and outer electron(s). Thus more energy is required for the removal of electron(s) and as a consequence, the ionization energy goes on increasing. This is observed along the periods, in general, $IE \propto$ nuclear charge.

(iii) Penetrating power of valence electrons

In a given shell, the penetrating power of the electrons decreases in the order $s > p > d > f$, therefore, ns electrons are more firmly held by the nucleus (due to highest penetrating power) than np – electrons followed by d and f electrons (due to their scattered orientation). Accordingly, the ionization energy decreases as follows: $ns > np > nd > nf$ i.e. $IE \propto$ penetrating power.

(iv) Shielding effect of inner electrons

In poly electron atom, the valence electrons are attracted by the nucleus and at the same time repelled by the inner shell electrons. As a result, the outer most electron experiences less attraction from the nucleus because inner electrons act as screen or shield between outer electrons and nucleus. This effect produced by inner electrons is called the shielding effect. Within a given shell, this effect decreases in the order: $s > p > d > f$. Thus, an increase in the number of inner or intervening electrons causes more shielding effect thereby decreasing the attractive force between the nucleus and outer electrons. Consequently the ionization energy also decreases, i.e. $IE \propto \frac{1}{\text{shielding effect}}$

(V) Stable electronic configuration

According to Hund's rule, half filled (*viz.* ns^1 , np^3 , nd^5 etc.) or completely filled orbitals (*viz.* ns^2 , np^6 , nd^{10} etc.) are more stable than the partially filled orbitals. Hence more energy is required to remove the electron (s) from such orbitals. This means that the ionization energy of an atom having half filled or completely filled orbitals in its ground state is relatively higher than expected normally from its position in the periodic table. The relative stability order of such orbitals has been found as $d^5 < p^3 < d^{10} \ll p^6$. For example, the ionization energies for Be ($2s^2$) and N ($2s^2 2p^3$) in the second period and Mg and P, the higher homologues of Be and N, in the third period are slightly higher than expected values. This is because of the extra stability of the electronic configuration of these elements, High values of ionization energy

for noble gas elements is also due to stable $ns^2 np^6$ (He - ns^2) configuration in the vacance shell, i.e. $IE \propto$ stable configuration.

To gain the necessary energy for the removal of electrons from an atom, a potential difference has to be applied across the sample of element. This potential difference giving the necessary energy is called the ionization potential.

Prionic trends

i) Variation along a period

On going from left to right in a period, there is, in general, an increase in the ionization energy values of the elements due to the effect of reduction in the atomic radii and increase in the nuclear charge by one unit at each step but the outer shell remaining the same (n is constant for the elements of a period). Thus, the electrons in these elements are being successively filled to the same shell. Such electrons shield each other poorly from the increasing nuclear charge. As a result, Z_{eff} increases which cause an increase in ionization energy.

There are some exceptions to this trend. Let us consider the elements of second period i.e. Li_3 to Ne_{10} for which the expected order of ionization energy is $Li < Be < B < C < N < O < F < Ne$. The experimental values, however, show that Be and N have higher IE values than those of the next elements, i.e. B and O. This anomaly can be explained on the basis of their stable electronic configurations, i.e. $Be (ns^2) > B (ns^2 np^1)$ and $N (ns^2 np^3) > O (ns^2 np^4)$ (please refer to the IE table of elements). This is evident from the ionization energy values of the above elements that it is easier to remove the last and loosely bound electron from B or O-atoms as compared to that from Be or N-atom and thus elements (B and O) have lower first ionization energy values than Be and N.

The elements of the transition series show irregular trends of ionization energies along their periods due to shielding effects and electronic configurations.

ii) Variation in a group

On going from top to bottom in a group of elements, the nuclear charge increases regularly. This must cause an increase in the IE values of the elements. At the same time, the atomic size also increases due to the introduction of a new shell at every next element in the group. This causes a decrease in the IE values of the elements. The effect of increased size is more

than that due to increased nuclear charge. The net result is the continuous fall in the values of ionization energy down the group.

Alternatively, this trend may also be explained by the fact given here. As we move down a group, the number of inner shell electrons called intervening electrons increases. As a result there is more shielding effect caused by the inner electrons on the outer electrons. This decreases the ionization energy values of the elements in a group.

There are some exceptions also. The first ionization energy of Ga₃₁, an element of fourth period is slightly higher than that of Al₁₃, the element of third period [(IE)₁ of Al = 577.6 kJ/mole and (IE)₁ of Ga = 578.8 kJ/mole] This is perhaps due to the poor shielding effect of 3d¹⁰ electrons.

Also, the third row of transition elements shows higher value of ionization energy as compared to second row elements. This is due to the decrease in size of these elements as a result of insertion of lanthanides in 6th period (Lanthanide contraction).

Application of ionization energy

(i) Prediction of electropositive character

The electropositive character of the elements is related to the ease with which the electron (s) could be removed from the atom of the elements. More electropositive is the elements, more easily the electron (s) can be removed. As we move down a group, the ionization energy of the elements decreases regularly and hence the electropositive character also increases accordingly. Across a period, the ionization energy of the elements, in general, increases means the electropositive character decreases from left to right. Alkali metals placed at the extreme left portion of the periodic table, are the most electropositive elements with low values of ionization energy.

(ii) Prediction of metallic and non-metallic character

The elements with low ionization energy are more metallic in nature because they can lose electrons easily. Hence metallic character increases from top to bottom in the groups and decreases along the period from left to right. The elements showing the opposite trend in ionization energy and periodic variation to that of metals are called the non-metals.

(iii) Prediction of reducing power of an element

Lower the value of ionization energy of an element, greater is its reducing power. The alkali metals with the lowest ionization energy values are the strongest reducing agents among all the elements.

3.3.3 Electron affinity (or affinity energy) (EA).

This term is related with the formation of an anion from a neutral atom of an element by the addition of electron (s). Thus, this is the tendency of the atom to gain the additional electron (s). The electron affinity (EA) of an element can be defined as the “**amount of energy released when an electron is added to the outer shell of an isolated gaseous atom of the element to produce the gaseous anion**”. This can be shown as: $A(g) + e \rightarrow A^-(g) - (EA)_1$ (electron affinity energy released). Evidently, this is an exothermic process. The expression actually shows the first electron affinity. Once the uninegative anion has been formed by accepting one electron by the neutral atom, addition of another electron (s) in this ion becomes more difficult due to repulsive force operating between the anion and the incoming electron. To overcome this repulsive force, extra energy has to be supplied to the electron which must actually be more than the energy released during the addition of electron, i.e. the energy supplied to electron > energy released during the addition of electron. The net energy change is the energy absorbed (supplied) by the electron, hence the addition of second or third etc. electron to the anion is an endothermic process:

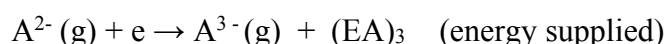
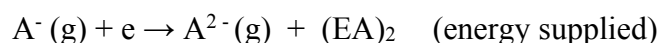

The electron affinity values for the elements of second period are given below:

Element	Li	Be	B	C	N	O	F
(EA) ₁ in kJ/mole	60	≤ 0	27	122	≤ 0	141	328

The electron affinity values of Be and N are shown zero because it is very difficult to add an extra electron to the outer shells of these elements due to extra stability of the electronic configuration.

The electron affinity values of halogens are very high because of the $ns^2 np^5$ outer shell electronic configuration and very strong tendency to accept the incoming electron thereby getting converted into the negative ions with noble gas configuration, i.e. $ns^2 np^6$. Though the first element of halogen group, is expected to have the highest value of EA, but its EA value is less than that of Cl. This is due to the smaller size and greater electron-electron repulsion in F-atom which opposes the entry of the incoming electron. The EA values of the noble gases are almost zero due to no tendency of accepting the additional electron because of stable $ns^2 np^6$ configuration. EA values of halogens and noble gas elements are given below (in kJ/mole):

Element	F	Cl	Br	I	At	He	Ne	Ar	Kr	Xe	Rn
$(EA)_1$ value	328	349	325	295	280	≤ 0	≤ 0	≤ 0	≤ 0	≤ 0	≤ 0

Factors affecting the electron affinity

All the factors which affect the ionization energy also affect the electron affinity. The main factors among them are discussed here:

(i) Atomic size

Smaller the atomic size, stronger is the attraction of nucleus for the incoming electron and hence greater is its electron affinity and vice versa, i. e. $EA \propto \frac{1}{\text{atomic size}}$ (as is seen along a period)

(ii) Effective nuclear charge (Z_{eff})

Greater is the effective nuclear charge of the elements, stronger is the attraction between it and the electron to be added to the atom. Thus with the increase in Z_{eff} , other factors remaining the same, electron affinity of the elements also increases, i.e. $EA \propto Z_{\text{eff}}$ (as is seen along a period).

(iii) Stable electronic configuration

The atoms of the elements with stable electronic configuration do not show any tendency to accommodate the incoming electron (s). Hence the EA values for such elements is almost zero. For example, the elements of 2nd group with ns^2 outer electronic configuration have zero

EA values. The elements of 15th group with ns^2np^3 outer electronic configuration have zero or very low EA values. The noble gases with ns^2np^6 stable configuration in the outer shell also have zero EA values i.e. do not have any affinity for the electron (s) to be added to them.

The electron affinity of an element can be determined by using the Born-Haber cycle.

Periodic trends of electron affinity

(i) Variation along the periods

In general, with few exceptions, the electron affinity values of the elements go on increasing on moving from left to right in a period, i.e. from alkali metals to halogens. This is because atomic size decreases and the effective nuclear charge increases along a period. Both these factors increase the force of attraction between the nucleus and the incoming electron which is added easily to the outer shell of the host atom. Exceptions are the elements of 2nd, 15th and 18th groups.

(ii) Variation in the groups

The electron affinity values go on decreasing when we move from top to bottom down in a group. On descending a group, the atomic size and the nuclear charge both increase regularly. The increasing atomic size tends to decrease the EA values while increasing nuclear charge causes an increase in these values. The net result is that the effect produced by the progressive increase in size more than compensates the effect produced by progressive increase in nuclear charge and hence EA values decrease regularly down the group.

3.3.4 Electronegativity (χ , chi)

In a homoatomic molecule, the bonding pair of electrons lies at the middle of internuclear space. But this is not true for a hetroatomic molecule. As a result polarity is developed on the hetero atoms of the molecule due to the shifting of the bonding pair of electrons towards one particular atom. For example, in H_2 or Cl_2 molecules, the bonded pair of electrons lies at the middle of two nuclei, i.e. is equally attracted by both the atoms. But in HF or like molecules, the bonded pair of electrons is attracted with stronger force by F atom (in HF) and thus, is shifted towards it from its expected middle position. This causes the development of slight negative charge on F and equal positive charge on H atom, therefore HF is a polar molecule.

This means an atom in a heteroatomic molecule with stronger affinity for bonding electrons is able to pull them towards itself and takes them away from the atom with weaker affinity for them. In the above example (*viz.* HF) F is said to have stronger affinity for bonded electrons as compared to that of hydrogen atom. To explain this tendency in heteroatomic molecules, Linus Pauling, in 1932, introduced the concept of electronegativity. According to him “**electronegativity is the relative tendency or power of an atom of an element in the heteroatomic molecules to attract the shared pair of electrons towards itself**”.

Methods of evaluating electronegativity

Various chemists have defined and proposed the methods for evaluating electronegativity. These are known as electronegativity scales.

(i) Pauling's Scale

Pauling's definition of electronegativity has been given in the beginning. He used thermodynamic data to calculate the electronegativity of different elements. He considered the formation of AB molecule by the combination of A₂ and B₂ molecules.



This reaction may also be written as

$\frac{1}{2} (A-A) + \frac{1}{2} (B-B) = A-B$ because A₂, B₂ and AB are covalent molecules. This is an exothermic reaction, means the formation of A-B molecules is accompanied by the release of energy, i.e. the bond dissociation energy of A-B covalent bond (E_{A-B}) is always higher than the mean of the bond dissociation energy of

A-A (E_{A-A}) and B-B (E_{B-B}) covalent bonds and $E_{A-B} > \frac{1}{2} (E_{A-A} + E_{B-B})$

Pauling proposed that the difference in the E_{A-B} and mean of E_{A-A} and E_{B-B} is related to the difference in electro negativities of A (χ_A) and B (χ_B)

$$\therefore \Delta = E_{A-B} - \frac{1}{2} (E_{A-A} + E_{B-B}) = 23 (\chi_B - \chi_A)^2 \quad (\text{where } \chi_B > \chi_A) \quad \dots\dots\dots (3.9)$$

$$\text{Thus, } \Delta = 23 (\chi_B - \chi_A)^2$$

$$\text{Or } \chi_B - \chi_A = 0.208 \sqrt{\Delta} \quad \dots\dots\dots (3.10)$$

In place of arithmetic mean, he later used the geometric mean of E_{A-A} and E_{B-B} and expressed the equation as:

$$\Delta' = E_{A-B} - (E_{A-A} \times E_{B-B})^{1/2} = 30(\chi_B - \chi_A)^2 \quad \dots\dots\dots(3.11)$$

$$\therefore \Delta' = 30 (\chi_B - \chi_A)^2$$

$$\therefore \chi_B - \chi_A = 0.182 \sqrt{\Delta'} \quad \dots\dots\dots(3.12)$$

Here χ_A and χ_B are the electronegativities of the atoms A and B. The factors 0.208 and 0.182 arise from the conversion of Δ measured in kCal/ mole into electron volts.

s-block

p-block elements

1	2	13	14	15	16	17	18
H							He
2.1							0
Li	Be	B	C	N	O	F	Ne
1.0	1.5	2.0	2.5	3.0	3.5	4.0	0
Na	Mg	Al	Si	P	S	Cl	Ar
0.9	1.2	1.5	1.8	2.1	2.5	3.0	0
K	Ca	Ga	Ge	As	Se	Br	Kr
0.8	1.2	1.6	1.8	2.0	2.4	2.8	0
Rb	Sr	In	Sn	Sb	Te	I	Xe
0.8	1.0	1.7	1.8	1.9	2.1	2.5	0
Cs	Ba	Tl	Pb	Bi	Po	At	Rn
0.7	1.9	1.8	1.8	1.9	2.0	2.2	0

Fr	Ra
0.7	1.9

Table 3.5: Electronegativity values of s and p-block elements as determined by Pauling (on F = 4.0 scale)

From this table it can be noted that the variation in the values of electronegativity is more pronounced among the non-metals.

(ii) **Allred and Rochow’s Scale**

Allred and Rochow proposed that the electronegativity of an element (say A) can be calculated by using the following equation:

$$(\chi_A)_{AR} = \frac{0.359 \times Z_{eff}}{r^2} + 0.744 \dots\dots\dots(3.13)$$

where $(\chi_A)_{AR}$ = electronegativity of the element A on Allred and Rochow’s scale, Z_{eff} = effective nuclear charge ($Z - \sigma$) at the periphery of the element A,

r is radius of the atom of element A in Å.

Putting the value of Z_{eff} , the equation can be rewritten as

$$(\chi_A)_{AR} = \frac{0.359 \times (Z - \sigma)}{r^2} + 0.744 \dots\dots\dots(3.14)$$

The electronegativity values obtained by this method agree closely to those obtained by Pauling’s approach. These values for the elements of first three periods are given below:

Table 3.6: Electronegativity values of s and p-block elements belonging to first three periods on Allred and Rochow’s scale

Group	1	2	13	14	15	16	17	18
	H 2.20							He 3.2
	Li	Be	B	C	N	O	F	NA

0.97	1.47	2.01	2.50	3.07	3.50	4.10	5.1
Na	Mg	Al	Si	P	S	Cl	Ar
1.01	1.23	1.47	1.74	2.06	2.44	2.83	3.3
K	Ca	Ca	Ge	As	Se	Br	Kr
0.91	1.04	1.82	2.02	2.20	2.48	2.74	3.1
Rb	Sr	In	Sn	Sb	Te	D	Xe
0.89	0.99	1.78	1.72	1.82	2.01	2.21	2.4
Cs	Ba	Tl	Pb	Bi	Po	At	Rn
0.86	0.97	1.44	1.55	1.67	1.76	1.90	-

According to this scale, the inert elements also possess electronegativity. As per the definition given by Pauling, this scale seems to be arbitrary but it has its own importance.

(iii) Mulliken's scale

It is based on the ionization energy and electron affinity of an atom of an element. According to Mulliken "the average of ionization energy (IE) and electron affinity (EA) of the atom of an element is a measure of its electronegativity".

Thus, the electronegativity = $\frac{I_E + E_A}{2}$ (3.15)

He proposed two relations for obtaining the electronegativity:

(a) When the energies are measured in electron volts (eV), then

$$\begin{aligned}\chi_A &= 0.374 \frac{(I_E + E_A)}{2} + 0.17 \\ &= 0.187 \frac{(I_E + E_A)}{2} + 0.17 \quad \text{.....(3.16)}\end{aligned}$$

(b) When the energies are expressed in kJ/mole, then

$$\chi_A = \frac{I_E + E_A}{540} \quad \text{.....(3.17)}$$

All these terms χ_A , IE and EA are for the atom A.

Factors affecting the magnitude of electronegativity

Various factors which affect the magnitude of the electronegativity of an element qualitatively are as follows:

(i) Atomic size

It has been observed that the smaller atom has greater tendency to attract the shared pair of electrons towards itself and hence has greater electronegativity. Thus electronegativity $\propto \frac{1}{\text{Atomic size}}$

(ii) Charge on the atom (or oxidation state of the element)

Higher the amount of positive charge on the atom of an element means higher positive oxidation state, smaller is the size and more is the electronegativity, i.e. electronegativity \propto positive oxidation state (or charge).

(iii) Effective nuclear charge (Z_{eff})

With the increase in the magnitude of Z_{eff} of an element, the electronegativity of that element also increases. This factor may effectively be used to explain the variation of electronegativity in a group or along a period. Thus, electronegativity $\propto Z_{\text{eff}}$.

(iv) Ionization energy and electron affinity

According to Mulliken's scale, electronegativity of an element depends on its ionization energy and electron affinity, Thus, the atoms of the elements which have higher values of ionization energy and electron affinity also have higher values of electronegativity, i.e. electronegativity \propto IE and EA.

(v) Type of hybridization of the central atom in a molecule

It has been observed that electronegativity of an atom having hybrid orbital with greater s-character is high because the electronic charge in hybrid orbitals of an atom in a molecule which has greater s-character remains closer to the nucleus of that atom. For example, the s-character in sp^3 , sp^2 , and sp hybrid orbitals of CH_4 , C_2H_4 and C_2H_2 is 25%, 33% and 50%, respectively. Accordingly, the s-character of hybrid orbitals gives more electronegativity to C atom. Hence the electronegativity of carbon atom in these molecules is in the following increasing order:

**Periodic trends of electronegativity****(i) Variation in the groups of main group elements**

On going down a group of main group elements, the electronegativity values go on decreasing due to increasing atomic size and decreasing Z_{eff} of the elements. At the same time, the electropositive character of the elements also increases causing a reduction in electronegativity values of the elements as well as their ionization energies and electron affinities.

(ii) **Variation along a period**

On moving from left to right across a period of main group elements i.e. from alkali metals to halogens, electronegativity values increase with increasing atomic number. This happens because Z_{eff} increases, electropositive character decreases, atomic size of the elements also decreases thereby increasing electronegativity. Ionization energy and electron affinity, in general, also increase along a period.

Applications of Electronegativity

On the basis of electronegativity, certain facts in chemistry can be explained which are given below:

(i) **To predict the nature of bonds**

With the help of the electronegativity difference $\chi_B - \chi_A$ (where $\chi_B < \chi_A$) between two atoms A and B, we can predict whether A-B bond would be non-polar covalent bond, polar covalent bond or ionic bond. If $\chi_B - \chi_A = 0$, i.e. either the atoms A and B are same or if different have almost similar electronegativity values, the bond is non-polar covalent bond. When $\chi_B - \chi_A$ is relatively small, e.g. O-H, Cl-H etc. the bond formed between the atoms is polar covalent bond. When $\chi_B - \chi_A$ is very large, complete transfer of an electron from atom A to atom B takes place and the resulting bond between the atoms is purely ionic.

The percent ionic character present in the polar covalent bond can be calculated. For a polar covalent molecule $A^{\delta+}-B^{\delta-}$, Pauling has correlated the percent ionic character of a covalent bond with the electronegativity difference between the combining atoms as is given below:

$(\chi_B - \chi_A)$	0.6	1.0	1.7	2	3
Percent ionic character	9	22	51	63	91

He used the equation:

$$\text{Amount of ionic character in A-B bond} = [1 - e^{0.25(\chi_B - \chi_A)}] \% \quad \dots\dots\dots(3.18)$$

Further, Hannay and Smith gave the following equation to calculate the ionic character.

$$\text{Ionic Character in A - B bond} = [16 (\chi_B - \chi_A) + 3.5 (\chi_B - \chi_A)^2] \% (\chi_B > \chi_A) \dots (3.19)$$

(ii) **To calculate the bond length**

In a heterodiatomic molecule of AB type, the bond length d_{A-B} can be calculated provided the molecule has ionic character and the values of atomic radii r_A and r_B as well as the electronegativities χ_A and χ_B are known. This can be done by using the Schoemaker and Stevenson equation, viz.

$$d_{A-B} = r_A + r_B - 9 (\chi_B - \chi_A) (\chi_B > \chi_A) \dots (3.20)$$

(iii) **To predict the trends in acid-base character**

(a) The acidic character of the oxides has been found to increase from left to right along a period because of decreasing $\chi_O - \chi_B$ values (χ_O and χ_B are electronegativities of oxygen and other atom), e.g.

Oxide	Na ₂ O	MgO	Al ₂ O ₃	SiO ₂	P ₄ O ₁₀	SO ₂	Cl ₂ O ₇
χ_B	0.9	1.2	1.5	1.8	2.1	2.5	3
$\chi_O - \chi_B$	2.6	2.3	2.0	1.7	1.4	1.0	0.5
Nature	strongly basic	basic	amphoteric	weakly acidic	acidic	strongly acidic	strongly acidic

(b) The acidic character of hydrides of the elements of the same period goes on increasing from left to right across a period. For example, the acidic nature of CH₄, NH₃, H₂O and HF molecules, the hydrides of the elements of second period, increases in the order: CH₄, < NH₃, < H₂O < HF because of the increasing electronegativity of the central atom and increasing electronegativity difference between the central atom and hydrogen atom i.e.

$$\chi_{\text{central atom}} - \chi_H$$

(c) The acidic character of oxyacids of the elements of the same group and in the same oxidation state, e.g. HClO₄, HBrO₄ and HIO₄ decreases as the electronegativity of central halogen atom decreases as we move down the group from Cl to I ($\chi_{Cl} = 3.0$ and $\chi_I = 2.5$ on Pauling's scale).

(iv) **To explain the diagonal relationship**

It has been found that the elements of second period of the periodic table show similarities in properties with the elements lying diagonally opposite on right hand side in the third period

This property is called diagonal relationship. These elements are shown below:

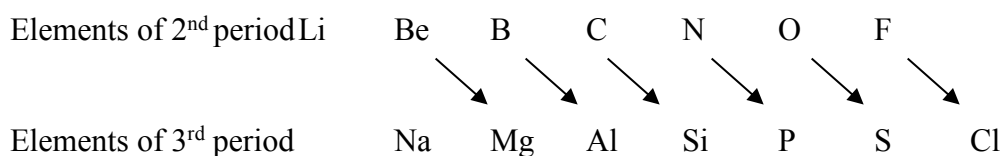

This similarity in properties can be explained by various facts and one of them is the concept of electronegativity. The electronegativities of the diagonally opposite elements are almost the same and hence show similar properties.

3.4 TRENDS IN PERIODIC TABLE

All the periodic properties, i.e. atomic and ionic radii, ionization energy, electron affinity and electronegativity show variation along the period and down a group. The trends for various properties have been discussed in the respective sections.

3.5 SUMMARY

the summary of this unit is :

- This unit contains a concise and comprehensive discussion of various periodic properties such as atomic and ionic radii, ionization energy, electron affinity and electronegativity, factors affecting these properties, periodic trends (or variation) of the properties, the methods of their determinations and their applications wherever necessary and available.
- The periodic properties are the basis of the physical and chemical properties of the elements which can be predicted keeping in view the above property.

TERMINAL QUESTIONS

- i) Arrange the following ions in the increasing of their size
 - a. Na^+ , Mg^{2+} , Al^{3+} , F^- , O^{2-} , N^{3-}
 - b. C^{4-} , N^{3-} , O^{2-} , F^-
- ii) Which atom or ion in the following pairs has smaller size and why ?
 - a. Na, Na^+
 - b. Be, Mg

- c. $\text{Fe}^{2+}, \text{Fe}^{3+}$
- iii) Explain giving appropriate reasons:
- a. The Cl^- ion is larger in size than Cl atom.
- b. The atomic radius decreases with the increasing atomic numbers in a period.
- iv) Arrange the following in the decreasing order of their ionization energy: Be, B, N, O and F.
- v) Arrange the Be, B, N, O and F in the increasing order of their electron affinities.
- vi) EA values of the halogens are the highest in each period. Explain.
- vii) The noble gases have very high values of ionization energy but their electron affinity values are almost zero. Why?
- viii) Which of the following elements has the highest values of electron affinity and why?
- a. Na, Cl, Si, Ar
- b. (i) $1s^2, 2s^2, 2p^1$ (ii) $1s^2, 2s^2, 2p^6, 3s^1$ (iii) $1s^2, 2s^2, 2p^5$ (iv) $1s^2, 2s^2, 2p^3$
- ix) Distinguish between electron affinity and electronegativity.
- x) Which element among the following has the highest value of electronegativity and the highest value of electron affinity? F, Cl, O, Br, and I.
- xi) Which one of the following oxides is basic, amphoteric, and acidic in nature?
- a. MgO
- b. Al_2O_3
- c. P_4O_{10}
- xii) How does electron affinity depend on effective nuclear charge?

3.5 REFERENCES

1. Principles of Inorganic Chemistry: B. R. Puri, L.R. Sharma & K. C. Kalia, Milestone Publishers and Distributors, Daryaganj, Delhi (2013).
2. Selected topics in Inorganic Chemistry: W.U. Malik, G.D. Tuli & R.D. Madan, S. Chand & Co. Ltd., New Delhi (1993).
3. Comprehensive Inorganic chemistry: Sulekh Chandra, New Age International (Pvt.) Ltd., New Delhi (2004).
4. The Nature of the Chemical Bond: Linus Pauling, 3rd Edn., Cornell University Press, New York (1960).
5. A Simple Guide to Modern Valency Theory: G.I. Brown, Revised Edn., Longmans Green,

London (1967).

6. Advanced Inorganic Chemistry: Satya Prakash, G.D. Tuli, S.K. Basu and R.d. Madan, Vol. I, 7th Edn., S. Chand & Co. Ltd, New Delhi (1998).

7. Shriver and Atkins' Inorganic Chemistry: Peter Atkins *et. al.*, 5th Edn., Oxford University Press, New York (2010).

UNIT 4: CHEMICAL BONDING

CONTENTS:

4.1 Objectives

4.2 Introduction

4.3 Covalent bond

4.3.1 Valence bond theory and its limitation

4.3.2 Directional characteristics of covalent bond

4.3.3 Sigma and pi covalent bond

4.4 Hybridization of atomic orbitals

4.4.1 Types of hybridization

4.4.2 Shape of simple inorganic molecules and ions

4.5 Valence shell electron pair repulsion theory (VSEPR) theory

4.6 Molecular Orbital theory

4.6.1 Homonuclear diatomic molecules

4.6.2 Heteronuclear (CO and MO) diatomic molecules

4.7 Multicenter bonding in electron deficient molecules

4.8 Bond strength

4.8.1 Bond energy

4.8.2 Measurement of bond energy

4.9. Percent ionic character

4.10 Summary

4.11 Terminal Question

4.12 Answers

4.13 References

4.1 INTRODUCTION

The atoms are said to combine together because of the following two main reasons:

(i) Concept of lowering of energy

It has been observed that the aggregate (or the molecules) are lower in energy than the individual atoms from which they have been formed. This means when the individual atoms combine to form molecules through a bond, the potential energy of the combining atoms decreases and the resulting molecules are more stable than the free atoms. This energy difference between the free atoms and bonded atoms (or molecules) is generally 40kJ mol^{-1} or more. It follows from this that the process of bond formation between the atoms decreases the energy of the molecule formed from these atoms and forms a system of lower energy and greater stability.

(ii) Electronic theory of valence (the octet rule)

The atoms of the noble gases-helium to radon- do not, except a few cases, react with any other atoms to form the compounds and also they do not react with themselves. Hence they stay in atomic form. These atoms are said to have low energy and cannot be further lowered by forming compounds. This low energy of noble gas atoms is associated with their outer shell electronic configuration, i.e. the stable arrangement of eight electrons (called octet). It has also been established that the two electrons in case of helium atom (called doublet) is as stable as an octet present in other noble gas atoms. The chemical stability of the octet of noble gases led chemists to assume that when atoms of other elements combine to form a molecule, the electrons in their outer shells are arranged between themselves in such a way that they achieve a stable octet of electrons (noble gas configuration) and thus a chemical bond is established between the atoms.

This tendency of the atoms to attain the noble gas configuration of eight electrons in their outer shell is known as octet rule or rule of eight and when the atoms attain the helium configuration, it is called doublet rule or rule of two. This octet rule was later called “**Electronic Theory of Valence**”.

It may be noted here that in the formation of a chemical bond, atoms interact with each other by losing, gaining or sharing of electrons so as to acquire a stable outer shell configuration of eight electrons. This means, an atom with less than eight electrons in the

outer shell is chemically active and has a tendency to combine with other atoms. Accordingly, three different types of bonds may exist in the molecules/aggregates.

4.2 OBJECTIVES

The objective of writing the text of this unit is :

- Under this unit you will be understand various facts regarding the driving force that makes the isolated atoms to combine to form the polyatomic molecules or ions as well as to find the answers of certain interesting questions.
- In this unit you will be gaining about the valence bond theory and its limitation, directional characteristics of covalent bond and known about the Sigma and pi covalent bond.
- Under this unit you enhance the knowledge in the concepts of the different type hybridization of atomic orbitals and shape of simple inorganic molecules and ions.
- In this unit you will be able to about the valence shell electron pair repulsion theory (VSEPR) theory and the molecular orbital theory for the homonuclear diatomic molecules and heteronuclear (CO and MO) diatomic molecules.
- And end of the this unit you able to known multi-center bonding in electron deficient molecules, Bond strength, Bond energy, Measurement of bond energy and Percent ionic character.

4.3 COVALENT BOND

A covalent bond is formed between the two combining atoms, generally of the electronegative non-metallic elements by the mutual sharing of one or more electron pairs (from their valence shell). Each of the two combining atoms attains stable noble gas electronic configuration, thereby enhancing the stability of the molecule. If one electron pair is shared between the two atoms, each atom contributes one electron towards the electron pair forming the bond. This electron pair is responsible for the stability of both the atoms. A covalent bond is denoted by the solid line (-) between the atoms. Depending on the number of shared electron pairs i.e. one, two, three etc. electron pairs between the combining atoms, the bond is known as a single, double, triple etc. covalent bond. For example,

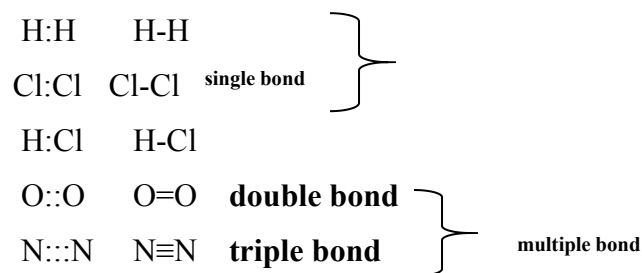

In the molecules, the bond strength and bond length has been found in the following order:

Bond strength: triple bond > double bond > single bond

Bond length: triple bond < double bond < single bond

It may be noted that the covalent bond formation between multielectron atoms involves only the valence shell electrons that too, the unpaired electrons. Thus O-atom has two unpaired electrons in its valence shell and N-atom has three unpaired electrons thereby forming two and three bonds with themselves or other atoms.

Polar and non-polar covalent bond

In the examples given above, most of the bonds *viz.* single, double and triple covalent bonds, have been shown to be formed between the like atoms such as H-H, Cl-Cl, O=O and N≡N in H₂, Cl₂, O₂ and N₂, respectively. The bonded atoms in these molecules attract the bonding or shared pair of electrons by equal forces towards themselves due to equal electronegativity of the atoms. Hence the bonding pair of electron lies at the mid point of the internuclear distance (or bond distance). This type of bond is known as the non-polar covalent bond.

But if the covalent bond is formed between two unlike atoms of different elements, e.g. HCl, H₂O, NH₃ etc., the shared pair of electrons will not be equally attracted by the bonded atoms due to electronegativity difference. It shifts towards more electronegative atom and hence moves away from less electronegative atom. This develops small negative charge on more electronegative atom and equal positive charge on less electronegative atom. Such a molecule is called a polar molecule (this is different from ionic bond) and the bond present in such molecules is known as polar covalent bond. For example,

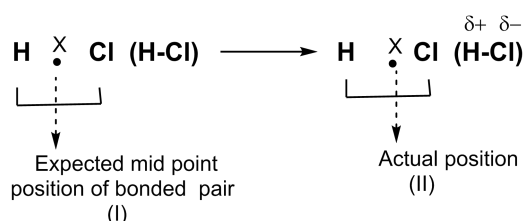

4.3.1. Valence Bond Theory (VBT) and its limitations:

This theory was put forward by Heitler and London in 1927 to explain the nature of covalent bond. They gave a theoretical treatment of the formation of the bond in H₂ molecule and the energy changes taking place therein. Later, it was extended by Pauling and Slater in 1931 to account for the directional characteristics of the covalent bond.

The main points called the postulates of this theory are given below:

- (i) The atoms involved in the bond formation maintain their individuality (identity) even after the bond is formed i.e. in the molecule.
- (ii) The bond is formed due to the overlapping of half filled atomic orbitals (or the interaction of electron waves) belonging to the valence shell of the combining atoms as these approach each other. Thus the spins of the two electrons get mutually neutralized. The electrons in the orbitals of inner shells remain undisturbed.
- (iii) The filled orbitals (i.e. containing two electrons) of the valence shell do not take part in the bond formation. However, if the paired electrons can be unpaired without using much energy, they are first unpaired by promoting to the orbitals of slightly higher energy and then can take part in bonding. For example, N can form NCl₃ only retaining a lone pair while P can form both PCl₃ and PCl₅.
- (iv) The electrons forming the bond undergo exchange between the atoms and thus stabilize the bond.
- (v) The strength of the covalent bond depends on the extent to which the two atomic orbital overlap in space.

This theory is based on two main theorems which are:

(a) If $\Psi_A(1)$ and $\Psi_B(2)$ are the wave functions of the orbitals containing electrons in two isolated independent atoms A and B with energies E_A and E_B , respectively then the total wave function Ψ of the system can be given as a product of wave functions of two atoms, i.e.

$$\Psi = \Psi_A(1) \cdot \Psi_B(2) \quad \dots\dots(4.1)$$

and the energy of the system by

$$E = E_A + E_B \quad \dots\dots(4.2)$$

Where (1) and (2) indicate two electrons belonging to atoms A and B.

(b) If a system can be represented by a number of wave functions such as $\Psi_1, \Psi_2, \Psi_3, \dots\dots$, then the true wave function Ψ can be obtained by the process of linear combination of all these wave functions as:

$$\Psi = N(C_1\Psi_1 + C_2\Psi_2 + C_3\Psi_3 + \dots) \quad \dots(4.3)$$

Where N is normalization constant and $C_1, C_2, C_3 \dots$ are the coefficients indicating the weight of each of Ψ s. They are so adjusted as to give a state of lowest energy. The squares of the coefficients may be taken as the measure of the weight of each wave function to total wave function.

The valance bond theory was first applied to the formation of H_2 molecule. If the two H-atoms, *viz.* H_A and H_B are infinitely apart from each other, there is no interaction at all but if these are brought close together, $H_A - H_B$ covalent bond is formed and the energy of the system is decreased. Now if the orbitals of the two H-atoms are represented in terms of wave functions Ψ_A and Ψ_B , then the wave function for the system $H_A.H_B$ can be written as

$$\Psi = \Psi_A(1). \Psi_B(2) \quad \dots(4.1 \text{ as given above})$$

Where electrons belonging to H_A and H_B are 1 and 2.

But once the bond is formed, the electrons 1 and 2 have equal freedom to get associated with either of the H-atoms. Thus due to the exchange of electrons between H-atoms, two possible covalent structures of H_2 molecule may shown as $H_A(1).H_B(2)$ and $H_A(2).H_B(1)$. The wave functions of these structures are $\Psi_A(1). \Psi_B(2)$ and $\Psi_A(2). \Psi_B(1)$ respectively. Now the true wave function for H_2 molecules can be obtained by linear combination of the wave functions for the two covalent structures. This can be done in two ways:

(i) When the combination of these wave functions takes place in a symmetric way, i.e. by addition process, symmetric wave function Ψ_s is obtained:

$$\Psi_s = \Psi_A(1). \Psi_B(2) + \Psi_A(2). \Psi_B(1) \quad \dots(4.4)$$

This is also known as covalent wave function, Ψ_{cov} .

(ii) When the combination of the above wave functions takes place in a asymmetric way i.e. by subtraction process, asymmetric wave function, Ψ_a , is obtained:

$$\Psi_a = \Psi_A(1). \Psi_B(2) - \Psi_A(2). \Psi_B(1) \quad \dots(4.5)$$

The value of Ψ_s does not change by exchange of electrons 1 and 2 but that of Ψ_a changes in this process. The two situations are presented graphically as follows: (**Fig 4.1**)

The curve s is for addition process and curve a is for subtraction process of the wave functions. The calculated value of r_0 for the minimum energy state i.e. the bonding state is 87 pm against the experimental value of 74 pm.

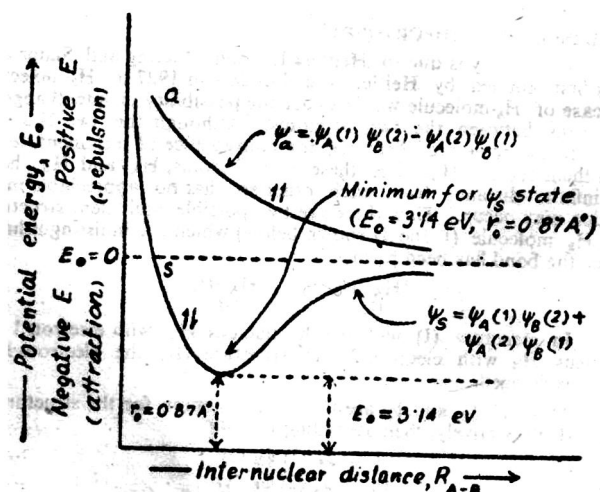

Fig 4.1

Pauling has suggested that the bond between two H-atoms in H_2 molecule is not absolutely covalent, it rather has partial ionic character. He proposed two ionic structures for H_2 molecule in which both the electrons 1 and 2 are either attached to H_A or H_B as given below,



If the above wave functions for these structures are $\Psi_{(1)}$ and $\Psi_{(2)}$, then

$$\Psi_{(1)} = \Psi_A(1). \Psi_A(2) \quad \dots(4.6)$$

And $\Psi_{(2)} = \Psi_B(1). \Psi_B(2) \quad \dots(4.7)$

The consideration of ionic structures as given above of H_2 molecule converts the equation 4.4 to

$$\Psi_S = [\Psi_A(1). \Psi_B(2) + \Psi_A(2). \Psi_B(1)] + \lambda [\Psi_{(1)} + \Psi_{(2)}]$$

or $\Psi_S = [\Psi_A(1). \Psi_B(2) + \Psi_A(2). \Psi_B(1)] + \lambda [\Psi_A(1). \Psi_A(2) + \Psi_B(1). \Psi_B(2)] \quad \dots(4.8)$

or $\Psi_S = \Psi_{cov.} + \Psi_{ionic} \quad \dots(4.9)$

the coefficient λ is used in equation 4.8 is a measure of the degree to which the ionic forms contribute to the bonding. Thus three important contributions to covalent bonding may be summarized as follows:

- (i) Delocalization of electrons over two or more nuclei
- (ii) Mutual screening
- (iii) Partial ionic character.

Limitations of Valence Bond theory:

(i) The formation of coordinate covalent bond (also known as dative bond) cannot be explained on the basis of this theory because according to this theory a covalent bond is formed as a result of overlapping of half filled orbitals of the combining atoms and the paired orbitals of the atoms do not take part in normal covalent bond formation.

ii) The odd electron bond formation between the atoms cannot be explained by this theory because a covalent bond is an electron pair bond means two electrons are required for a bond.

iii) This theory is unable to explain the paramagnetic behaviour of oxygen molecule because paramagnetism is a property caused by the presence of unpaired electrons and in an oxygen molecule, according to VBT, two electron pair bonds are present between the oxygen atoms and hence it should be diamagnetic.

iv) In some molecules, the properties like bond length and bond angles could not be explained by assuming simple overlapping of atomic orbitals of the atoms.

4.3.2 Directional characteristics of covalent bond:

The covalent bonds are directed in space. This fact is evidenced by the stereoisomerism and a wide variety of geometrical shapes shown by the covalent compounds. It is also possible to measure the actual bond angles between covalent bonds in the molecules because of the directional nature of bonds. An important fact about the covalent bonds is that these are formed by the overlapping of pure as well as hybridised atomic orbitals. All these atomic orbitals except the pure s-orbitals, are oriented in the particular directions which determine the direction of covalent bonds i.e. the direction in which the overlapping orbitals have the greatest electron density. From this discussion we can conclude that it is the directional nature of p, d and f orbitals which accounts for the directional nature of the covalent bond. For example, the three p-orbitals are directed along the three axes x,y and z and the bonds formed by their overlapping are also directed towards the three axes. Though the s-orbitals are spherically symmetrical around the nucleus, their overlapping along the molecular axis gives a bond in that direction.

Let us discuss the modes of overlapping of pure and some of the hybridised atomic orbitals:

(i) s-s overlapping

This type of overlapping occurs between the s-orbitals of the combining atoms thereby giving the s-s covalent bond. This type of overlapping always occurs in the direction of molecular or internuclear axis.

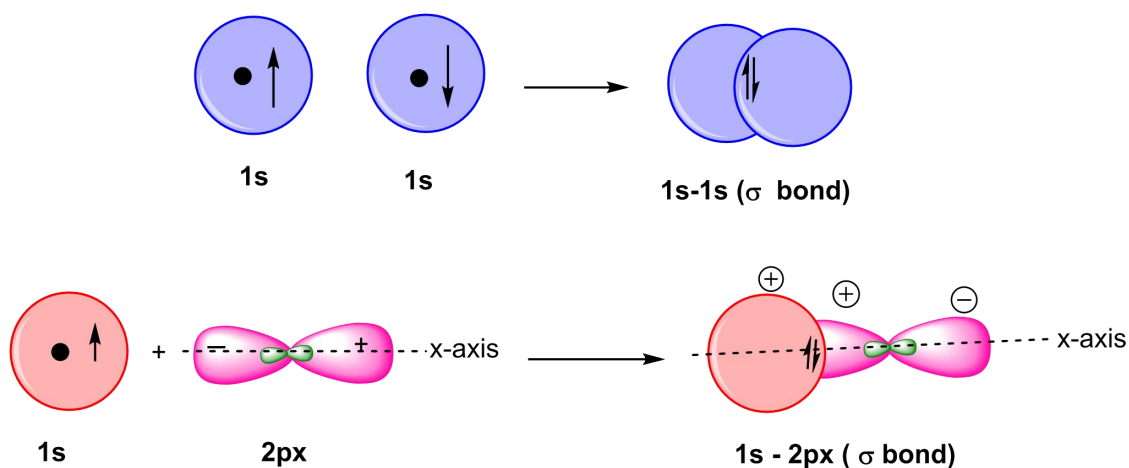

Fig 4.2 overlapping of two s-orbitals along molecular axis

(ii) **s-p overlapping**

The overlapping taking place between the s-orbital of one atom and p-orbital of another atom is called s-p overlapping. The resulting bond is the s-p covalent bond formed in the direction of the orientation of p-orbital taking part in overlapping (fig. 4.2).

(iii) **p-p overlapping**

When the p-orbital of one atom overlaps with the p-orbital of another atom, this process is called p-p overlapping and the bond so formed is known as p-p covalent bond. The necessary condition for this type of overlapping is that the p-orbitals must be of the same type, i.e. p_x and p_x , p_y and p_y and p_z and p_z . The p_x-p_y or p_x-p_z type of overlapping does not occur (fig 4.3).

If an atom possesses two or three half filled orbitals, they can simultaneously overlap with another similar atom (or other atoms as well) thereby forming multiple bonds (both σ and π), for example oxygen molecule. Similarly bonding in N_2 can be explained.

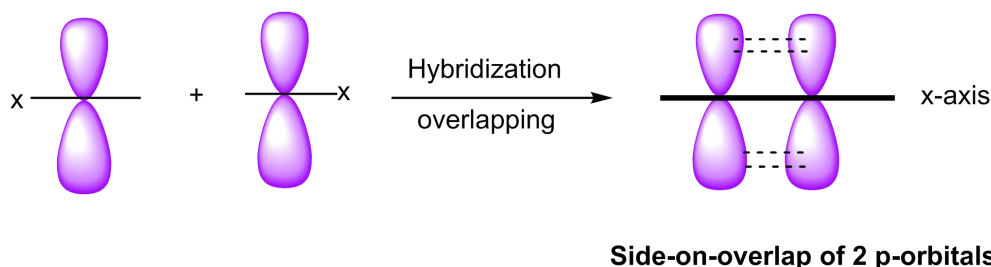

Fig 4.3 overlapping of orbitals forming σ and π bonds

Overlapping of the hybrid orbitals with pure atomic orbitals

The s and p-orbitals may overlap with hybrid orbitals to give the directional covalent bonds such as s-sp (BeH_2), s-sp² (BH_3 , C_2H_4), s-sp³ (CH_4 and higher alkanes), p-sp (BeCl_2), p-sp² (BCl_3), p-sp³ (CCl_4), p-sp³d (PCl_5), p-sp³d² (SF_6) p-sp³d³ (IF_7) etc. bonds in the directions of hybrid orbitals. d and f - orbitals in non-metallic elements (which mostly form covalent compounds) do not generally take part in overlapping as such to form covalent bonds but d-orbitals may participate in hybridisation, e.g. in PCl_5 , SF_6 , higher interhalogens etc. and form covalent bonds by the overlapping of hybrid orbitals with atomic orbitals in the directions of hybrid orbitals.

(v) Overlapping of the hybrid orbitals among themselves. This type of overlapping mainly occurs among the organic compounds, e.g. sp-sp (C_2H_2), sp²-sp² (C_2H_4), sp³-sp³ (C_2H_6) etc. Here only the overlapping of hybrid orbitals with themselves has been given.

4.3.3 Sigma (σ) and pi (π) covalent bonds:

σ Covalent bonds

The covalent bond formed between the two atoms by axial or head on overlapping of pure or hybrid atomic orbitals belonging to valence shells of the atoms is called a σ bond. Pure s-orbitals of the atoms on overlapping with s or p atomic orbitals or hybrid orbitals of other atoms always form σ bonds. Pure p-orbitals of the atom when overlap with s and p-orbitals (of the same symmetry) or hybrid orbitals of other atoms also form σ bonds. d and f-orbitals by themselves seldom take part in σ bond formation through the d-orbitals are sometimes involved in hybridisation and thus form a σ bonds, e.g. PCl_5 , SF_6 , IF_7 etc. The overlapping of hybrid orbitals between two atoms always gives σ bond.

(i) Pure atomic orbital overlapping

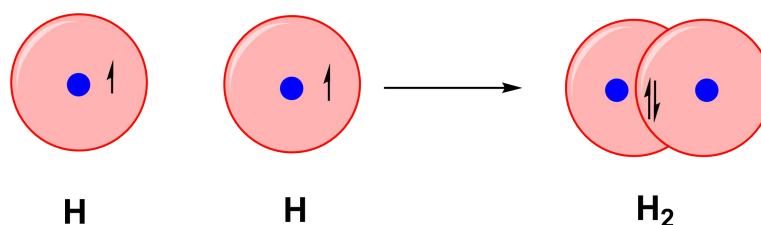

Fig 4.4 formation of σ bond by atomic orbitals

(ii) Hybrid atomic orbital – hybrid atomic orbital overlapping

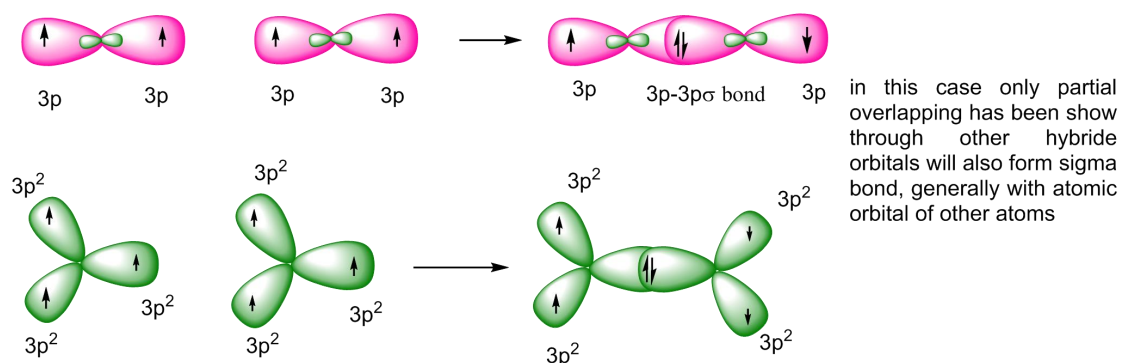

Fig 4.5 formation of σ bond by hybrid orbitals

In this case only partial overlapping has been shown though other hybrid orbitals will also form σ bonds, generally with atomic orbitals of other atoms.

Similarly $sp^3-sp^3\sigma$ bond formation may also be shown.

π (pi) Covalent bond

A covalent bond formed between two atoms by side to side or lateral (perpendicular to the molecular axis) overlapping of only p-atomic orbitals or sometimes p and d- orbitals belonging to the valence shell of the atoms is called a π bond. If in a molecule, a particular atom uses one of its p-orbitals for σ bond formation then rest of the two p-orbitals are used to form the π bonds by lateral overlapping. For example, if x axis is taken as the molecular axis, then π bond is formed by $p_y - p_y$ or p_z-p_z overlapping as happens in the oxygen and nitrogen molecules.

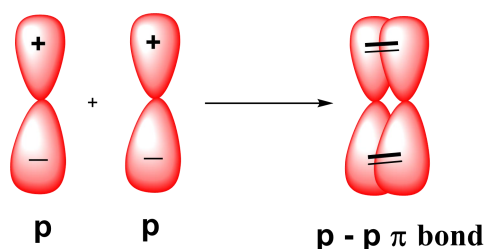

Fig 4.6 formation of π bond by lateral overlapping of atomic orbitals

For σ and π bonds, the following points are important:

- (i) A σ bond is formed by axial overlapping of either pure or hybrid atomic orbitals of the two combining atoms while a π bond results from the lateral overlapping of the pure atomic orbitals.

- (ii) A σ bond is stronger than a π bond due to greater extent of overlapping of orbitals along the inter nuclear axis than in lateral overlapping.
- (iii) A σ bonds determine the direction of the covalent bond and bond length, π bonds have no effect on the direction of the bond. However, their presence shortens the bond length.
- (iv) There is free rotation of the atoms about a σ bond because the electron cloud overlaps symmetrically along the internuclear axis while this is not possible about a π bond because the electron clouds overlap above and below the plane of the atoms.
- (v) A σ bond has its free existence between any two atoms in a molecule while π bond is formed between the atoms only when σ bond already exists.

The shapes of covalent molecules and ions can be explained by employing (a) the concept of hybridisation and (b) VSEPR Theory.

4.4 HYBRIDISATION OF ATOMIC ORBITALS

It is the theoretical model used to explain the covalent bonding in the molecules and is applied to an atom in the molecule. To explain the anomaly of expected mode of bonding (according to VBT) shown by Be, B and C in their compounds where these elements should be zero-valent, mono-valent and bivalent due to the presence of 0,1 and 2 unpaired electrons in their valence shells and the observed bonding exhibited by them, i.e. these are bivalent, trivalent and tetra-valent due to the availability of 2,3 and 4 unpaired electrons in their valence shells in those compounds, a hypothetical concept of hybridisation was put forward. According to this concept, before the bonding occurs in the compounds of Be, B and C, one of the 2s electrons gets promoted to the vacant 2p orbital due to the energy available from the heat of reaction when covalent bonds are formed or perhaps due to the field created by the approaching atoms, thereby making 2,3 and 4 unpaired electrons available in the valence shell of the atoms of these elements.

These orbitals having unpaired electrons then mix up together or redistribute their energy to give rise a new set of orbitals equivalent in energy, identical in shape and equal to the number of atomic orbitals mixed together. This process is known as hybridisation, the atomic orbitals are said to be hybridised and the new orbitals formed are called the hybrid orbitals. The hybrid orbitals so formed then overlap with the half filled orbitals of the approaching atoms and form covalent bonds.

Salient features (or the Rules) of hybridisation

- i) The atomic orbitals belonging to the valence shell of the central atom/ion of a molecule/ion with almost similar energies mix up together or hybridise to give the hybrid orbitals. But the atomic orbitals of the central atom participating in the π bond formation are excluded from the hybridisation process.
- ii) The number of hybrid orbitals produced is equal to the number of atomic orbitals undergoing hybridisation. The hybrid orbitals like pure atomic orbitals can accommodate a maximum of two electrons of opposite spins.
- iii) If required, electron (s) may be promoted from an orbital in ground state of the central atom to the next empty higher energy orbital provided the value of n does not change as happens in the central atom of BeCl_2 , BCl_3 , CH_4 , PCl_5 , SF_6 etc.
- iv) Most of the hybrid orbitals are equivalent in energy, shape and size but may not be identical. They differ from one another in their orientation in space.
- v) From the type of hybridisation, the geometry and bond angles of a molecule can be predicted.
- vi) In a few cases empty atomic orbitals or those with lone pairs of electrons (i.e. filled atomic orbitals) are also involved in the hybridisation process but in such cases normal covalent bond is not formed rather this process leads to the formation of coordinate covalent bond. Sometimes these filled hybrid orbitals do not form the bonds and the electron pair remains as lone pair on central atom.
- vii) The hybrid orbitals are involved in the σ bond formation only and π bond is not formed by them at all.

4.4.1. Types of hybridization: Following are the important types of hybridisation. The central atom in a given molecule/ion can undergo any of the following possible hybridisations.

(i) Sp hybridization:

When one s and one p (oriented along molecular axis) atomic orbitals belonging to the valence shell of the central atom in a given molecule/ion mix up together to give rise two hybrid orbitals, the process is known as sp hybridisation and the new orbitals formed are called sp hybrid orbitals. This process can be shown diagrammatically as follows:

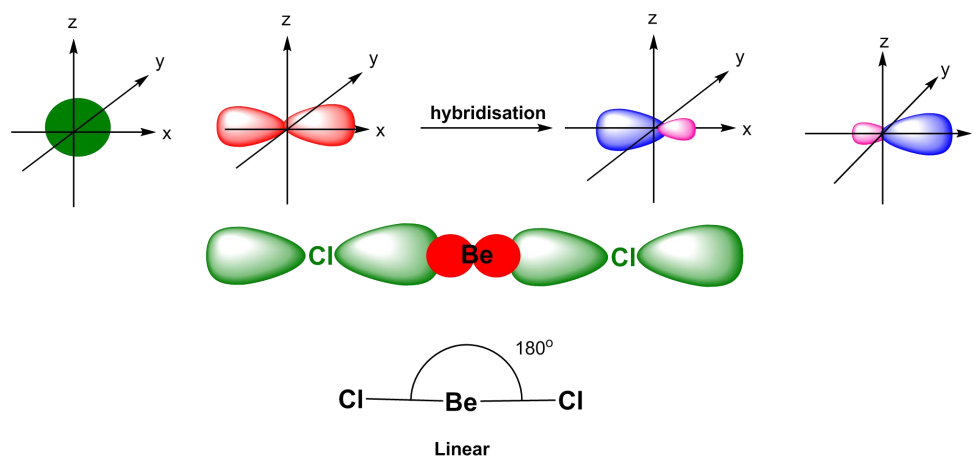

Fig 4.7 Formation of two collinear sp hybrid orbitals from the mixing of one s and one p atomic orbitals (sp hybridisation)

Characteristics:

- i) These hybrid orbitals are equivalent in energy, shape (oval shaped) and are oriented in the opposite directions at an angle of 180° from each other, leading to linear geometry.
- ii) Each hybrid orbital has one large lobe and one small lobe. The larger lobe takes part in overlapping process.
- iii) These hybrid orbitals possess 50% character of s -orbital (spherical) and 50% that of p -orbital (pear shaped) and hence are oval shaped.

Examples: BeX_2 ($X=\text{H}, \text{F}, \text{Cl}$). Let us take BeF_2 molecule for illustration.

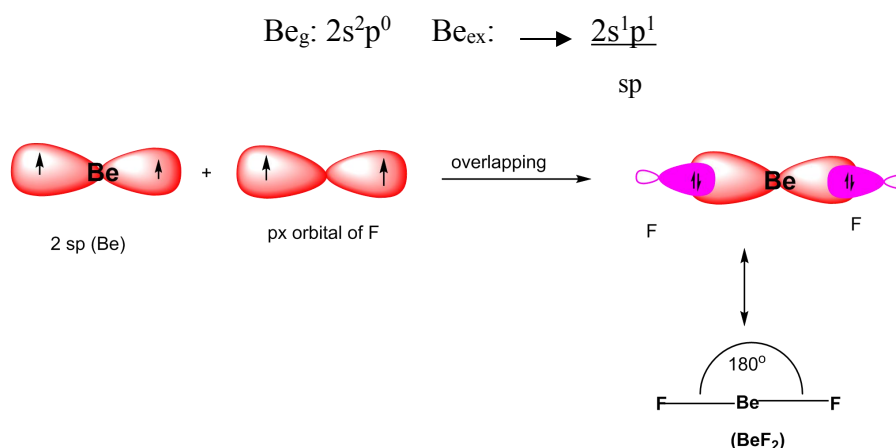

Fig 4.8 formation of two σ covalent bonds by the overlapping of sp -hybrid orbitals of Be and $2p$ -orbitals of F -atoms

(ii) sp^2 hybridisation:

On mixing together one s and any two p -orbitals belonging to the valence shell of the central atom of a given molecule/ion, a set of three hybrid orbitals is obtained. This process is

known as sp^2 hybridisation and the new orbitals formed are termed as sp^2 hybrid orbitals. The process can be shown as given below:

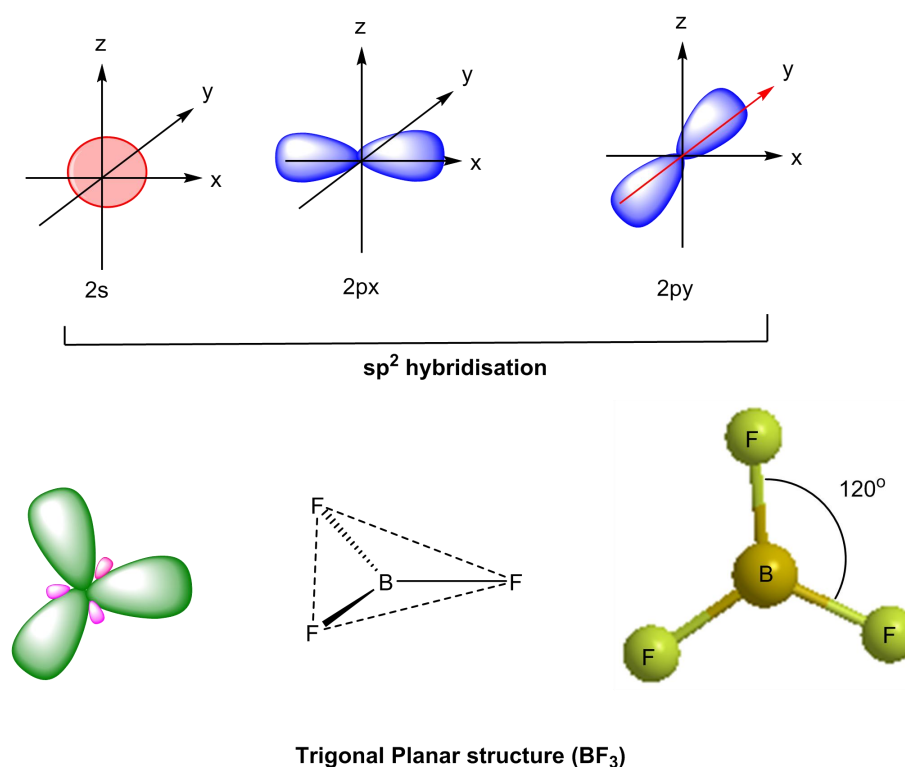
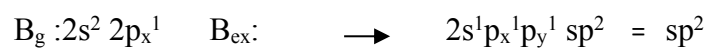

Fig 4.9 Formation of three trigonal planar sp^2 hybrid orbitals from the mixing of one s and two p atomic orbitals (sp^2 hybridisation).

Characteristics:

- i) The sp^2 hybrid orbitals are equivalent in energy and shape and are oriented towards the corners of an equilateral triangle, hence inclined at an angle of 120° with one another, leading to trigonal planar geometry.
- ii) They all lie in one plane (i.e. planar).
- iii) They possess 33% s - character and 66% p - character and therefore are less oval than sp - hybrid orbitals.

Examples: BX_3 ($X=H, F, Cl$) Let us take BF_3 molecule for discussion.



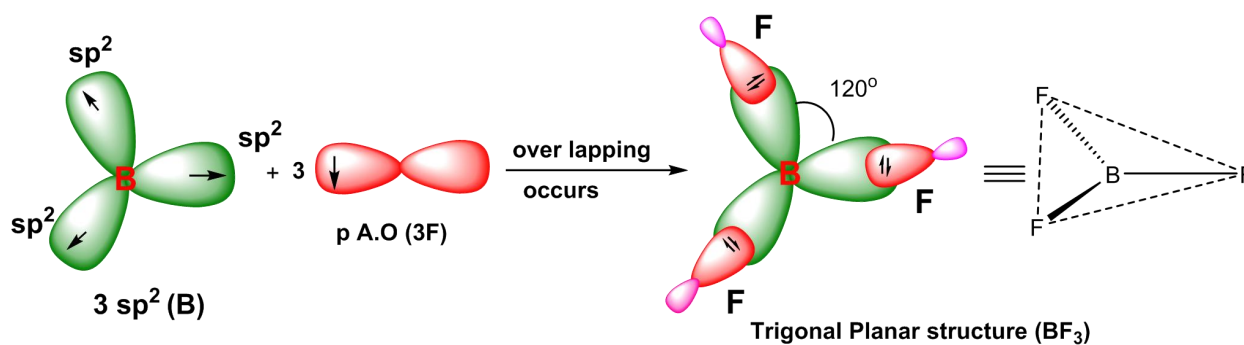

Fig 4.10 formation of three σ covalent bonds by the overlapping of sp^2 hybrid orbitals of B-atoms and $2p$ -orbitals of $3F$ -atoms

(iii) sp^3 hybridisation:

In this hybridisation, one s and three p-atomic orbitals belonging to the valence shell of the central atom of a given molecule/ion mix up together and form a set of four hybrid orbitals. This mixing process is known as sp^3 hybridisation and the new orbitals formed are called sp^3 hybrid orbitals. This process has been shown below:

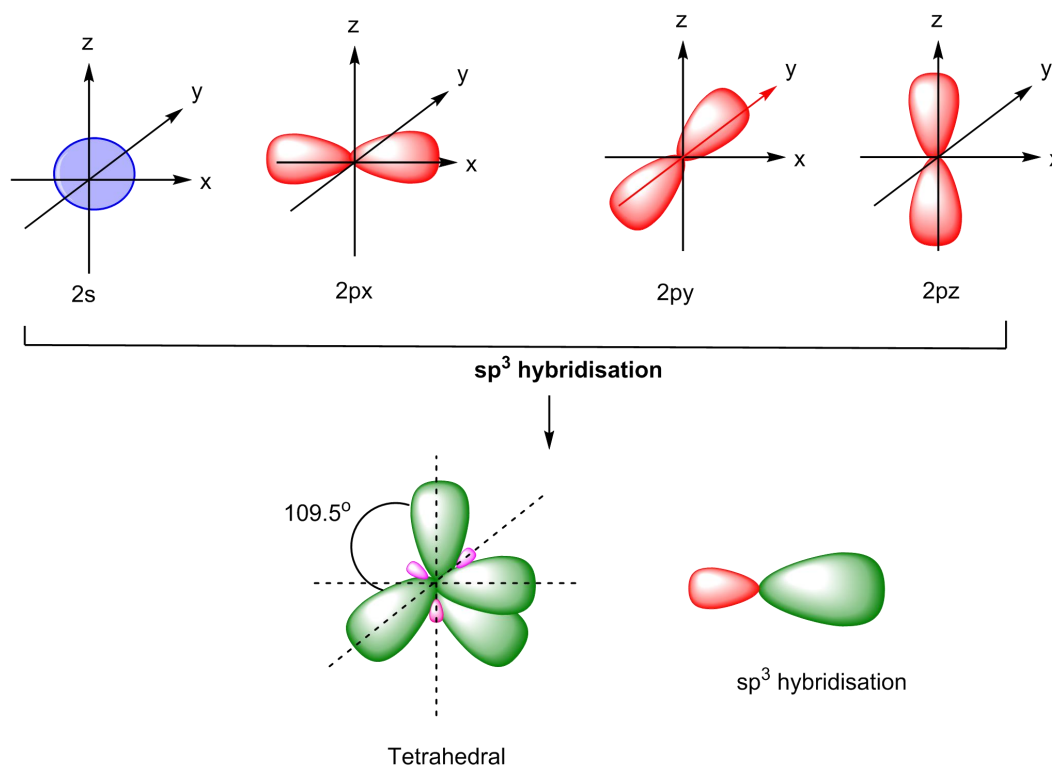

Fig 4.11 formation of four tetrahedral sp^3 hybrid orbitals from the mixing of $1s$ and $3p$ atomic orbitals (sp^3 hybridisation)

Characteristics:

i) These sp^3 hybrid orbitals are equivalent in energy and shape and are oriented along the four corners of a regular tetrahedron. The bond angle between each pair of these orbitals is 109.5° , called tetrahedral angle.

ii) Each sp^3 hybrid orbital has 25% s-character and 75% p-character, hence their shape is closer to that of p-orbitals i.e. are pear shaped.

Examples: AX_4 where $A = C, Si$ and $X = H, F, Cl, Br, I$, simplest of these is CH_4 . In this molecule, C-atom is the central atom which undergoes sp^3 hybridisation as follows:

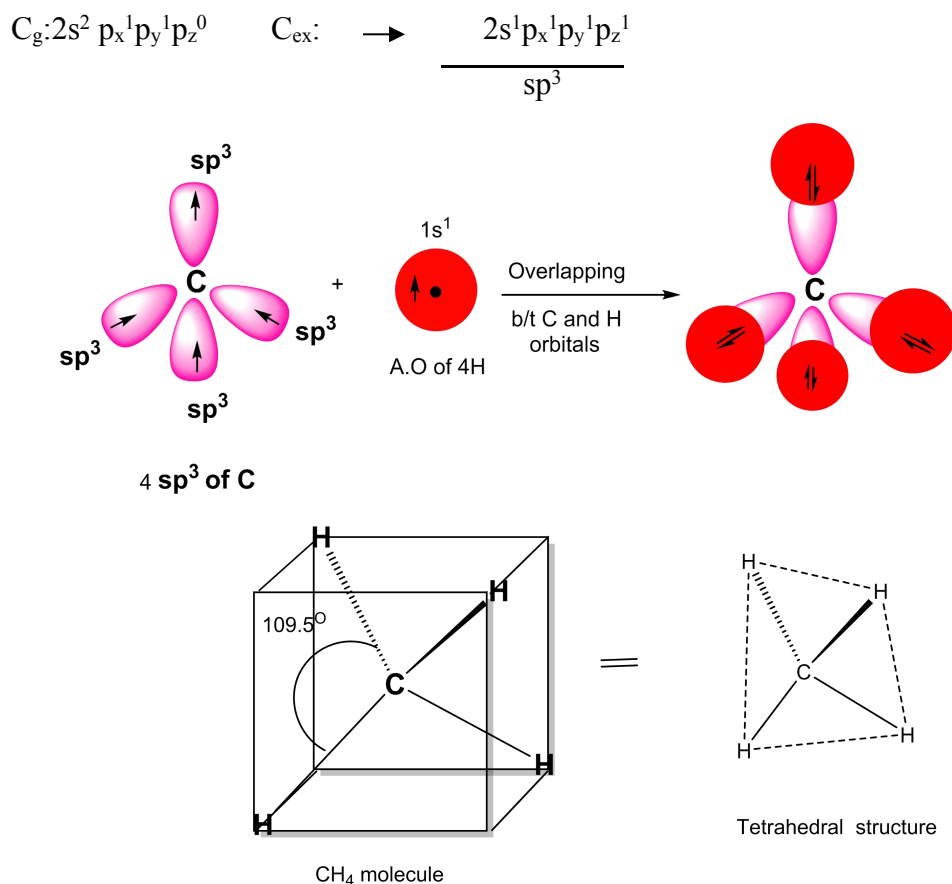

Fig 4.12 formation of four σ covalent bonds by the overlapping of sp^3 hybrid orbitals of C-atom and $1s$ orbitals of four H-atoms

(iv) Sp^3d hybridization:

When one s, three p and one d (generally dz^2) atomic orbitals of the valence shell of the central atom of a given molecule/ion mix up together and give rise to the formation of a set of five hybrid orbitals, the process is known as sp^3d hybridisation and the new orbitals formed are called sp^3d hybrid orbitals. The process of this type of hybridisation has been shown here:

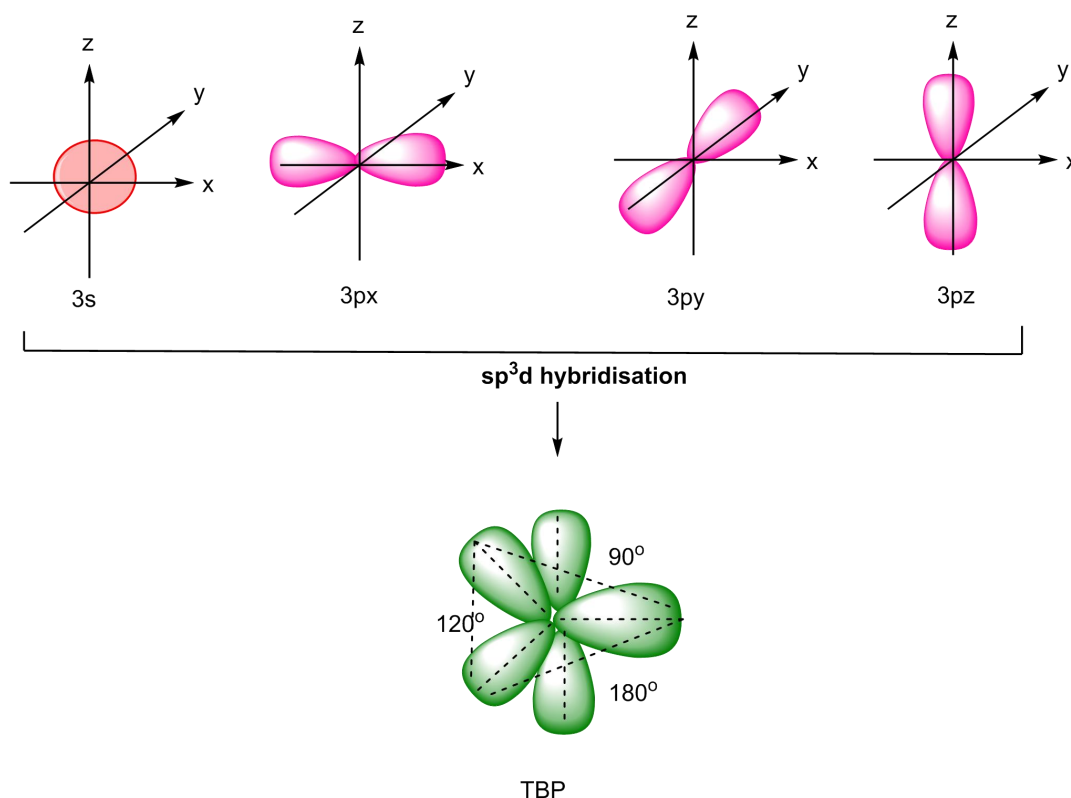
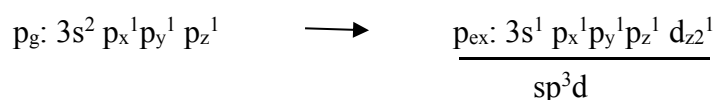

Fig 4.13 formation of five trigonal bipyramidal sp^3d hybrid orbitals from the mixing of one s , three p and one d (d_{z^2}) atomic orbitals (sp^3d hybridisation).

Characteristics:

- i) The sp^3d hybrid orbitals are equivalent in energy and shape and are oriented towards the five corners of a regular trigonal bipyramid i.e. their spatial arrangement is trigonal bipyramidal.
- ii) They do not lie in one plane. Three of the five hybrid orbitals called the basal or equatorial hybrid orbitals are oriented towards the corners of an equilateral triangle forming a triangular plane while the remaining two called axial hybrid orbitals lie above and below the plane on the axis passing through the centre of plane. The angle between each adjacent pair of basal hybrid orbitals is 120° , that between two axial hybrid orbitals is 180° and that between the axial and basal hybrid orbitals is 90° .

Examples: AX_5 molecule ($A = P, As, Sb$ and $X = F, Cl, Br$). Let us discuss the hybridisation and bonding in PCl_5 molecule.



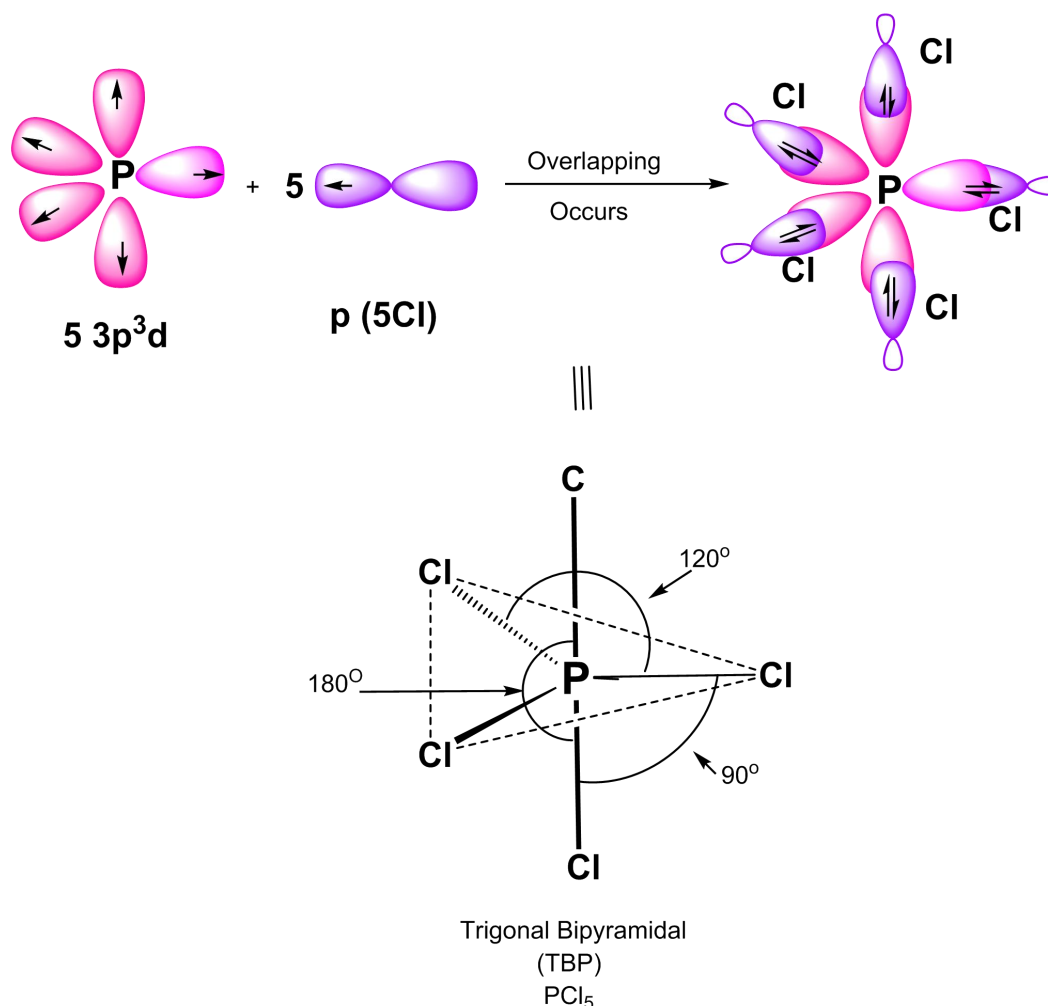
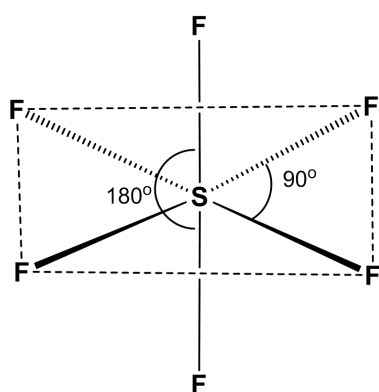
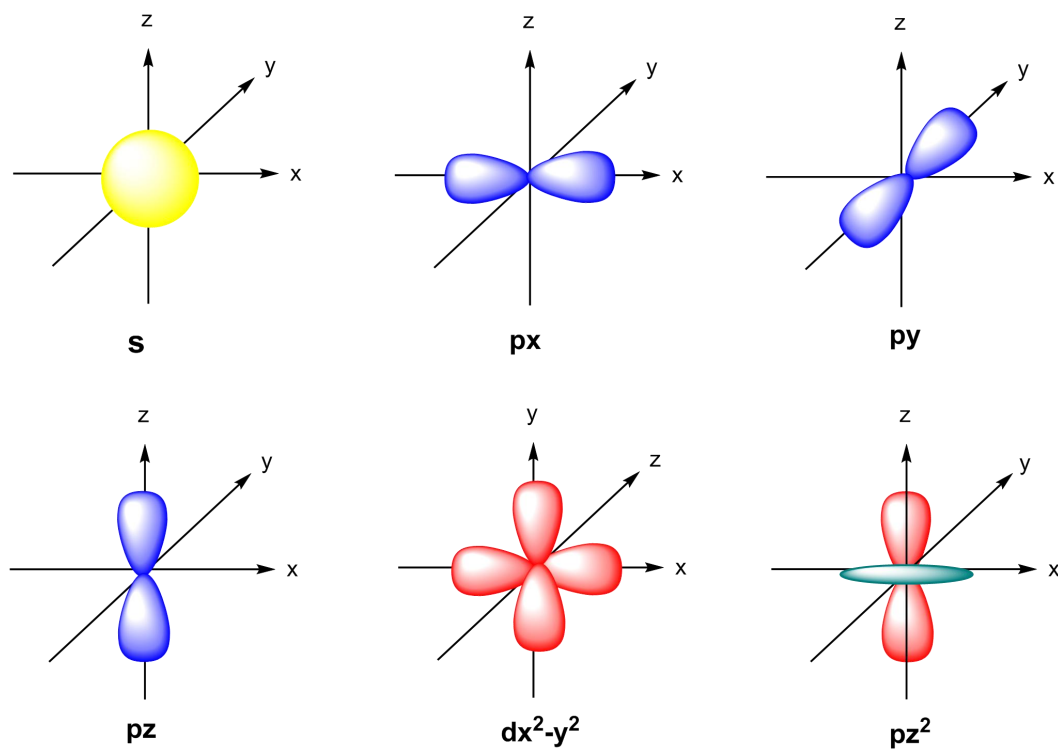

Fig 4.14 Formation of five σ covalent bonds by the overlapping of sp^3d hybrid orbitals of P central atom and p-orbitals of five Cl-atoms

(v) Sp^3d^2 hybridisation:

On mixing one s-orbital, three p-orbitals and two d (generally dx^2-y^2 and dz^2) orbitals of the valence shell of central atom of the given molecule/ion, a set of six hybrid orbitals is formed. This process is known as sp^3d^2 hybridisation and the new orbitals formed are called sp^3d^2 hybrid orbitals. The formation of these orbitals is shown below:



Octahedral complex

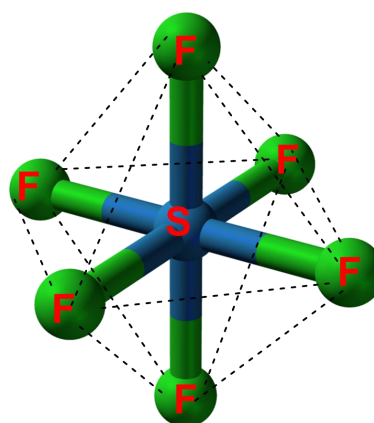

3-D modal of Octahedral complex

Fig 4.15 Formation of six sp^3d^2 hybrid orbitals from the mixing of one s, three p and two d-atomic orbitals (Sp^3d^2 hybridisation).

Characteristics:

- i) All the six hybrid orbitals formed are equivalent in energy and shape and are oriented along the six corners of a regular octahedron i.e. their arrangement in space is octahedral.

ii) All the orbitals do not lie in a plane. Four hybrid orbitals of the six called basal or equatorial hybrid orbitals are lying in square plane while the remaining two called axial hybrid orbitals lie above and below the plane on the axis passing through the centre of the square base. The angles between any adjacent pairs of hybrid orbitals (basal or axial) is 90° .

Examples: AF_6 type molecule ($A=S, Se, Te$). Let us see the process of bond formation in SF_6 molecule.

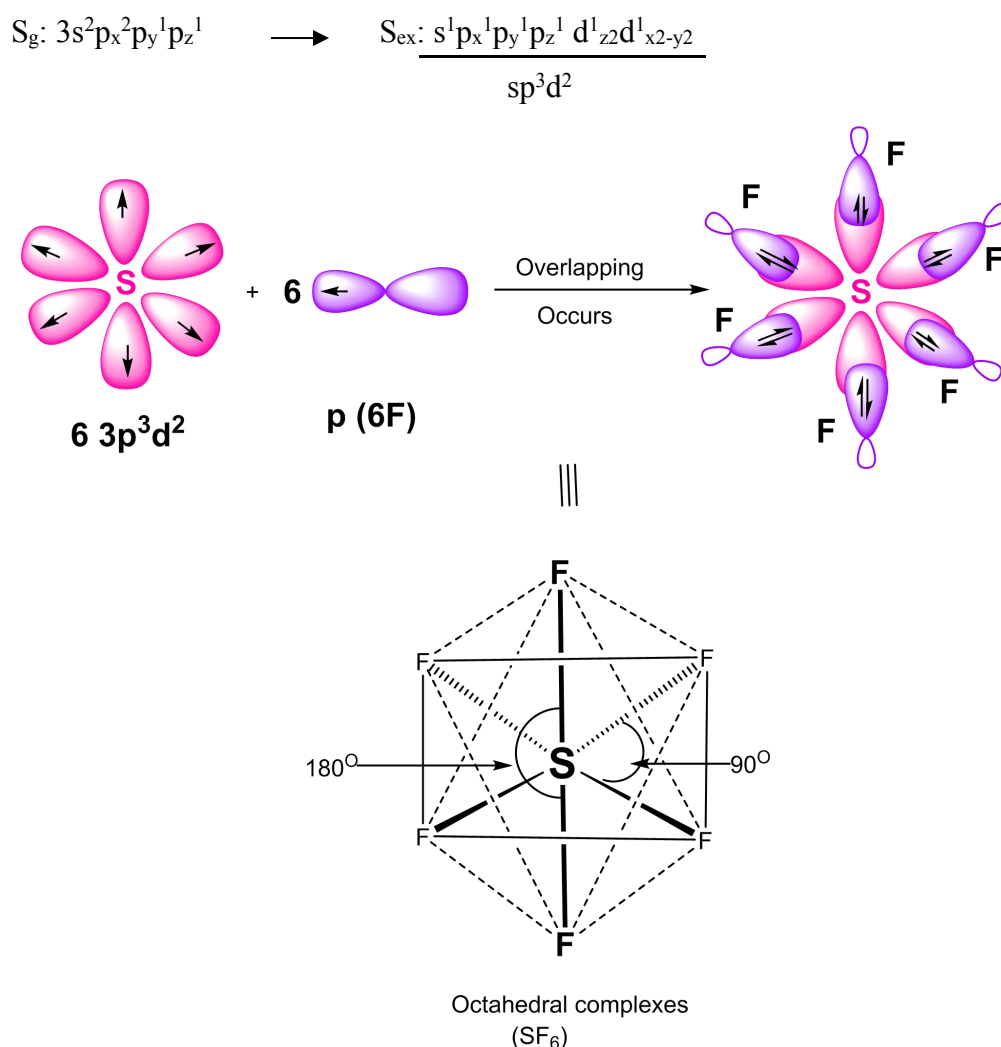

Fig 4.16 Formation of six σ covalent bonds by the overlapping of sp^3d^2 hybrid orbitals of S central atom with p -orbitals of six F atoms

(vi) Sp^3d^3 hybridisation:

When one s , three p and three d (generally d_{xy} , d_{yz} , d_{zx}) orbitals of the valence shell of the central atom in a given molecule/ion mix up together, a set of seven new orbitals is formed. This process of mixing is called sp^3d^3 hybridisation and the new orbitals formed are known as sp^3d^3 hybrid orbitals. Their formation occurs as follows:

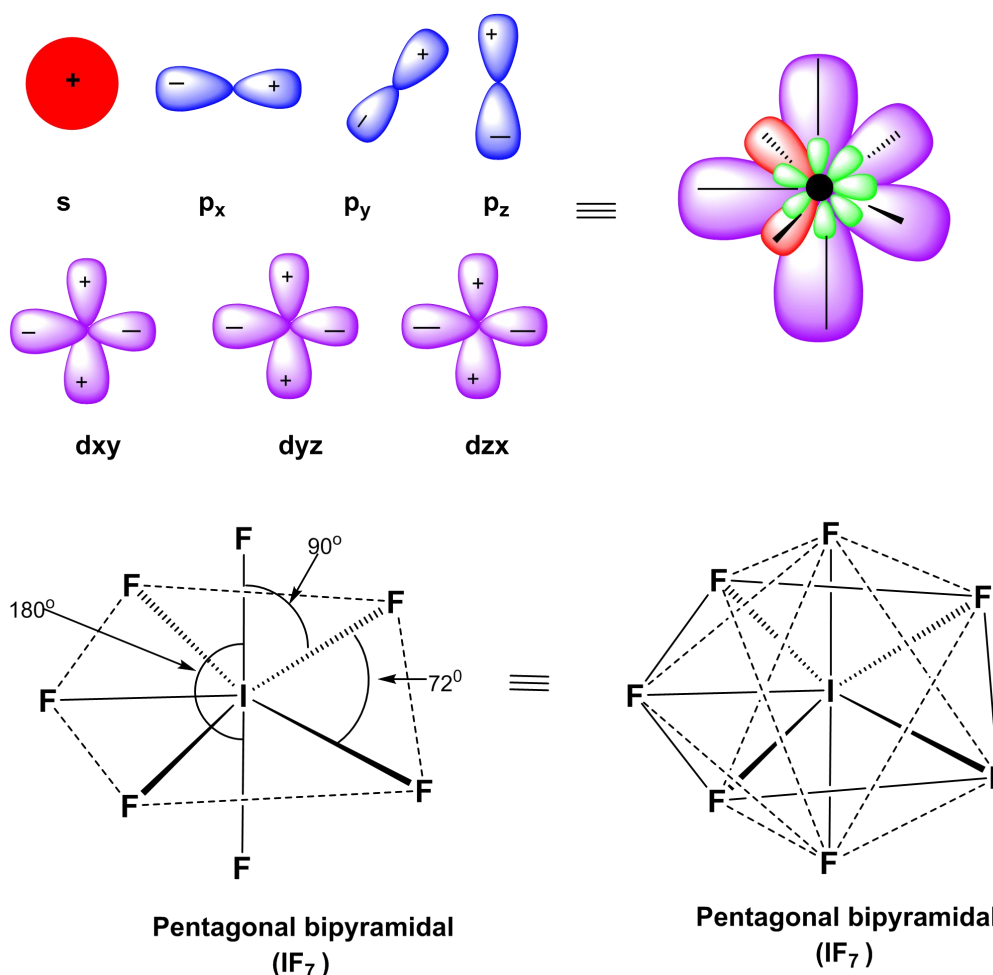
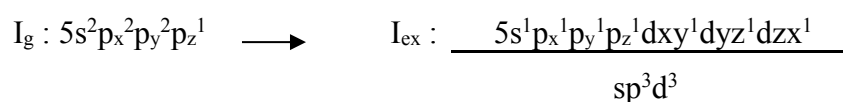

Fig 4.17 Formation of seven sp^3d^3 hybrid orbitals from the mixing of one s , three p and three d -orbitals of the central atom

Characteristics:

- i) All the seven hybrid orbitals are equivalent in energy and shape and are oriented towards the seven corners of a regular pentagonal bipyramid i.e. their spatial arrangement is pentagonal bipyramidal.
- ii) All of them do not lie in one plane. Five of them lie in the pentagonal plane and are called basal or equatorial hybrid orbitals while remaining two called axial hybrid orbitals lie above and below the plane on the axis passing through the centre of the pentagonal plane.
- iii) The angle between any adjacent pair of basal hybrid orbitals is of 72° and that between an axial and a basal hybrid orbital is equal to 90° .

Example: IF₇ (an interhalogen compound)



4.4.2 Shape of simple inorganic molecules and ions:

In all the above examples, the central atom uses all of its valence electrons for the bond formation i.e. the hybrid orbitals of the central atom and atomic orbitals (s or p) of the attached atoms are half filled, and after overlapping of the appropriate orbitals, form the normal σ covalent bonds. The molecules so formed have regular geometrical shape i.e. there is no distortion in the shape of the molecule.

However, there are examples in which the central atom of the molecule/ion undergoes a particular type of hybridisation which involves orbital/s with paired electrons as such along with orbitals having unpaired electrons. These hybrid orbitals (with both paired and unpaired electrons) overlap with the orbitals of approaching atoms to give the normal as well as dative σ bonds or sometimes the hybrid orbitals with paired electrons do not overlap with the orbitals of approaching atoms and remain attached as such with the central atom in the molecules as lone pairs. The presence of these lone pairs causes distortion in the shape of the molecule/ion. This leads to irregular geometry of the molecule/ion.

The geometrical shapes, and process of hybridisation involved, of some inorganic molecule/ions along with those given under VSEPR Theory in the syllabus will be discussed after the discussion of VSEPR Theory.

4.5 VALENCE SHELL ELECTRON PAIR REPULSION (VSEPR) THEORY

The valence bond theory also called the atomic orbital theory can explain the geometrical shape of many molecules/ions of both transition and non-transition elements by employing the concept of hybridisation. But many molecules/ions remain unexplained in terms of their geometry by this method. To overcome this shortcoming, a modification of VBT was developed by Gillespie and Nyholm which can predict the shapes of many species which are left uncovered by the concept of simple hybridisation. According to this theory “The shape or the geometry of a polyatomic molecule/ion of non-transition (mostly non-metallic) element depends upon the number and nature of the electron pairs contained in the valence shell of the central atom.” Thus the electrons already present in the valence shell plus the additional electrons acquired by the central atom as a result of bonding with other atoms are called its valence shell electrons. These electrons may be present as bonding or non-

bonding electron pairs in the central atom which arrange themselves in such a way that there is a minimum repulsion between them and the molecule has minimum energy and maximum stability. Since there can be only one orientation of orbitals corresponding to minimum energy, hence the molecule attains a definite shape/geometry.

The following rules have been proposed by Gillespie and Nyholm to explain the shape of some inorganic molecule/ions-

i). If the central atom of a molecule/ion contains only the bond pairs of electron in the valence shell, the geometrical shape of the molecule/ion is said to be regular (or undistorted) e.g. linear, trigonal planar, tetrahedral, octahedral etc., respectively. This fact is evidenced by the examples given above in the chapter of hybridisation.

ii). When the valence shell of the central atom in a molecule/ion contains the bonding electron pairs and non-bonded electron pairs (called lone pairs), the molecule/ion has distorted or irregular geometrical shape due to the alteration in bond angles which is caused by the presence of lone pairs on the central atom.

This happens because of the following fact. Since the lone pair of electrons is under the influence of only one nucleus (of central atom), i.e. mono centric, these electrons occupy a broader orbital with a greater electron density radially distributed closer to that nucleus than bonding pair of electrons which is under the influence of two nuclei of bonded atoms i.e. bicentric. Its location between the atoms depends on the electronegativities of the combining atoms. Thus lone pairs experience more freedom than the bonded pairs and hence exert more repulsion on any adjacent electron pair than a bond pair does on the same adjacent electron pair. The repulsion among the electron pairs follows the sequence as:

Lone pair-Lone pair > Lone pair - π bond > π bond- π bond > Lone pair- bond pair > π bond - bond pair > bond pair-bond pair repulsion

Because of this fact, if the central atom in a molecule/ion contains both lone pairs (l.ps.) and bonded pairs (b.ps.), there occurs a contraction in the bond angle (which is formed between two adjacent b.ps.). More the number of l.ps. on the central atom, greater is the contraction caused in the bond angle. This statement is supported by the bond angles observed in CH₄, NH₃ and H₂O:

molecules	CH ₄	NH ₃	H ₂ O
Type of hybridisation involved	sp ³	sp ³	sp ³
No. of l.ps. on the central atom	0	1	2

Bond angle		109.5°	107.3°	104.5°
Contraction in the bond angle	-	≈2°	≈5°	

iii) \angle BAB in AB₂ type molecules decreases with increasing electronegativity of the atom B where A is a central atom. This is because as the electronegativity of the attached atom B increases, the b.p. of electrons moves away from the central atom and experiences less repulsion from its l.p.s. and enhanced distance between two bond pairs also causes less repulsion between them resulting in the contraction in bond angle.

For example, (i) PI₃(≈102°)>PBr₃(≈101.5°)>PCl₃(≈100°)

(ii) AsI₃(≈101°)>As Br₃(≈100.5°)> AsCl₃(≈98.5°)

iv) The repulsion between the electron pairs in filled shells is larger than that between electron pairs in incompletely filled shells. As an example, let us compare \angle HOH and \angle HSH in H₂O and H₂S molecules. It has been observed that \angle HOH (104.5°)>> \angle HSH (92.2°). In both the molecules, the central atoms O and S contain eight electrons in their valence shells, six of their own and two from H-atoms. Thus the valence shell of O-atom (with 2s and 2p orbitals only) is completely filled but that of S-atom is incompletely filled due to the availability of 3d-orbitals (which remain vacant) in addition to 3s and 3p-orbitals. The total capacity of the valence shell of S-atom is to accommodate a maximum of 18 electrons (from 2n² rule).

v) The bond angle involving the multiple bonds are generally larger than those involving only single bonds. However, the geometrical shape of the molecule is not affected by multiple bonds.

Limitations:

The VSEPR Theory suffers from certain limitations which are as follows:

(i) This theory cannot explain the shapes of very polar molecules and those having inert pair of electrons.

(i) The shapes of the molecules which have extensive delocalised π electron systems are not explained by this theory.

(ii) This theory does not cover certain transition metal complexes.

The VSEPR Theory in combination with the concept of hybridisation has been successfully used to discuss and explain the geometrical shapes of most of the covalent inorganic molecules/ions. Here we shall discuss the type of hybridisation and mode of bonding in certain inorganic molecule/ions in addition to those given in the syllabus of VSEPR theory.

A. Shape of SnCl₂ molecule (sp² hybridisation)

The central atom, Sn, has the ground state valence shell configuration as given below:

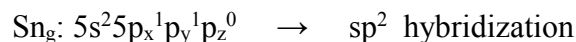

This atom undergoes partial hybridisation mixing up together the paired 5s and unpaired 5p_x and 5p_y-orbitals, leaving behind the empty p_z-orbital, to form three sp² hybrid orbitals one of which is occupied by the electron pair coming from the 5s-orbital. The process of hybridisation and overlapping of hybrid orbitals with atomic orbitals of Cl-atoms have been shown below:

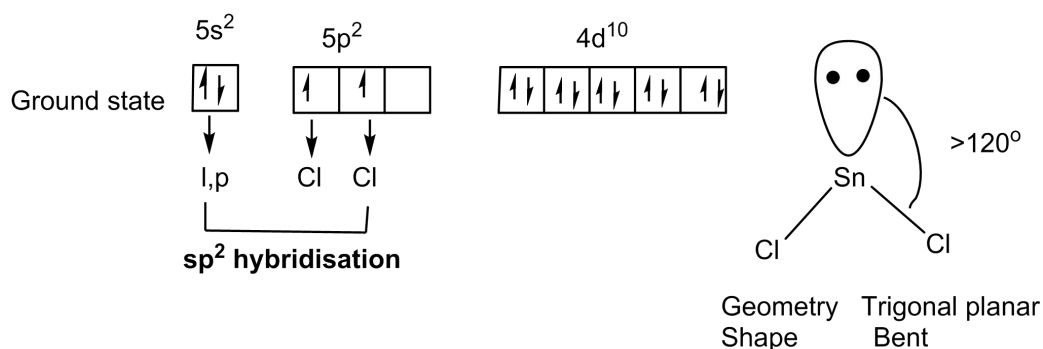
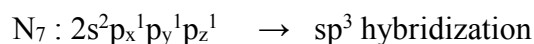

Fig 4.18 Formation of hybrid orbitals and their overlapping with 3p-orbitals of Cl atoms to give SnCl₂ molecule

Two unpaired hybrid orbitals of Sn atom overlap with unpaired p-orbitals of approaching Cl-atoms and give SnCl₂ molecule which contains one lone pair of electrons on Sn-atom. Because of the greater repulsion of lone pair on bond pairs, the ∠Cl SnCl is less than 120°, the expected angle in case of sp² hybridisation. The molecule thus attains angular or bent shape.

B. Shape of NH₃ Molecule (sp³ hybridisation)

In NH₃ molecule, the central atom N has following ground state valence shell configuration:



All these atomic orbitals participate in hybridisation and give four equivalent sp³ hybrid orbitals. One of them contains an electron pair (lone pair) and three half filled hybrid orbitals then overlap with 1s orbitals of three H-atoms to form σ covalent bonds (N-H bond).

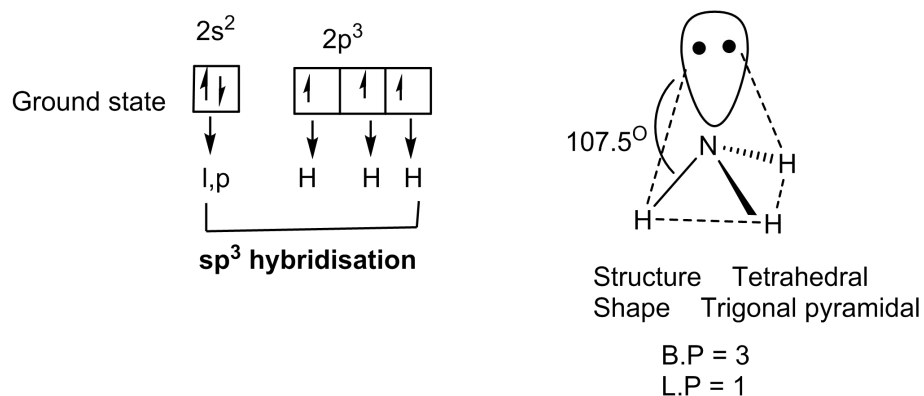
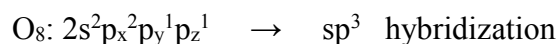

Fig 4.19 Formation of hybrid orbitals and their overlapping with 1s orbitals of 3H atoms to give NH₃ molecule

From the figure, it is evident that one lone pair of electrons is present in NH₃ molecule which exerts more repulsion on bonded pairs than that operating between the bonding pairs of electrons. The net result is that the NH₃ molecule attains trigonal pyramidal shape with the bond angle of 107.3°, a deviation of about 2° from the tetrahedral angle of 109.5°.

C. Shape of H₂O Molecule (sp³ hybridisation)

The ground state valence shell configuration of the central atom O of H₂O molecule is:



All these atomic orbitals undergo hybridisation and give rise to four equivalent sp³ hybrid orbitals. Two of these hybrid orbitals are half filled and remaining two contain lone pairs of electrons. The unpaired hybrid orbitals then overlap with 1s orbitals of two H-atoms to form σ covalent bonds (O-H bonds).

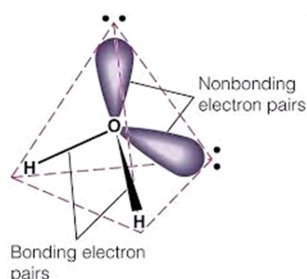
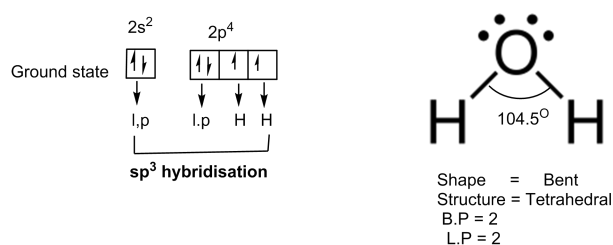

Fig 4.20 Formation of hybrid orbitals and their overlapping with 1s orbitals of two H-atoms to give H₂O molecule.

There are two lone pairs of electrons present in H₂O molecule which exert strong repulsion on each other and move away towards the bonded pairs of electrons. This brings the bonded pairs closer to each other thereby causing contraction in the bond angle. H₂O molecule thus attains a V-shaped geometry with the bond angle of 104.5°, a deviation of a bond 5° from the tetrahedral angle of 109.5°

D. Shape of H₃O⁺ Ion (sp³ hybridisation)

Hydronium ion (H₃O⁺) is formed by the combination of H₂O molecule and H⁺ ion in which H₂O molecule donates one of its lone pairs of electrons to H⁺ ion and it accepts that lone pair of electrons in its vacant 1s orbital.

Actually, filled sp³ hybrid orbital of O-atom in H₂O molecule overlaps with empty s-orbital of H⁺ ion as follows thereby forming a coordinate covalent bond:

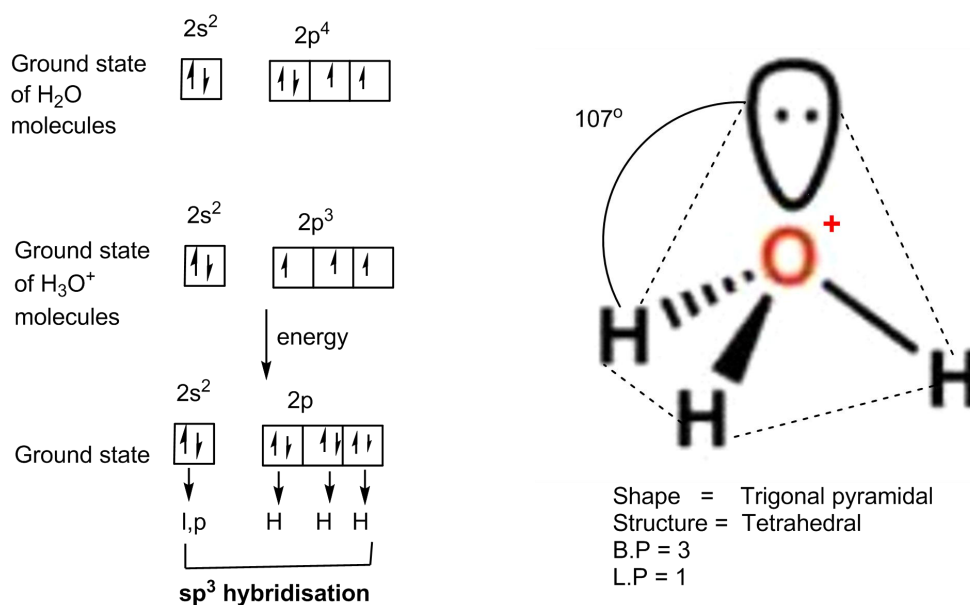
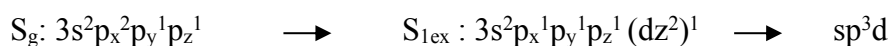

Fig 4.21 Overlapping of filled sp³ hybrid orbital of O-atom in H₂O and empty 1s orbital of H⁺ ion to form H₃O⁺ ion

This ion has trigonal pyramidal shape like that of NH₃ molecule with one lone pair of electrons on O-atom.

E. Shape of SF₄ molecule (sp³d hybridisation)

In this molecule the central S-atom is in its first excitation state in which one of its p_x electrons is promoted to the next empty dz^2 orbital. The electronic configuration in the ground and first excited state has been shown below:



All these atomic orbitals of S_{ex} central atom get hybridised to give five sp^3d hybrid orbitals directed toward the corners of a trigonal bipyramid, one of these hybrid orbitals contains an electron pair (b.p.) and the next four orbitals have unpaired electrons which overlap with the p-orbitals of four F-atom to form SF_4 molecule.

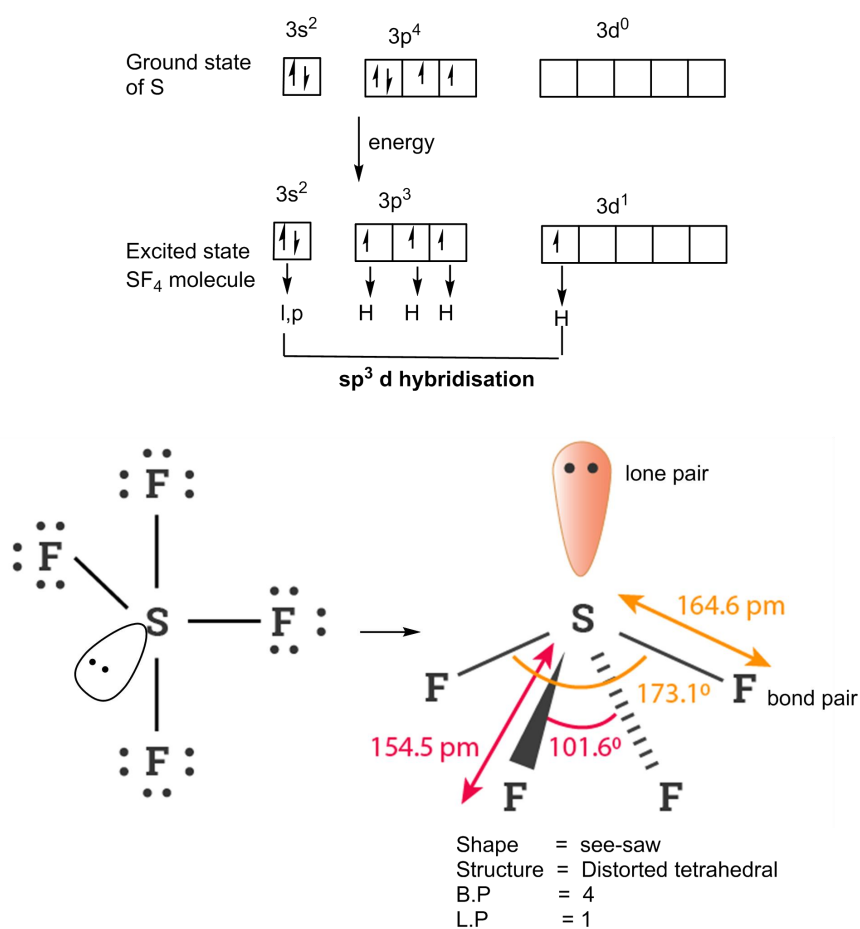
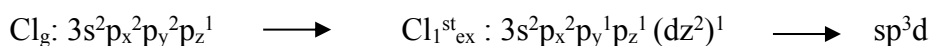

Fig 4.22 Formation of five hybrid orbitals of S_{ex} atom and their overlapping with p-orbitals of four F-atom to give SF_4 molecule

This molecule attains a see-saw shape because of the presence of one lone pair of electron (sometimes also called distorted tetrahedral) and lone pair lies at one of the basal positions (the molecule has 1 lone pair and 4 bonded pairs)

F. Shape of ClF_3 molecule (sp^3d hybridisation)

Cl is the central atom in this molecule with valence shell electronic configuration in ground and first excited state as given below wherein one electron from a filled p-orbital say p_y is promoted to a vacant d-orbital (*viz.* dz^2) of the same shell:



All the orbitals of the valence shell of $\text{Cl}_1^{\text{st}_{\text{ex}}}$ atom are mixed up together to produce five sp^3d hybrid orbitals. Two of the hybrid orbitals have lone pairs of electrons and three have unpaired electrons which then overlap with unpaired p-orbitals of three F-atoms to form σ covalent bonds. The lone pairs are said to occupy the equilateral positions and the molecule attains T-shaped structure with the bond angle of 87.6° instead of 90° due to the distortion caused by lone pairs. The T-shaped structure has been confirmed by the experimental evidences. The whole act of hybridisation, overlapping and bond formation can be shown as below (molecule has 2 lone pairs and 3 bonded pairs):

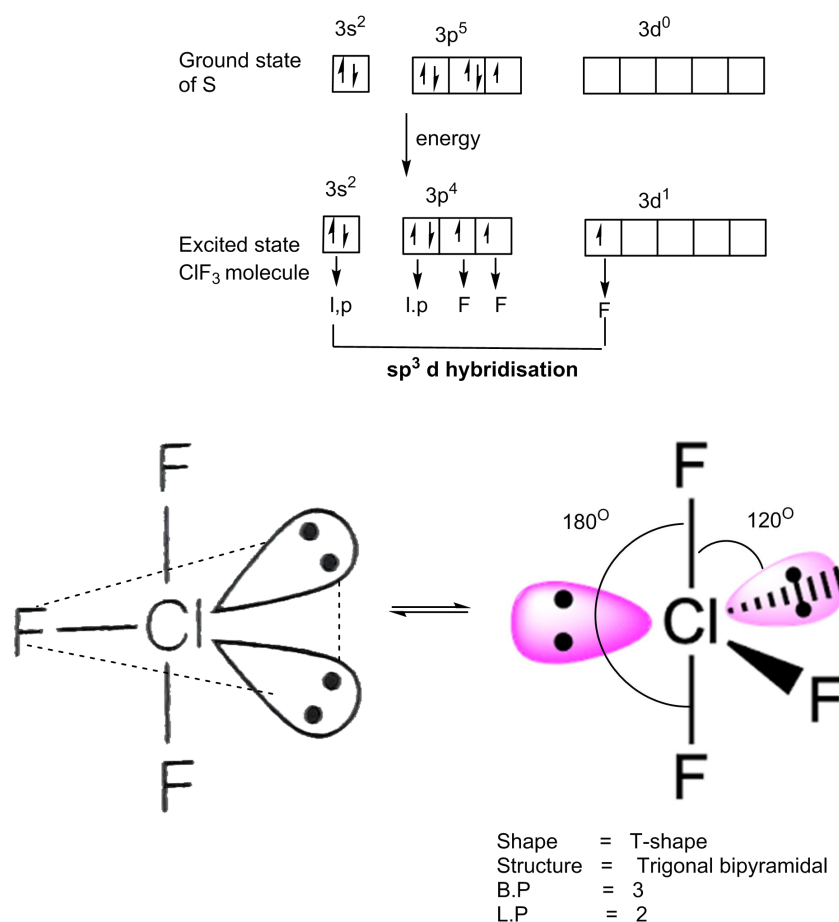
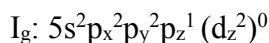

Fig 4.23 Formation of five hybrid orbitals of $\text{Cl}_1^{\text{st}_{\text{ex}}}$ atom and their overlapping with p-orbitals of three F-atoms to give ClF_3 molecule

The mode of hybridisation shape and bonding in BrF_3 and ICl_3 molecules can also be explained on the similar grounds as in the case of ClF_3 .

G. Shape of ICl_2^- Ion (sp^3d hybridisation)

In ICl_2^- ion, the central atom I (iodine) has the ground state electronic configuration in its valence shell as shown below:



All these atomic orbitals including a vacant d_{z^2} orbital participate in hybridisation to produce five sp^3d hybrid orbitals of which three orbitals contain lone pairs, one hybrid orbital is half filled which overlaps with half filled p-orbitals of Cl-atom to give normal σ bond and one hybrid orbital remains vacant and overlaps with the filled orbital of Cl^- ion to give a coordinate covalent σ bond (dative bond). The lone pairs occupy the equatorial positions and the bonded pairs are situated in axial positions. The ion has 3 lone pairs and 2 bonded pairs as shown below and has almost linear shape:

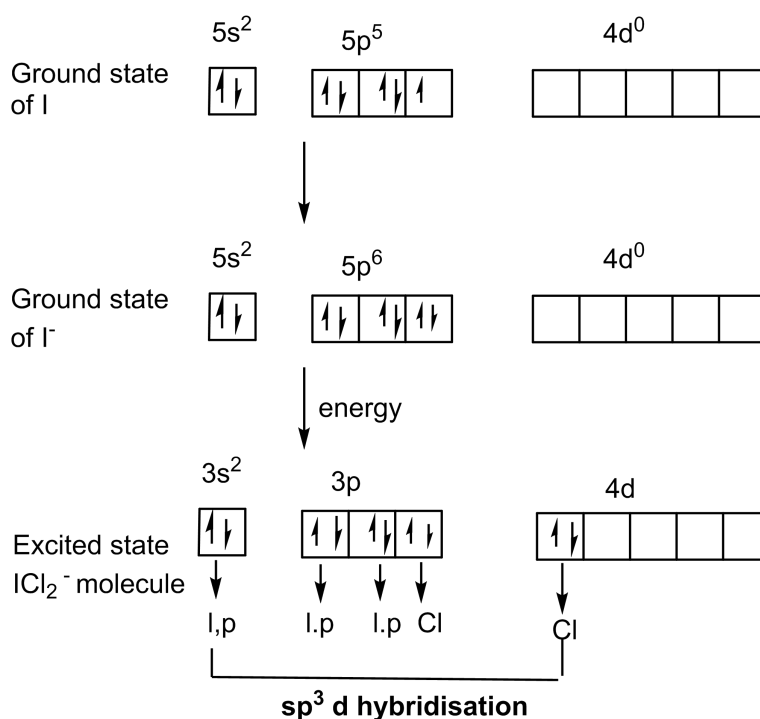

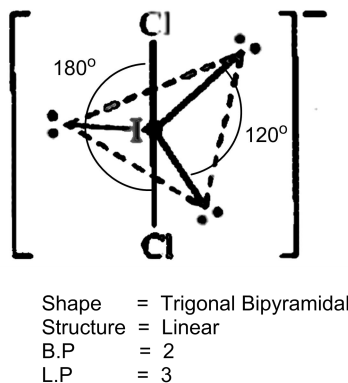
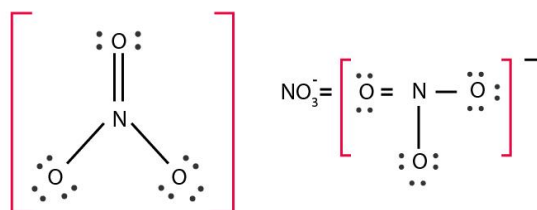

Fig 4.24 Formation of five sp^3d hybrid orbitals of central atom, I and overlapping of one of these hybrid orbitals with p -orbital of Cl atom and that of filled p -orbital of Cl ion with vacant hybrid orbital of I atom

H. Shape of NO_3^- ion (sp^2 hybridisation)

The central N-atom in this ion is sp^2 hybridised leaving a pure p_z orbital behind. These sp^2 hybridised orbitals then overlap with the orbitals of one O atom and one O^- ion to form two normal σ bonds and one dative σ bond as follows:



Bond angle = 120°
Hybridization = sp^2
Geometry = Trigonal planar

Fig 4.25 Formation of two normal σ bonds, one dative σ bond and one π bond between N central atom and oxygen atoms/ion

I. Shape of SO_4^{2-} ion (sp^3 hybridisation)

S atom has 6 electron its valence shell and in this ion all the valence electrons of S are present in unpaired state i.e. S_{2ex} state. Out of six, four orbitals are hybridised as follows:

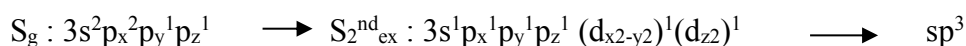

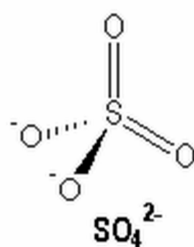
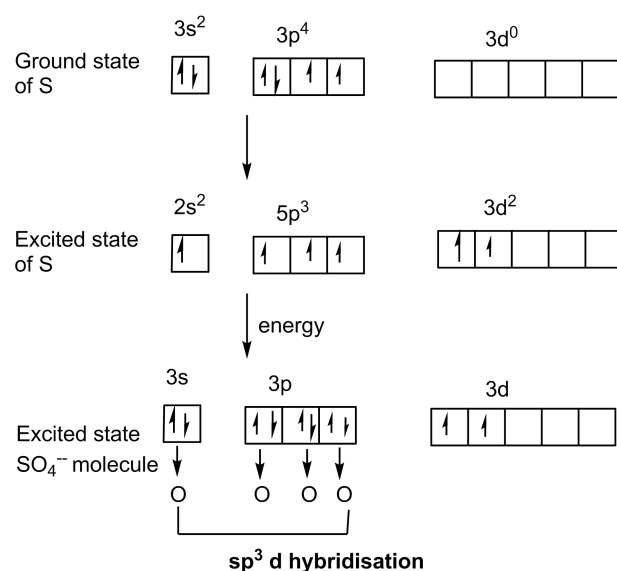

Bond angle = 109.5°
Shape = Tetrahedral

Fig. 4.26 structure of the so_4^{2-}

The SO_4^{2-} ion can be shown as follows:

For details please refer to sp^3 hybridization & CH_4 molecule.

It has tetrahedral shape like CH_4 molecule but has two single and two double bonds (σ and π). On the similar grounds the type of hybridisation and shape of XeF_2 , XeF_4 , $XeOF_4$ and XeF_6 molecules can be discussed. It is to be kept in mind that F-atom is monovalent, O-atom is bivalent (forms one σ and one π -bond with central atom) and central atom requires only that number of hybrid orbitals which can form σ bonds with approaching atoms and these hybrid orbitals are generally unpaired or half filled. Hence in the above molecules partial hybridisation may take place.

XeF_2 : sp^3d 3 lone pairs + 2 bonded pairs and linear in shape

XeF_4 : sp^3d^2 2 lone pairs + 4 bonded pairs and square planar

$XeOF_4$: sp^3d^2 1 lone pair + 5 bonded pairs +1 π bond and is square pyramidal

XeF_6 : sp^3d^3 1 lone pair + 6 bonded pairs and pentagonal pyramidal

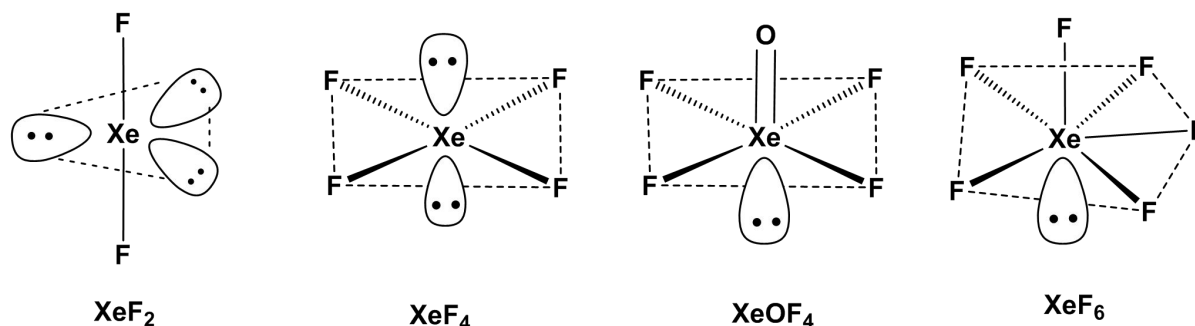

Fig 4.27 Shapes of XeF_2 , XeF_4 , XeOF_4 and XeF_6 molecules

4.6 MOLECULAR ORBITAL THEORY (MOT)

To explain the formation of the covalent bond in molecules/ions and their behaviour like relative bond strength, magnetic property etc., a new approach was developed by Hund and Mulliken in 1932 and later by Lennard Jones and Coulson. This approach is known as **Molecular Orbital Theory**. This theory treats the covalent bonds in terms of Molecular Orbitals (MOs) which are associated with the entire molecule and result from the linear combination of atomic orbitals (LCAOs) of constituent atoms of the molecule/ion. Thus the molecules are supposed to have their own orbitals of varying energy in the same way as the isolated atoms have. The difference between an atomic orbital and a MO is that an electron in an atomic orbital is influenced by one nucleus only i.e. an atomic orbital is monocentric while an electron in a M.O. is under the influence of all the nuclei contained in the molecule/ion, i.e. a M.O. is polycentric.

The atomic orbitals combining linearly to form the MOs must be of the similar energy and same symmetry and may be of the two similar atoms of a homonuclear diatomic molecule/ion (e.g. H_2 , H_2^+ , N_2 , O_2 , O_2^{2-} etc.) or may be of two different atoms of a heterodiatom molecule/ion (e.g. CO , NO , CN^- , NO^+ etc.).

The main characteristics of MOT are as follows:

- (i) The atomic orbitals (AOs) combining linearly together to form the molecular orbitals (MOs) lose their identity and the number of atomic orbitals is equal to the number of molecular orbitals formed.
- (ii) MOs are the energy states of the molecules/ions in which the electrons are filled just like in AOs of the atoms.

(iii) The linear combination of the AOs may occur in two different ways, i.e. the additive combination gives bonding molecular orbitals (BMOs) and the subtractive combination gives antibonding molecular orbitals (ABMOs).

(iv) The bonding MO has lower energy and hence greater stability than the antibonding MO obtained from two AOs.

(v) The bonding MOs are denoted by σ , π , δ , Ψ etc. symbols while the antibonding MOs by σ^* , π^* , δ^* , Ψ^* etc. symbols.

(vi) The shapes of MOs formed depend on the type of combining AOs and mode of combination and their filling takes place according to the rules which are applicable for AOs, viz. Aufbau principle, Pauli's exclusion principle and Hund's rule of maximum multiplicity.

Formation of MOs LCAO approximation

Suppose Ψ_A and Ψ_B represent the wave function of the electrons in the A.Os. of the atoms A and B respectively. Then linear combination of these A.Os. may be done in two ways:

$$\text{i) } \Psi^b = \Psi_A + \Psi_B \text{ (} ++ \text{ combination) } \dots\dots\dots (4.10)$$

This additive combination of AOs gives bonding molecular orbital for which the wave function is denoted by Ψ^b . This is also called constructive interaction. Further, from the above equation, we have

$$(\Psi^b)^2 = (\Psi_A + \Psi_B)^2 = \Psi_A^2 + \Psi_B^2 + 2\Psi_A\Psi_B \dots\dots\dots (4.11)$$

Or $(\Psi^b)^2 > \Psi_A^2 + \Psi_B^2$ by a factor $2\Psi_A\Psi_B$ where squares of respective Ψ s give the probability of locating the electrons in the different orbitals. From this we infer that electrons prefer to reside in the BMO rather than the AOs and placing electrons in BMO yields a stable covalent bond. In this MO the electron density is greater between the nuclei of bonding atoms.

$$\text{ii) } \Psi^* \text{ (or } \Psi^a) = \Psi_A - \Psi_B \text{ (} +- \text{ (plus minus combination) } \dots\dots (4.12)$$

This subtractive combination of AOs gives the antibonding molecular orbital, the wave function for which is represented by Ψ^* (psi star). This is also called destructive interaction. From this equation, we have

$$(\Psi^*)^2 = (\Psi_A - \Psi_B)^2 = \Psi_A^2 + \Psi_B^2 - 2\Psi_A\Psi_B \dots\dots (4.13)$$

Or $(\Psi^*)^2 < \Psi_A^2 + \Psi_B^2$ by a factor $2\Psi_A\Psi_B$. From this relation it can be concluded that electrons prefer to occupy the AOs rather than the ABMO and placing electrons in this MO opposes the bond formation. The electron density in this MO, decreases to zero between the nuclei.

The pictorial representation of the formation of BMOs and ABMOs from AOs is shown below:

s-orbitals: combination of s-orbitals gives only σ MOs (both bonding and antibonding)

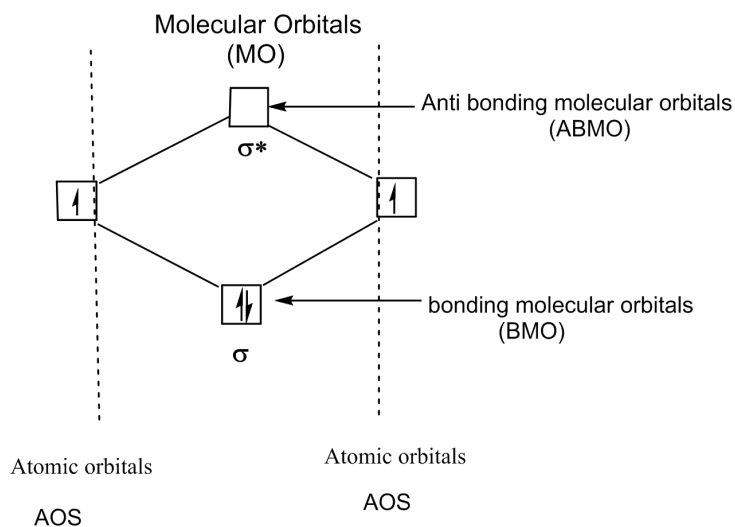
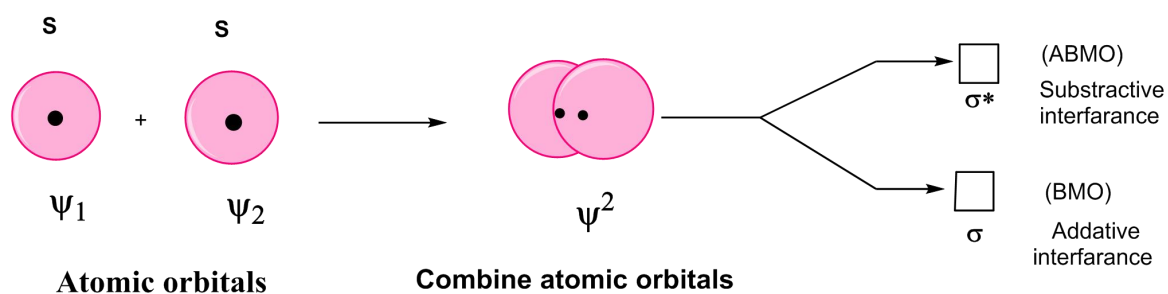
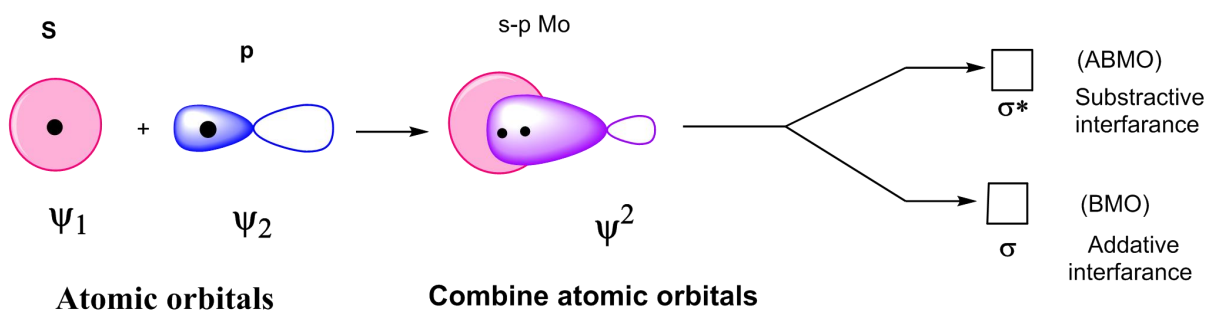
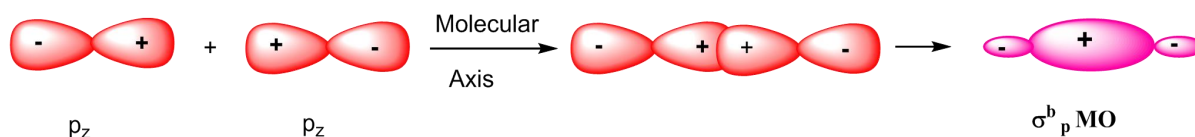

Fig. 4.28 picture of the molecular orbital diagram.

s and p-orbitals: This combination also gives only σ M.Os. This is possible only along molecular axis i.e. orientation of p-orbital is along molecular axis.



p-orbitals: The linear combination of p-orbitals may give σ as well as π MOs (b and * both).



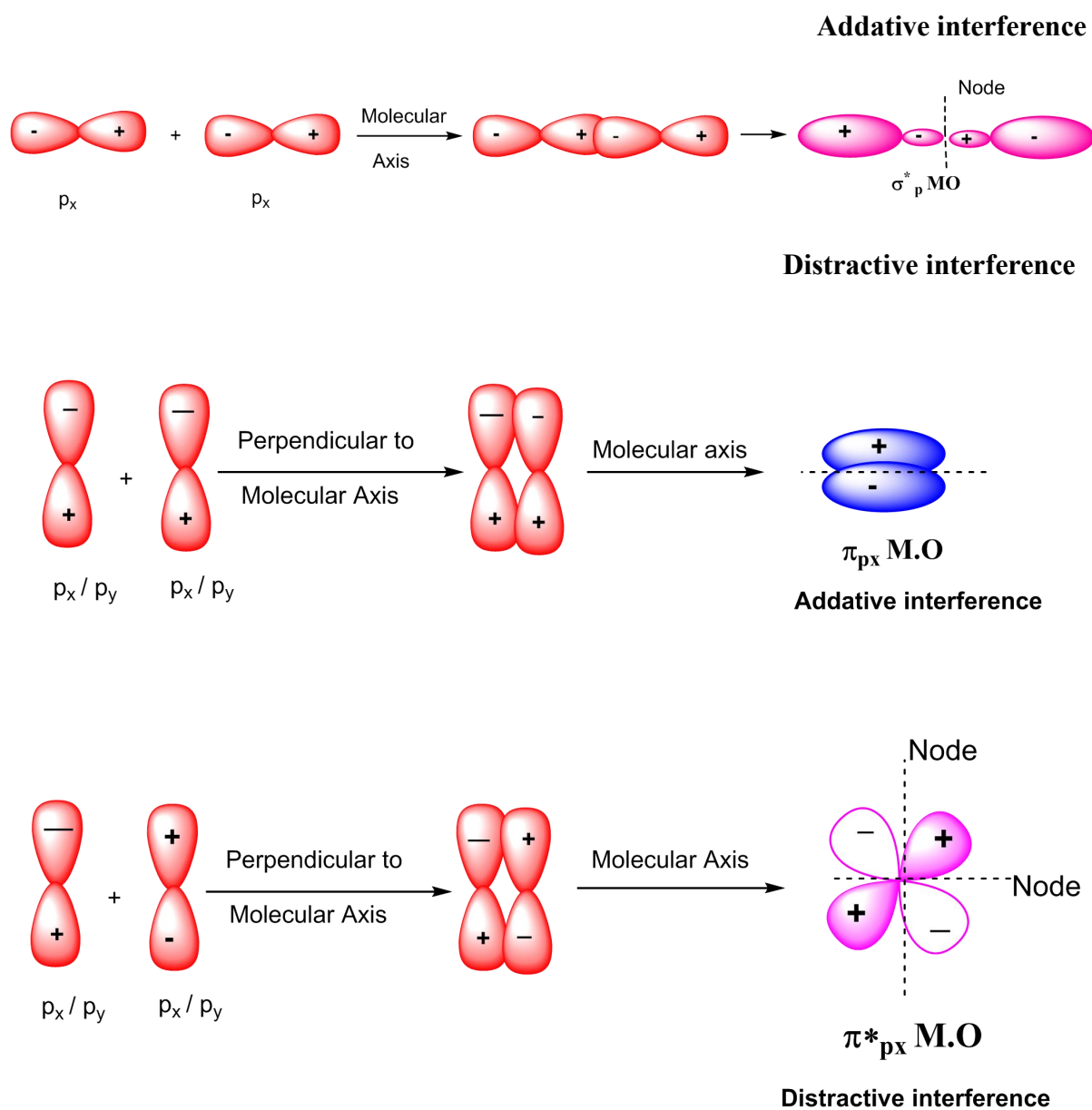

Fig. 4.29 picture of the various combination of atomic orbital.

It is to be noted that the interaction of AOs occurs to form the MOs only if the symmetry consideration are taken care of, e.g. $s-p_x$ combination is allowed but $s-p_y$ and $s-p_z$ combination is disallowed if p_x lies along the molecular axis. Similarly, p_x-p_y , p_x-p_z and p_y-p_z combinations are disallowed. p_y-p_y and p_z-p_z combination will produce π M.Os. if X- axis is the molecular axis. The $\pi_{p_y}^b$ and $\pi_{p_z}^b$ as well as $\pi_{p_y}^*$ and $\pi_{p_z}^*$ MOs have the same energy, i.e. these are degenerate orbitals.

Energy level diagrams of the molecules/ions

The MOs of the molecules/ions if arranged in the increasing order of their energy, we get the so called energy level diagrams for them in which the MOs are taken as energy levels.

The electron are filled in these energy levels (MOs) from the lowest energy MO to higher energy MOs according to Aufbau principle. The degenerate MOs are filled according to Hund's rule, i.e. first singly and then in pairs. This condition is applicable to both homonuclear and heteronuclear diatomic molecules/ions.

At the same time if these MOs are written in a sequence using their symbols along with the number of electrons contained in them, then we get the molecular electronic configuration in the same way as the electronic configuration of atoms. This sequence according to increasing energy is:

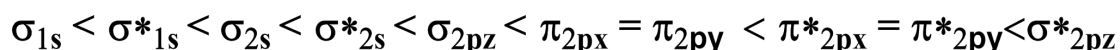

This sequence has been found to hold for O₂, F₂ etc. but for hypothetical B₂, C₂, N₂ etc. σ_{2pz} is of slightly higher energy than $\pi_{2p_{y/z}}$ MOs due to certain well established reasons and hence the sequence becomes (taking x axis as the molecular axis).

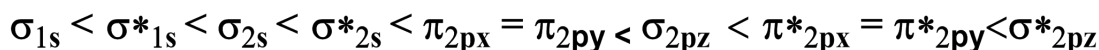

Bond order: The bond order is the number of bonds in the molecular species and is given as:

Bond Order = $(N_a - N_b)/2$, N_a = number of antibonding electrons, N_b =number of bonding electrons

4.6.1. Homonuclear diatomic molecules/ions:

❖ Molecular orbital diagram of the H₂

i) H₂ molecule (i.e. 1+1=2 valence shell electrons) It is simplest case with 1s¹ configuration in each H-atom. Molecular electronic configuration:

$(\sigma^b_{1s})^2 < (\sigma^*_{1s})^0$. Also denoted as KK in the higher molecules.

$$\text{Bond Order} = (2-0)/2=1$$

∴ There is single bond between H-atoms in H₂ molecule (H-H).

The order is calculate as follow,

$$\text{Bond Order (BO)} = \frac{\text{Number of Bonding Electron} - \text{Number of Antibonding Electron}}{2}$$

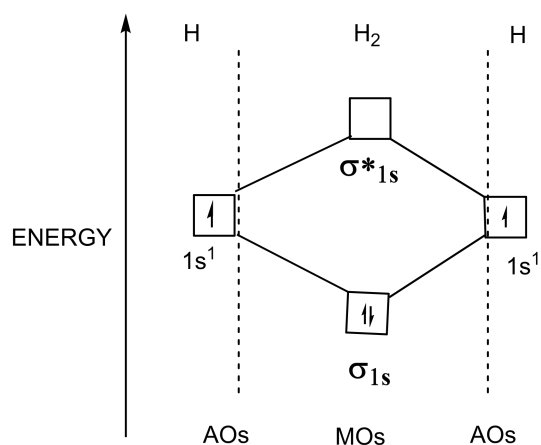

Fig 4.30 Energy level diagram of H₂

$$\text{B.O of H}_2 \text{ Molecule} = 2 - 0/2 = 1$$

❖ **Molecular orbital diagram of the N₂ molecule :**

N₂ molecule (5+5=10 valence shell electrons)

Each N-atom has 2s²2p³ electronic configuration in the valence shell. Thus Molecular electronic configuration of N₂ is:

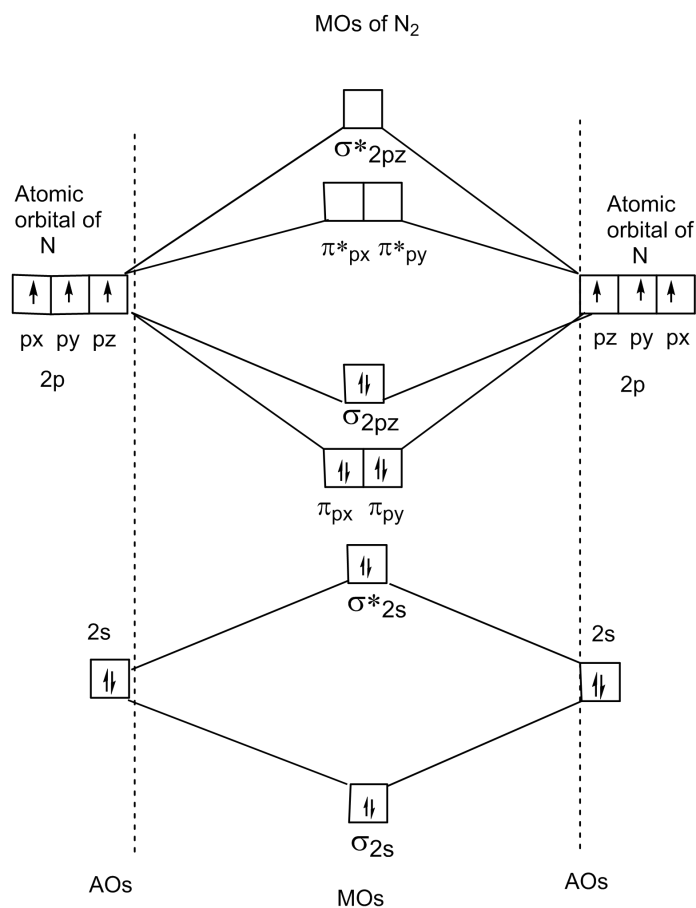
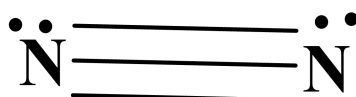

Fig. 4.31 MOT of the N₂ molecule

$$\text{Bond Order (BO)} = \frac{\text{Number of Bonding Electron} - \text{Number of Antibonding Electron}}{2}$$

$$\text{B.O Of N}_2 = \frac{8-2}{2} = 3$$

It means triple bond in between nitrogen-nitrogen atom in N₂ molecule. And the structure of the N₂ molecule according to the MOT is :



$$\text{Electronic configuration of N}_2 = (\text{KK})^4 < \sigma_{2s}^2 < \sigma_{2s}^{*2} < \pi_{2px}^2 = \pi_{2py}^2 < \sigma_{2pz}^{*2}$$

❖ **Molecular orbital diagram of the O₂ molecule :**

O₂ molecule (6 + 6 = 12 valence shell electrons)

Each O-atom has 2s²2p⁴ valence shell electronic configuration. 1s² electrons of both O atoms belonging to KK MOs. are non-bonding.

∴ Electronic configuration of O₂ molecule is:

$$\text{Electronic configuration of O}_2 = (\text{KK})^4 < \sigma_{2s}^2 < \sigma_{2s}^{*2} < \sigma_{2pz}^2 < \pi_{2px}^2 = \pi_{2py}^2 < \pi_{2px}^{*1} = \pi_{2py}^{*1}$$

Because of the presence of two unpaired electrons

in ABMOs, O₂ molecule is paramagnetic in nature.

$$\text{Bond Order (BO)} = \frac{\text{Number of Bonding Electron} - \text{Number of Antibonding Electron}}{2}$$

Bond order = (8-4)/2 = 2, There is a double bond between O-atoms in O₂ molecule (O=O)

And structure of the O₂ molecule is :

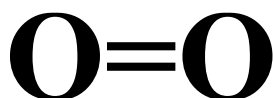

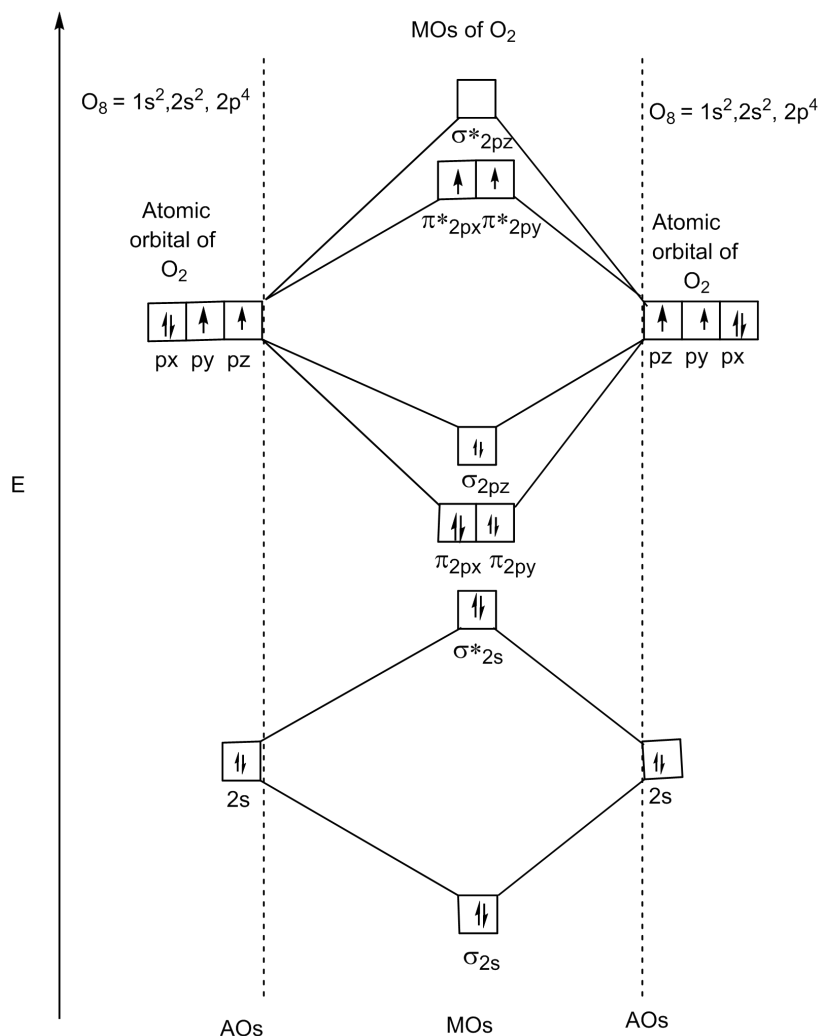

Fig 4.32 Molecular orbital diagram of O_2

Similarly we can write down the electronic configuration and draw the energy level diagrams for O_2^+ , O_2^- (super oxide ion), O_2^{2-} (peroxide ion) and F_2 molecule. O_2^+ (oxygenyl ion) has one electron less than O_2 molecule. O_2^- ion will have one electron more than O_2 molecule. Both are paramagnetic. O_2^{2-} ion and F_2 molecule will have two electrons more than O_2 which go to $\pi_{2p_y}^*$ and $\pi_{2p_z}^*$ MOs thereby making them diamagnetic.

4.6.2. Heteronuclear diatomic molecules/ions:

❖ Molecular orbital diagram of the CO molecule

CO molecule ($4+6=10$ valence shell electron).

This molecule is isoelectronic with N₂ molecule and has similar molecular electronic configuration and energy level diagram to that of N₂ molecule. There is only a minor difference in electronic distribution in A.Os. as given below:



Electronic configuration of CO molecule is (the M.O. energy level sequence is like that of N₂):

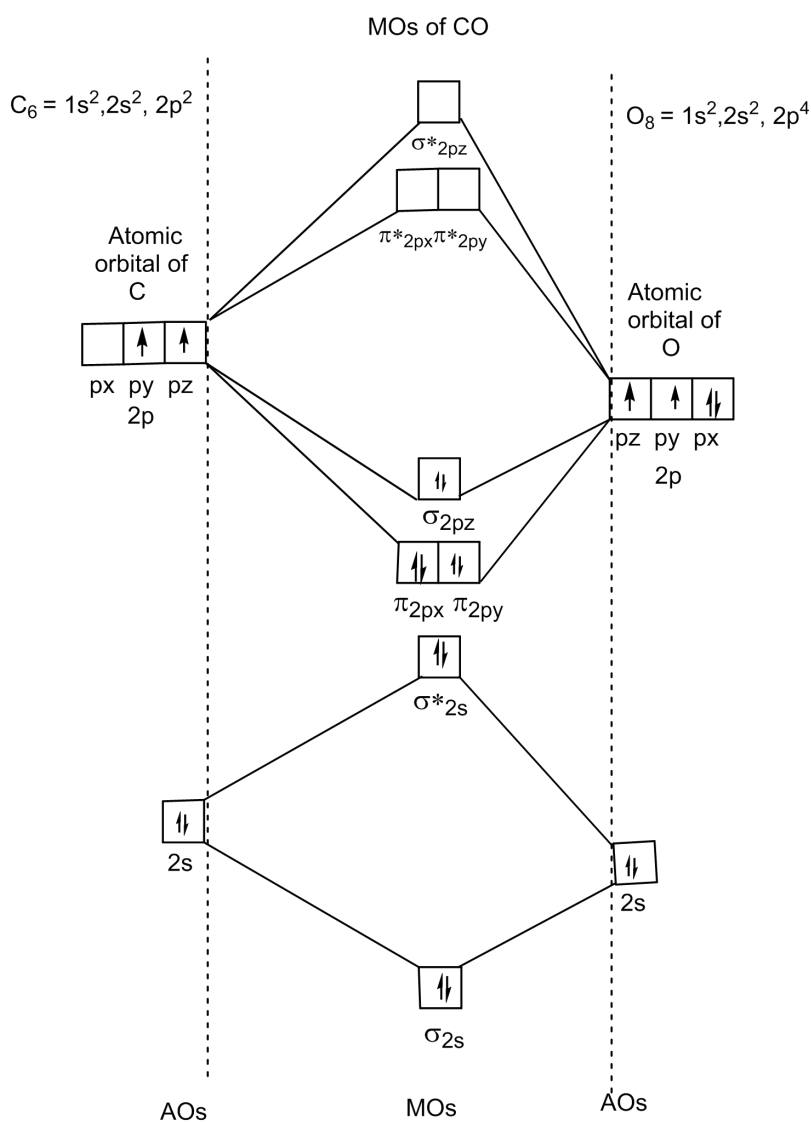
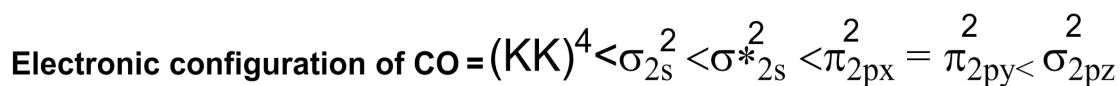

Fig 4.33 Energy level diagram of CO

Bond order = $8 - 2 / 2 = 3$ (triple bond)

❖ **Molecular orbital diagram of the NO molecule**

ii) NO molecule (5+6=11 valence shell electron), N: $2s^2 2p^3$ and O: $2s^2 2p^4$

The electronic configuration of NO molecule is (the M.O. energy level sequence is like that of O_2) but electron distribution is slightly different.

It is paramagnetic due to the presence of one unpaired electron. The bond between N and O is $2\frac{1}{2}$ times as strong as a normal covalent bond.

Similarly, we can write down the electronic configuration and draw energy level diagram for NO^+ (one electron less than NO) ion which is diamagnetic and has only paired electrons upto $\pi^*_z p_x$ M.Os. and $\pi^*_z p_y$ M.O. is vacant.

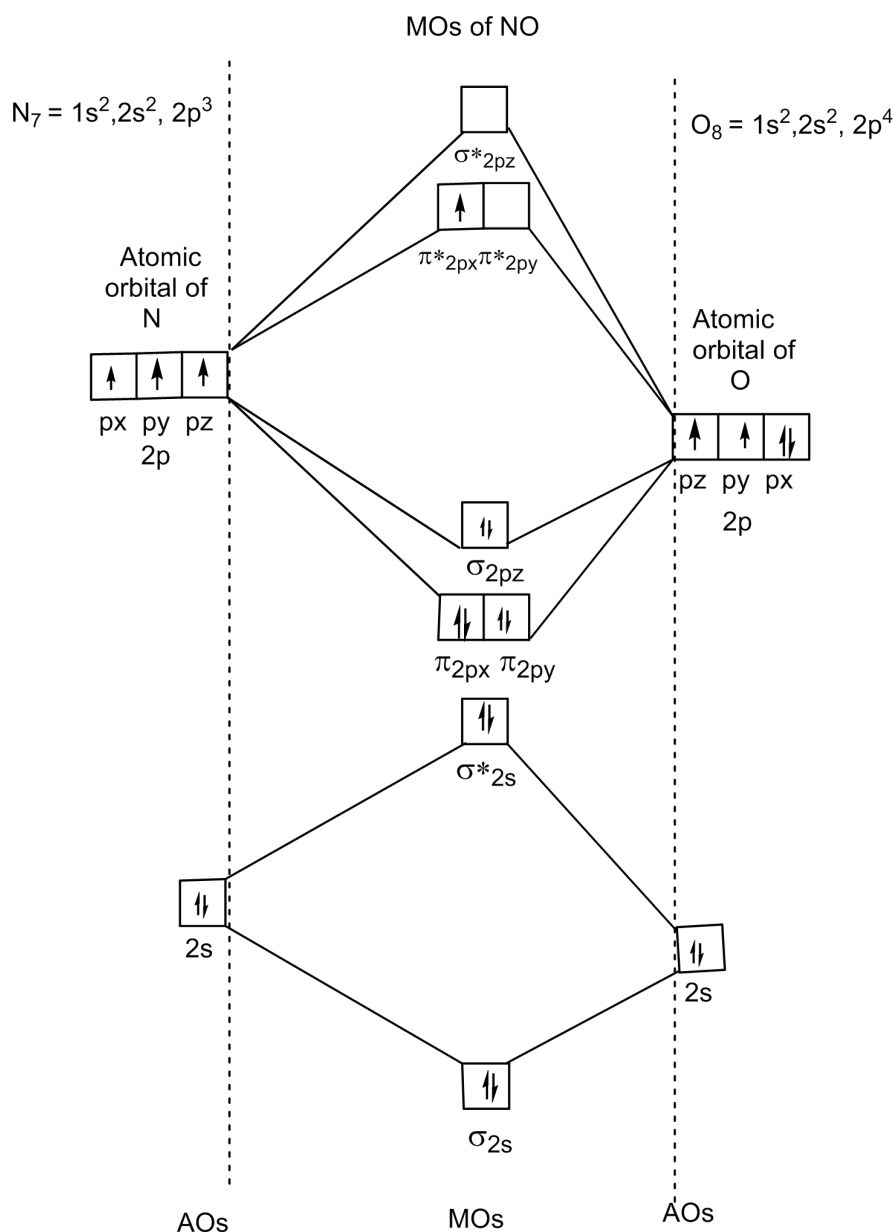

Fig. 4.34 Molecular orbital diagram of NO

Electronic configuration of CO = $(\text{KK})^4 < \sigma_{2s}^2 < \sigma_{2s}^{*2} < \pi_{2px}^2 = \pi_{2py}^2 < \sigma_{2pz}^2 < \pi_{2px}^{*1} = \pi_{2py}^{*0}$

4.7. MULTICENTRE BONDING IN ELECTRON DEFICIENT MOLECULES

In the covalent compounds, in general, an electron pair bond holds two atoms together but there are a number of compounds in which an electron pair holds several atoms together. In these cases, it is said that multicentre or delocalized bond exists. The best known molecule which displays multicentre bonding is B_2H_6 , diborane.

A number of evidences show that the B_2H_6 molecule has hydrogen bridged structure in which four H-atoms are terminal hydrogen atoms (H_t) and the remaining two H-atoms are the bridging hydrogen atoms (H_b). The four H_t atoms are bonded with B-atoms by the normal electron pair bonds (two H-atoms are attached to each B-atom) and H_b -atoms form a multicentre (3c-2e) bond with each B-atom.

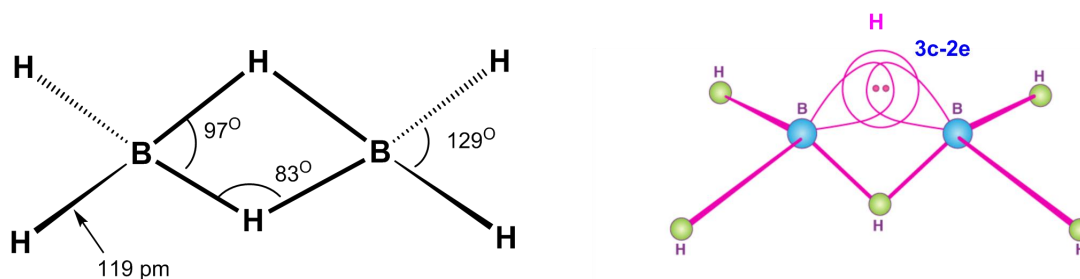
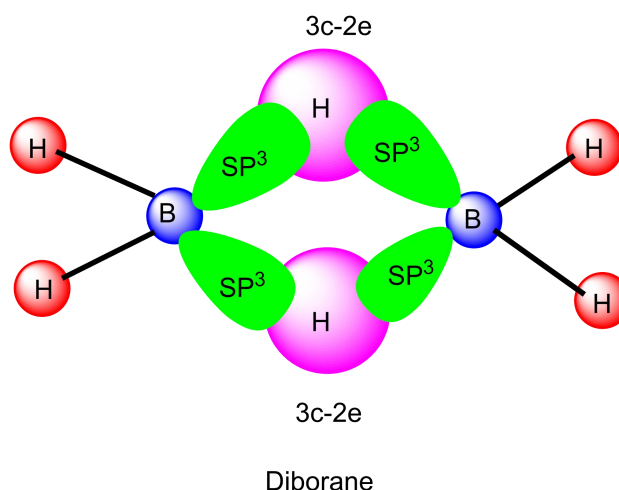

4.35 Structure of the diborane

Boron has valence shell configuration: $\text{B}_g: 2s^2p^1 \rightarrow \text{B}_{ex}: s^1p_x^1p_y^1p_z^0 \rightarrow sp^3$ hybridization

Thus a maximum of three unpaired orbitals are available in B-atom to form three electron pair bonds with H-atoms to give BH_3 . But the given molecule is B_2H_6 , it means $\text{H}_3\text{B}-\text{BH}_3$ type situation must be there and there are no electrons available to form the B-B bond in this molecule. This anomaly has been explained as follows:

Each B-atom undergoes sp^3 hybridisation. Two of the hybrid orbitals (half filled) form two σ bonds with two H_t atoms in each B-atom. Now one half filled (shaded) orbital of say B_1 and empty hybrid orbital of B_2 overlap jointly with half filled $1s$ orbital of H_b atom to give $\text{B}_1\text{H}_b\text{B}_2$ type multicentre bond. Similarly, another 3c-2e bond is formed by the overlapping of empty hybrid orbital of B_1 , half filled hybrid orbital (shaded) of B_2 and half filled $1s$ -orbital of another H_b -atom. These 3c-2e bonds are banana shaped. Therefore, this structure of B_2H_6 is also known as banana structure. Thus the H_b atoms in this molecule may be said to show bivalence which is possible only when the two H_b atoms are bonded with both the B-atoms forming two BHB bridging or 3c-2e bonds.

Another example of multicentre bonding is H_2^+ (hydrogen molecule ion) which contains a 2c-1e bond.

4.8. BOND STRENGTH

By bond strength we mean how strong is the bond between the atoms in a molecule. Bond length, bond multiplicity and extent of overlapping of atomic orbitals in addition to bond energy are the factors which determine the bond strength.

It has been observed that as the bond multiplicity increases, the bond length decreases thereby increasing the bond strength. Similarly, as the extent of overlapping between the atomic orbitals increases, the bond formed becomes stronger. That is why a σ bond is stronger than a π bond. Another important factor influencing the bond strength is the bond energy (bond strength \propto bond energy).

4.8.1 Bond energy:

The bond energy can be explained in two ways:

(i) Bond formation energy (ii) bond dissociation energy

(i) **Bond Formation Energy:**

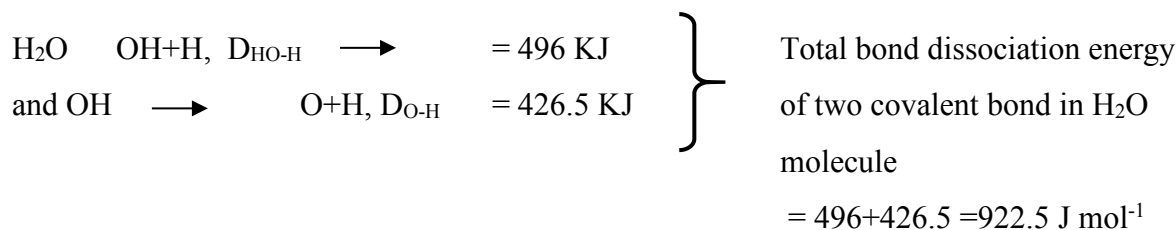

The average bond energy for O-H bond in water is $461.2 \text{ kJ mol}^{-1}$. Thus, it can be generalized as:

Average bond dissociation energy of A-B bond in AB_n gaseous molecule

$$= \frac{\text{sum of successive A-B bond dissociation energies}}{\text{Total number of A-B bonds in } \text{AB}_n \text{ molecule (n)}}$$

Total number of A-B bonds in AB_n molecule (n)

4.8.2 Measurement of bond energy:

i) In diatomic molecules

The determination of bond energy in a diatomic molecule containing a covalent bond involves the measurement of heat of formation of the molecule from its free atoms. But normally this cannot be measured directly because a compound is formed from molecules and not from free atom as well as a compound on dissociation splits up into molecules and not into free atoms of its component elements. Further, a molecule cannot be completely dissociated into its free atoms merely by heating. This can, however, be obtained from heat of reaction which, in turn, is measured from the change in the degree of dissociation with temperature and from heat of sublimation.

ii) In polyatomic molecule

The average bond energy in a polyatomic molecule can be obtained from measured heats of formation and heats of atomisation. For example, to obtain the average bond energy for the C-H bond in methane, it requires measurement of the heats of combustion of methane,

graphite and hydrogen gas together with the heats of atomization of graphite and hydrogen gas.

4.9 PERCENTAGE OF IONIC CHARACTER

The percentage of ionic character of a polar covalent bond (also called polarity) depends on two factors: (i) dipole moment and (ii) electronegativity difference between the combining atoms. Accordingly, various methods are employed to calculate the percentage of ionic character of a covalent bond.

i) Dipole moment (dpm) method

A polar molecule acts as a dipole i.e. $A^{\delta+} - B^{\delta-}$ ($\chi_A < \chi_B$) because of the electronegativity difference between the combining atoms. The degree of polarity in the molecule is given by the dipole moment (μ) which is the product of the magnitude of the charge at each centre (this is equal and of opposite in nature at the two centres) and the distance separating the two centres, i.e. positive and negative.

Thus, $\mu = qd$, where q is magnitude of charge at each centre and d is distance between the two poles. The measured (or experimental) dipole moment (μ_{exp}) of a molecule can be used to evaluate the ionic character in a bond.

$$\begin{aligned} \text{\% ionic character} &= \frac{\text{Experimental or measured dipole moment}}{\text{calculated dipole moment (assuming 100\% ionic character)}} \times 100 \\ &= \frac{\mu_{\text{exp}}}{\mu_{\text{cal}}} \times 100 \\ &= \frac{\mu_{\text{exp}}}{\mu_{\text{cal}}} \times 100 \end{aligned}$$

$d_{A-B} \times$ electronic charge

where d_{A-B} is internuclear distance between A and B atoms in AB molecule. For example, the experimental or observed dipole moment of HF is 1.98 D and the internuclear distance (d_{H-F}) is 0.91 Å. If the bond is taken 100% ionic in the molecule, then calculated dipole moment (μ_{cal}) is electronic charge \times internuclear distance = 4.8×10^{-10} esu \times 0.91×10^{-8} cm = 4.37×10^{-18} esu cm = 4.37 D (Å = 10^{-8} cm and D stands for Debye), \therefore % ionic character = $1.98/4.37 \times 100 = 45.3\%$

ii) Electronegativity difference method

In the polar molecule AB, polar covalent bond is present, the polarity or % ionic character which depends on the electronegativity difference between the linked atoms and can be evaluated by using various empirical equations.

(a) Pauling's equation

According to Pauling, the amount of ionic character in the A-B bond is:

$$\% \text{ ionic character} = 1 - e^{1/4(\chi_B - \chi_A)} \quad (\chi_B > \chi_A)$$

With the help of this equation Pauling established the following relation:

$\chi_B - \chi_A$	1.0	1.7	2.0	3.0
% ionic character	~ 22 ~	51 ~	63 ~	91

This shows that when $\chi_B - \chi_A = 1.7$, A-B bond has 50% ionic character and 50% covalent character. When $\chi_B - \chi_A > 1.7$, the bond has more ionic character than the covalent character and when $\chi_B - \chi_A < 1.7$, the bond has more covalent character than ionic character.

(b) Hannay and Smith equation

These two workers proposed a more simplified equation for calculation the % ionic character in a polar covalent bond.

$$\% \text{ ionic character} = [16 (\chi_B - \chi_A) + 3.5(\chi_B - \chi_A)^2] (\chi_B > \chi_A)$$

Using the electronegativity values as calculated by using Pauling's scale and this equation, the percent ionic character of hydrogen halide (gaseous) molecules are as follows:

HF 43%, HCl 17%, HBr 13% and HI 12%

These values reveal that the hydrogen halide molecules in gaseous state, are only partially ionic and mainly covalent.

4.10 SUMMARY

The summary of the present unit is :

- This unit of the study material consists of a concise discussion of covalent bond based on the octet rule and deviation from the octet rule.
- A brief account of polar and non-polar nature of covalent bond has been given. The valence bond theory and its limitations, directional nature of covalent bond as well as pictorial representation along with the formation of sigma and pi bonds have also been discussed.
- The concept of hybridisation has been fruitfully discussed with examples as well as shapes of inorganic molecules and ions based on hybridisation and valence shell electron pair repulsion theory have been given in the simple way.
- Molecular orbital theory, the energy level diagrams of the molecules/ions, multicentre bond, bond strength, bond energy and percentage of ionic character in polar covalent bonds have also been discussed and explained.

4.11 TERMINAL QUESTIONS

- i) The d-orbital involved in sp^3d hybridisation is
(a) d_z^2 (b) dx^2-y^2 (c) d_{xy} (d) d_{zx}
- ii) Which of the following compounds contains covalent bond?
(a) NaOH (b) HCl (c) K_2S (d) LiH
- iii) Which of the following compounds has the least tendency to form hydrogen bond?
(a) HF (b) NH_3 (c) HCl (d) H_2O
- iv) Nitrogen atom in NH_3 molecule is sp^3 hybridised. NH_3 contains a lone pair of electron on N-atom. What is the shape of this molecule?
(a) Tetrahedral (b) square planar
(c) Trigonal planar (d) Trigonal pyramidal
- v) Discuss the difference between a polar and a non-polar covalent bond with examples.
- vi) What do you understand by directional nature of covalent bond?
- vii) What is a multicentre bond. Explain with example.
- viii) Discuss the shape of H_3O^+ .
- ix) Write down the MO electronic configuration of O_2 , O_2^+ and O_2^- and predict the bond order and magnetic behaviour.
- x) Write down Hannay and Smith equation for calculating the percent ionic character of a polar covalent bond. With its help, evaluate percent ionic character present in HCl molecule ($\chi_H = 2.1$, $\chi_{Cl} = 3.0$).

- xi) Draw molecular orbital energy level diagram for NO^+ ion and predict its magnetic behaviour.
- xii) XeF_2 molecule is linear though Xe atom in this molecule undergoes sp^3d hybridisation. Explain.

4.12 ANSWERS

(i) (a) (ii) (b) (iii) (c) (iv) (d)

4.13 REFERENCES

1. Principles of Inorganic Chemistry: B. R. Puri, L.R. Sharma & K. C. Kalia, Milestone Publishers and Distributers, Daryaganj, Delhi (2013).
2. Selected topics in Inorganic Chemistry: W.U. Malik, G.D. Tuli & R.D. Madan, S. Chand & Co. Ltd., New Delhi (1993). Comprehensive Inorganic chemistry: Sulekh Chandra, New Age International (Pvt.) Ltd., New Delhi (2004).
3. The Nature of the Chemical Bond: Linus Pauling, 3rd Edn., Cornell University Press, New York (1960).
4. A Simple Guide to Modern Valency Theory: G.I. Brown, Revised Edn., Longmans Green, London (1967).
5. Advanced Inorganic Chemistry: Satya Prakash, G.D. Tuli, S.K. Basu and R.d. Madan, Vol. I, 7th Edn., S. Chand & Co. Ltd, New Delhi (1998).
6. Shriver and Atkins' Inorganic Chemistry: Peter Atkins *et. al.*, 5th Edn., Oxford University Press, New York (2010).

BLOCK II: ORGANIC REACTION AND STEREOCHEMISTRY

UNIT 5: MECHANISM OF ORGANIC REACTIONS

CONTENTS:

- 5.1 Introduction
- 5.2 Objectives
- 5.3 Curved arrow notation
 - 5.3.1 Drawing electron movements with arrows
 - 5.3.2 Half-headed and double headed arrows
- 5.4 Homolytic and heterolytic bond cleavage
- 5.5 Type of reagents
 - 5.5.1 Nucleophilic Reagents or Nucleophiles
 - 5.5.2 Electrophilic Reagents or Electrophiles
- 5.6 Recapitulation of types of reagents
- 5.7 Reaction intermediates
 - 5.7.1 Carbocations
 - 5.7.2 Carbanions
 - 5.7.3 Free radicals
 - 5.7.4 Carbenes
 - 5.7.5 Nitrenes
 - 5.7.6 Benzyne
- 5.8 Formal charge on intermediates and other ionic species.
- 5.9 Summary
- 5.10 Terminal Questions
- 5.11 Bibliography

5.1 INTRODUCTION

Organic reactions involve breaking and formation of chemical bonds that is the changes in sharing of electrons between atoms in given molecules. Movement of electrons during organic reactions is denoted by curved arrow notations. For example, movement of odd electron is represented by half headed arrow whereas movement of electron pair is

represented by full curved arrows. Understanding the correct arrow notation not only helps to describe how an organic reaction is taking place but also helps to quickly understand the peculiar mechanistic steps involved. Thus, content of this chapter is essential for beginning study of organic reaction mechanisms. Later, the chapter discusses important categories of organic reagents those are useful to carry out particular organic transformations. For example, nucleophilic reagents attack on electron deficient sites in a molecule while the electrophilic reagents react with electron rich species. Thus, this chapter is a suitable package to begin learning and understanding the organic chemistry transformations.

In the Organic Chemistry the reactions takes place in many steps. In these steps the reaction intermediates are also formed which are consumed during the reaction to give the product. So the reaction intermediates are defined as; "A neutral or charge species which is form during the reaction and by consumed gives the final product is known as reaction intermediates. Reaction intermediates are highly reactive because they have strong tendency to convert in stable form and their life period is 10^{-12} sec. A reactive intermediate is a short-lived, high-energy and highly reactive species. It generated in a chemical reaction and it will quickly convert into a more stable product. Only in exceptional cases can these compounds be isolated and stored, e.g. low temperatures, matrix isolation. When their existence is indicated, reactive intermediates can help explain how a chemical reaction takes place.

Most chemical reactions takes place more than one step to complete, and a reactive intermediate is a high-energy, yet stable, product that exists only in one of the intermediate steps. A reactive intermediate differs from a reactant or product or a simple reaction intermediate only in that it cannot usually be isolated but is sometimes observable only through fast spectroscopic methods. It is stable in the sense that an elementary reaction forms the reactive intermediate and the elementary reaction in the next step is needed to destroy it. Reactive intermediates based on carbon are Carbocations, Carbanions, Free radicals, Carbenes, Nirenes and Benzyne.

5.2 OBJECTIVES

After completing this unit learner able to understand the following:

- To know the basics concepts of organic reaction mechanisms like all chemical transformations, breaking and formation of chemical bonds.
- To known about concise detail on type of reagents affecting various organic reactions.

- Explain what a reactive intermediate is, why they are important in organic reactions, and what reaction intermediates are commonly encountered.
- Learn the properties of carbocations, carbanions, carbon radicals, carbenes, nitrenes and benzyne including their structure, hybridization, geometry, and reason for reactivity.
- Learn the hyperconjugation, and how it stabilizes carbocations and carbon radicals.

5.3 CURVED ARROW NOTATION

Chemical reactions involve breaking and formation of chemical bonds. It means sharing of electrons between atoms in given molecules changes during reactions. This change in sharing of electron or movement of electrons is denoted by different types of curved arrows depending on the reactions. For example, movement of odd electron (or single electron) is represented by half headed arrow whereas movement of an electron pair is represented by double headed curved arrows. How a double-headed or full-headed arrow and half-headed or fish-hook arrow is drawn in organic chemistry is depicted in Figure 5.1.

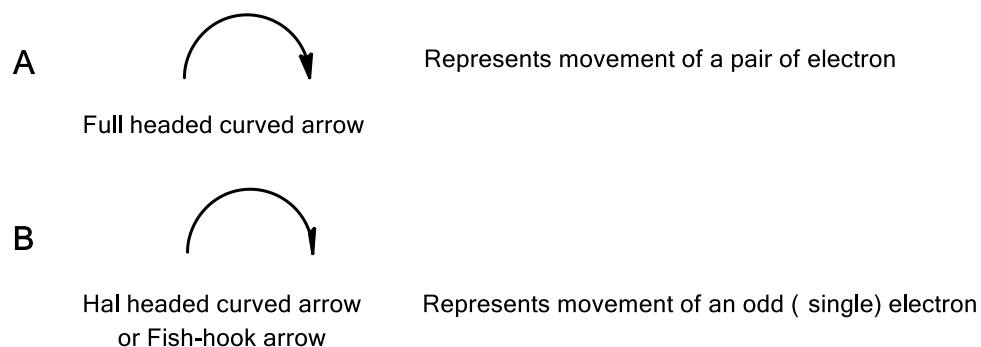

Figure 5.1 Depiction of full (A) and half (B) headed arrows

5.3.1 Drawing electron movements with arrows

Occurrence of electron movement in organic reactions or during the inter-conversion of resonating structures is obvious in organic chemistry. As the organic reactions proceed through several steps, it is important to keep track of electron movements taking place in each step to swiftly understand the mechanistic aspects. The electron movements are denoted by curved arrows as depicted in previous section. The distinct curved arrows should not be confused with other common straight arrow notations in organic chemistry. Arrow head indicates the location where electrons are moving to and the arrow tail indicates where

originally electrons were located. Double headed and half headed curved arrows are discussed with some examples in the next section.

5.3.2 Half-headed and double headed arrows

Half headed arrows also referred as fish hook arrows are used to denote the movement of odd electron from one reaction site to another. Since they represent movement of single electron (odd electron) therefore, they are frequently used to depict reactions involving free radicals. Thus, mechanism of homolytic fission, reactions involving free radicals and photochemical reactions are demonstrated by half headed or fish hook arrows. Some examples are depicted in the Figure 5.2.

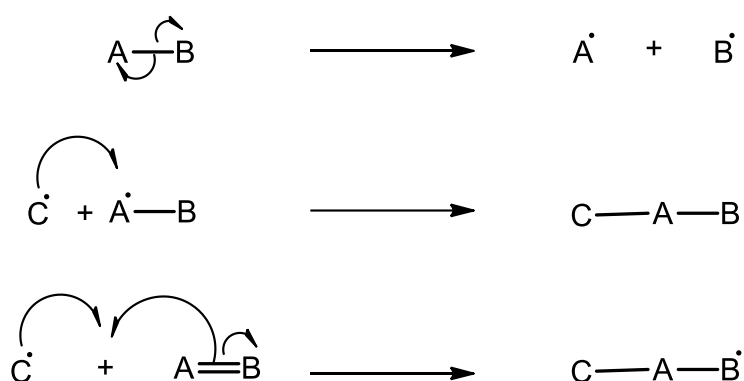

Figure 5.2 Movement of odd electrons in some processes is depicted by half headed arrows. Note the movement of electron and resulting molecular or radical species.

The first reaction indicates homolytic fission of covalent bond between atoms A and B that results in formation of free radicals $A\cdot$ and $B\cdot$. Tail of half headed arrows is on bond which is the original position of electrons and the arrow heads are pointing to the atoms A and B where the electrons locate on completion of the process. In the second example, equal sharing of odd electrons between free radicals, $C\cdot$ and $\cdot A-B$ results in a molecule C-A-B. The third example illustrates hemolytic breaking of a π bond as a result of attack by radical $C\cdot$. C and A equally share one electron each to form new σ bond between them, whereas one odd electron resides on atom B.

Double headed arrows are used to denote the movement of electron pair from one reaction site to another. This type of arrows frequently used to depict ionic reaction mechanisms. Arrow tail and arrow head indicate initial and final locations of electron pairs respectively. Some examples are depicted in the Figure 5.3.

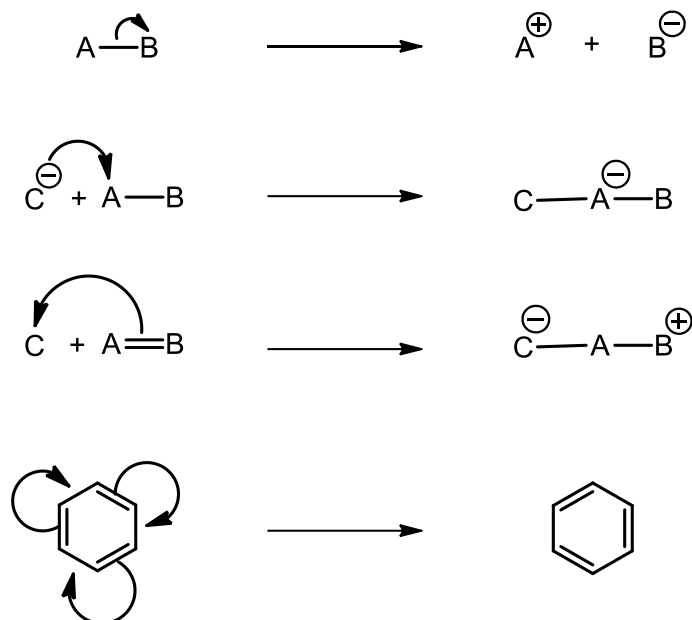

Figure 5.3 Movement of electron pairs in some processes as depicted by full headed arrows. Note the movement of electron pairs and resulting molecular or ionic species.

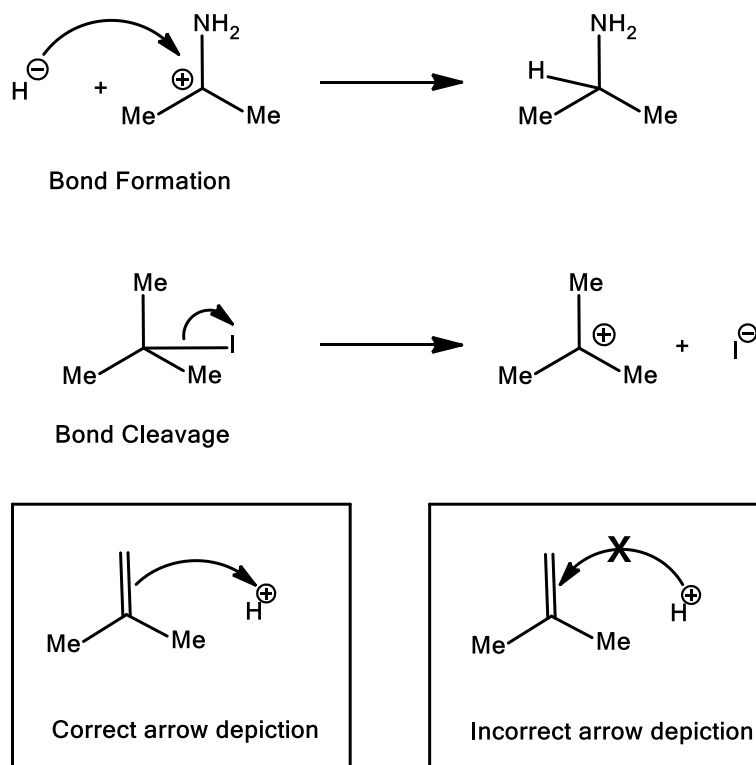

Figure 5.4 Correct depiction of curved arrow for formation and breaking of covalent bond. Inset images show correct and incorrect way to depict electron movement with curved arrows.

The first reaction indicates heterolytic fission of covalent bond that results in formation of ions A^+ and B^- . In the second example, anion C^- attacks on electron deficient site A in a molecule A-B, i.e., C^- donates electron pair to atom A in molecule A-B resulting in the anion on product side. Third example involves attack of electron deficient atom C on the electron rich site, i.e., π bond between A and B. In the resultant species atom C assumes formal negative charge because it accepts additional electron in its orbital whereas atom B loses its electron, hence the formal positive charge on B. Fourth example depicts the concerted movement of three π electron pairs in benzene ring that inter-converts two Kekulé structures into each other.

5.4 HOMOLYTIC AND HETEROLYTIC BOND CLEAVAGE

Chemical reactions involve breaking and formation of chemical bonds. How a chemical bond will break depends on factors such as temperature, reaction medium and solvent. Organic reactions usually involve breaking of covalent bonds followed by formation of new covalent bonds. The bond breaking, also termed as bond cleavage takes place in two possible ways, namely, homolytic and heterolytic bond fission.

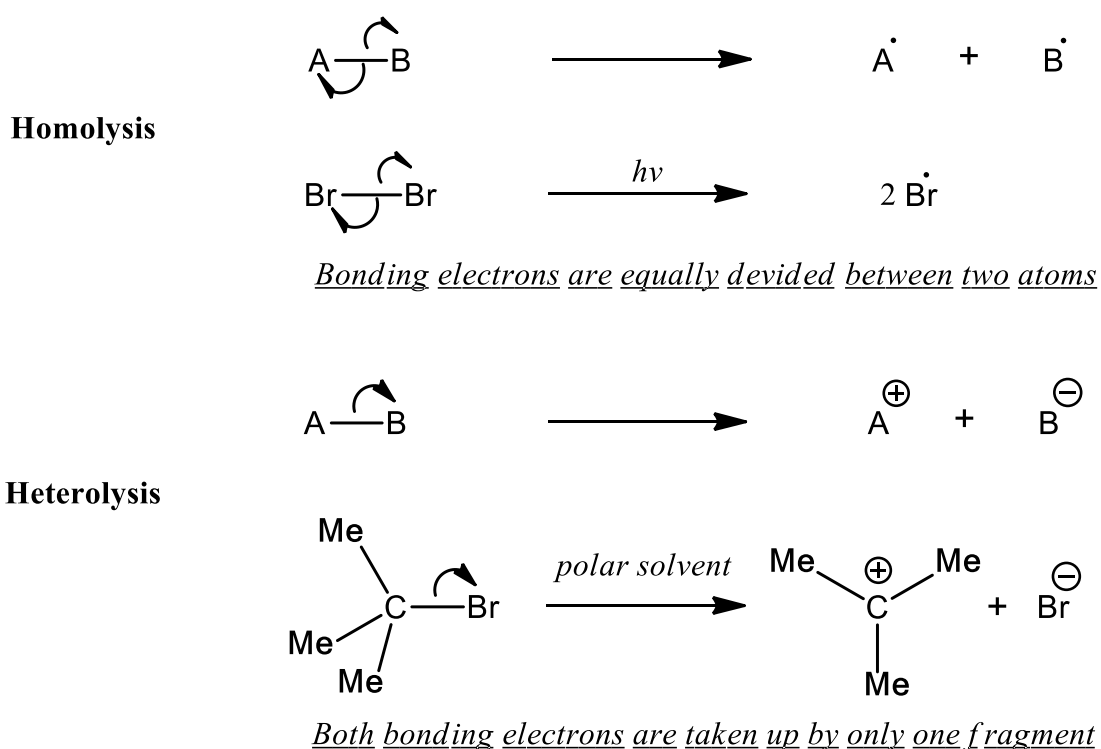

Figure 5.5 General and specific examples depicting homolysis and heterolysis of covalent bonds.

Homolytic bond cleavage is also called homolytic bond fission or homolysis. In homolysis, the two electrons in a cleaved covalent bond are divided equally between the products. On the other hand, heterolytic bond cleavage is also called heterolytic bond fission or heterolysis. In heterolysis, the two electrons in a cleaved covalent bond remain with one of the two fragments.

5.5 TYPE OF REAGENTS

Organic reactions are generally brought about by heterolysis of organic compounds. The breaking of bonds and formation of new bonds occur in presence of reagents. Thus reagents are substances or compounds that are added to bring about a reaction. In organic reactions it is convenient to call one reactant as substrate which will provide carbon to a new bond and the other is called as reagent. The attacking reagent can be (i) which provides an electron pair to the substrate, known as Nucleophile and the reaction is called a Nucleophilic reaction (ii) takes an electron pair from substrate is known as Electrophile and the reaction is called a Electrophilic reaction.

In reactions where the substrate bond is cleaved, the part that does not contain the carbon is called Leaving group. The leaving group that carries electron pair is known as Nucleofuge. If the leaving group moves out without the electron pair, it is called Electrofuge.

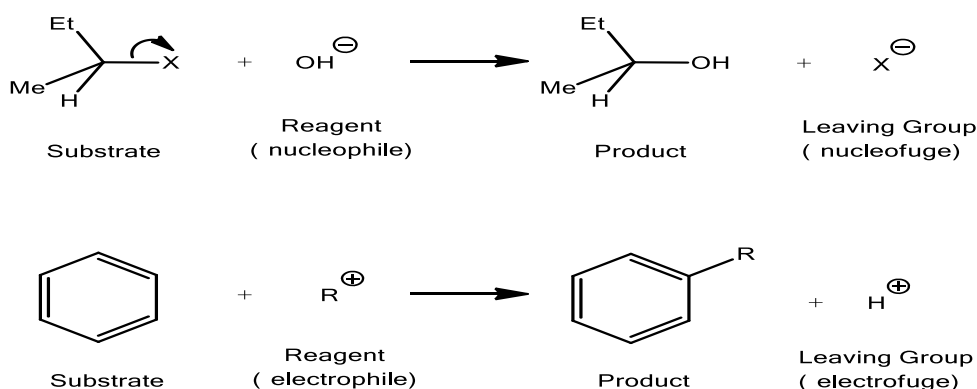

5.5.1 Nucleophilic Reagents or Nucleophiles

Nucleophile means nucleus loving. Reagents having unshared pair of electrons are known as Nucleophilic reagents or nucleophiles and they show tendency to share this lone pair of electrons with electron deficient species. They can be classified into three groups:

(i) Neutral Nucleophiles: These are electron rich species due to presence of non bonding pair of electrons. Central atom of such species should have a complete octet. Neutral nucleophiles are not charged and are electrically neutral.

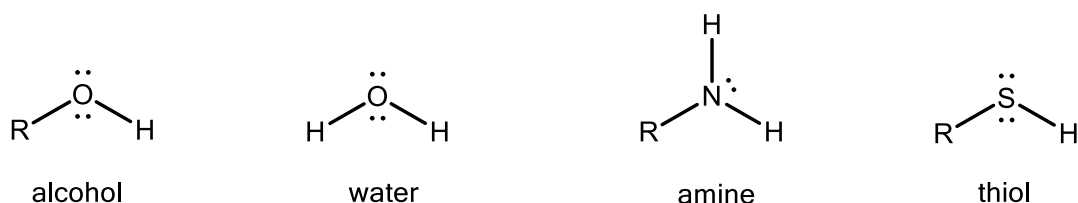

Organic compounds having C-C multiple bond/bonds also act as Neutral nucleophiles because these species have π electron cloud above and below the plane of the molecule. The addition reaction of a neutral nucleophile to a positively charged substrate gives a positively charged product.

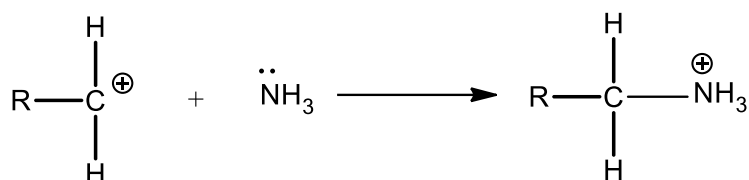

(ii) Negative Nucleophiles: These carry an electron pair and are negatively charged because of the presence of unpaired electrons.

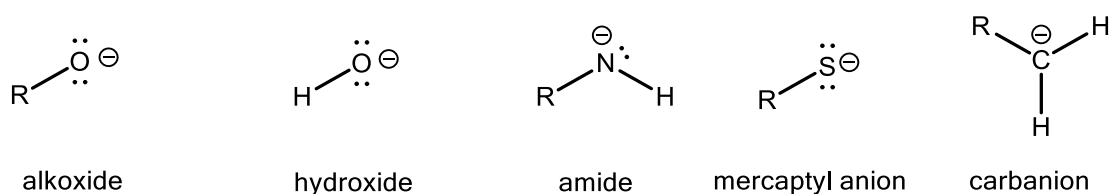

Addition reaction of a negatively charged nucleophile to a positively charged substrate results in neutral molecule.

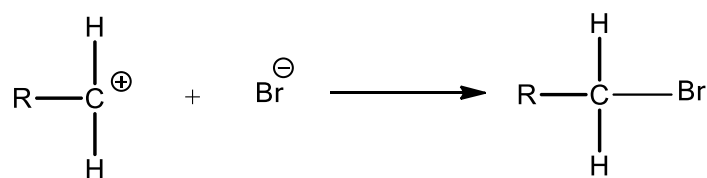

(iii) Ambident Nucleophiles: The nucleophiles which can attack through two or more atoms are called ambident nucleophiles. For Eg: CN^- can attack through N or C to give cyanide (RCN) or isocyanide (RNC) respectively.

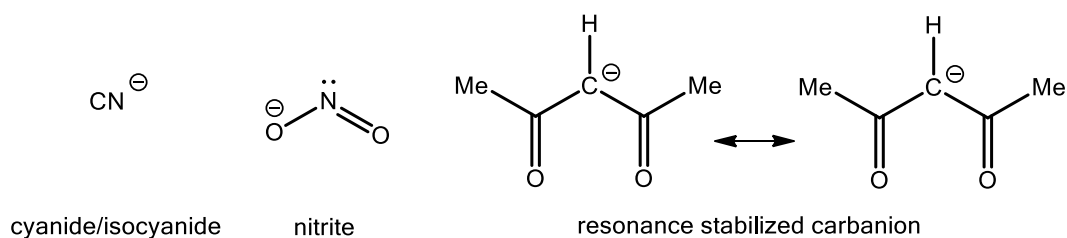

Nucleophiles can also be classified on the basis of the kind of atom that forms a new covalent bond. The most common nucleophiles on this basis are oxygen, nitrogen, sulfur, halogen and carbon nucleophiles.

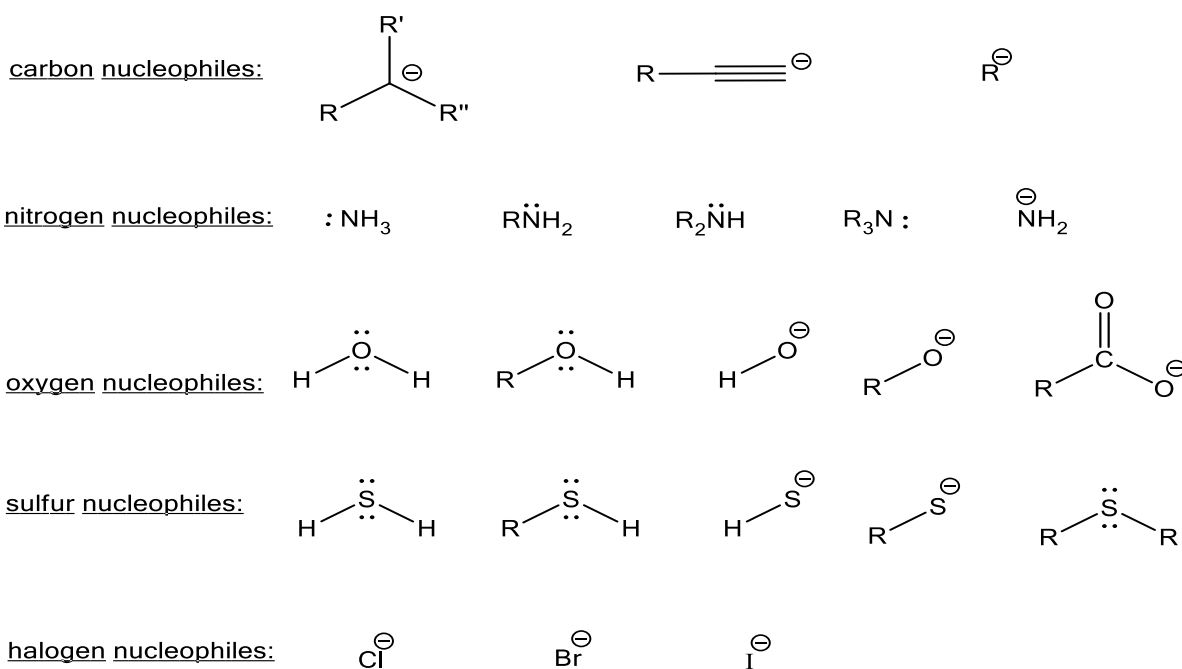

5.5.2 Electrophilic Reagents or Electrophiles

An electrophile (meaning electron loving) is a reagent that is electron deficient and due to this they show affinity for electrons. Electrophiles can also be of two types:

(i) Neutral Electrophiles: These electrophiles even though electron deficient does not carry positive charge. They have incomplete valence shells. Examples: AlCl_3 , BF_3 , carbene etc.

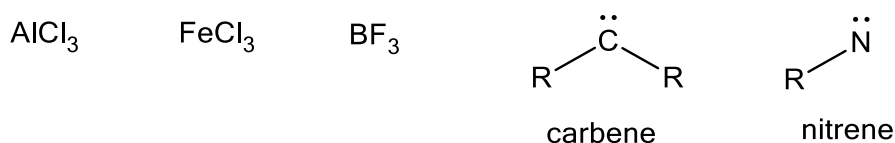

(ii) Positive Electrophiles: These electrophiles carry positive charge on central atom and have incomplete octet.

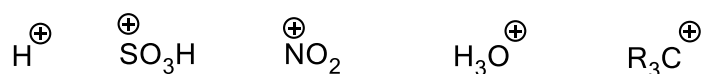

The positive electrophile will attack the substrate (which is a negative nucleophile) and accepts an electron pair for sharing resulting in a neutral molecule. While, a neutral

electrophile will attack a electron rich substrate (negative nucleophile) to form a negatively charged molecule.

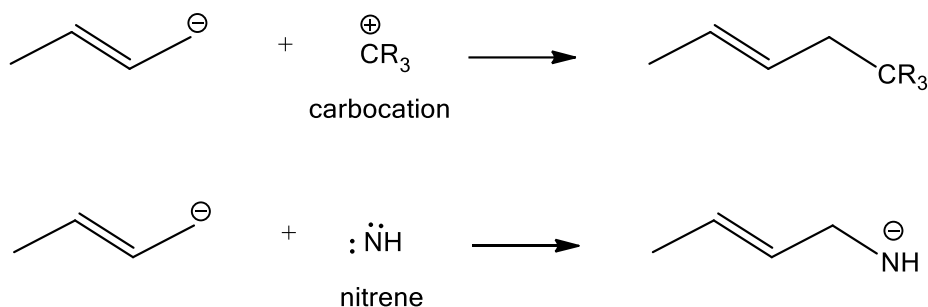

5.6 RECAPITULATION OF TYPES OF REAGENTS

A nucleophile is a chemical species that donates an electron pair to an electron deficient reaction site to form a chemical bond. As the nucleophile donate electrons, they are Lewis bases. All molecules or ions with a free pair of electrons or at least one pi bond can act as nucleophiles. A nucleophile with higher affinity to the electron deficient site is said to have higher nucleophilicity. All carbanions, OH⁻, Br⁻, I⁻ and SH⁻ are few of the good nucleophiles in organic chemistry. Nucleophilic character of similar species comprising different elements increases top to down and decreases on moving left to right in the periodic table. Therefore, SH⁻ is better nucleophile than OH⁻ and CH₃⁻ is better nucleophile than NH₂⁻. Neutral nucleophilic reactions with solvents such as alcohols and water are named solvolysis. Nucleophiles may take part in nucleophilic substitution, whereby a nucleophile becomes attracted to a full or partial positive charge.

On the other hand, an electrophile is a reagent that attracts towards electrons. Electrophiles are positively charged or neutral species having vacant orbitals that are attracted to an electron rich centre. Thus, they are Lewis acids. In chemical reactions, electrophiles accept an electron pair make bond to the electron rich reaction site. Cations such as H⁺ and NO⁺, polar molecules such as HCl, alkyl halide (R-X), acyl halides (R-COX), carbonyl compounds (R-CO-R or R-CHO) and polarizable molecules such as Br₂ and Cl₂ etc are commonly used electrophiles

5.7 REACTION INTERMEDIATES

5.7.1 Carbocations

An Organic species which has a carbon atom containing only six electrons in its outermost shell and has a positive charge is called a carbocation reaction intermediate. The carbon atom of the carbocation is sp² hybridized, it use the three hybrid orbitals for single bonding to three

substituents and remaining p-orbital is empty. The carbocations thus have a planar structure having all the three covalent bonds in a plane with the bond angle of 120° between them.

It is generated by heterolytic bond fission and it carries a positive charge in its structure with six valence electrons. It is known as a carbocation or carbonium ion.

Examples: CH_3^+ , C_2H_5^+ , C_3H_7^+ etc.

Classification of carbonium ion:

A. Alkyl Carbonium ion: Like free radical carbonyl ion also classified into three classes-

1. Primary carbonium ion: In this type of carbonium ion one carbon atom is attached with the positive carbon atom.

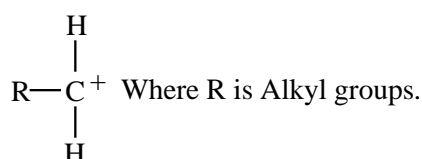

2. Secondary carbonium ion: In this type of carbonium ion two H atoms are replaced by two alkyl groups from the positive charge bearing carbon.

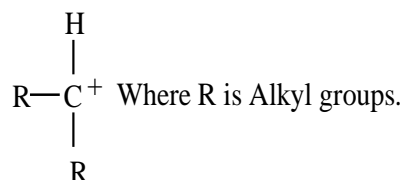

3. Tertiary carbonium ion

In this type of carbonium ion 3 hydrogen atoms are replaced by 3 alkyl groups from the positive charge bearing carbon.

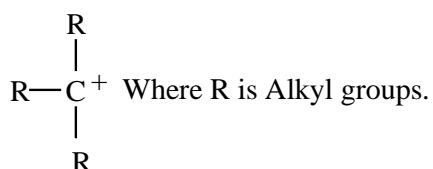

tert. Butyl carbonium ion

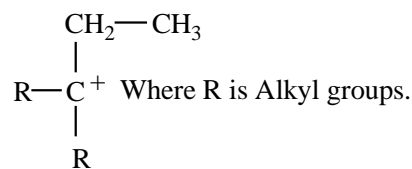

tert. Butyl carbonium ion

Stability of carbonium ion:

The relative stability of carbonium ion is explained with the help of Inductive effect. In the case of 1° carbonium ion the CH_3 group contains +I effect, so it releases the e^- towards the

carbon that bearing +ve charge. So some charge neutralize and also somewhat +ve charge created on the methyl group carbon, so the + charge become dispersed and gives the stability. Hence we can say that greater is the dispersed is the + ve charge greater will be the stability. Hence 3° carbocation is most stable in compare to 2° , 1° and methyl cabocation.

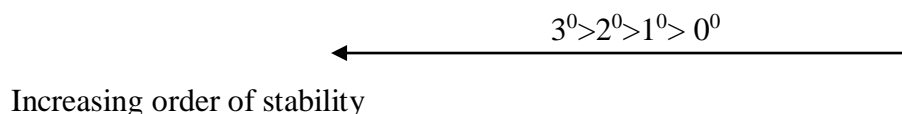

5.7.2 Carbanions

These are chemical species which possess a negatively charged carbon centre. Like the Carbocations the Carbanions are also formed by *hetertolytic fission* of covalent C-Y molecules.

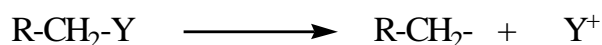

Here Y is an atom which is more electropositive than carbon. This is why during the heterolytic fission the shared pair of electrons is drawn towards the carbon atom to develop a negative charge over it. It is generated by heterolytic fission and bearing -ve charge and the number of valence electrons are 8 in it called carbanion reaction intermediate.

Example:

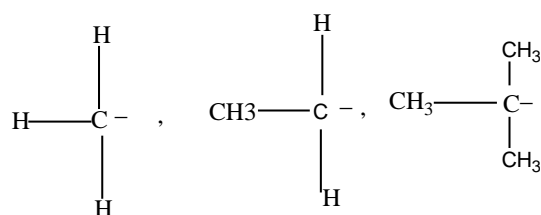

Hybridization in carbanion ion:

The carbanion ion shows sp^3 hybridization with one loan pair of electron. Hence its geometry will be tetrahedral.

E.g.

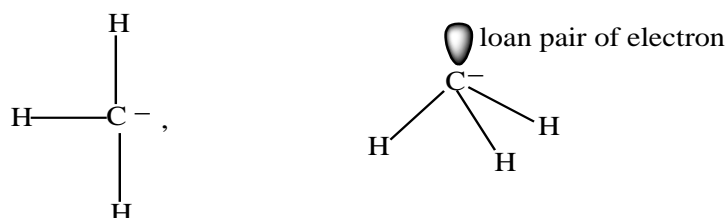

Classification of Carbonium ion:

Like carbocation, carbonion ion are also classified in to three classes and it is depends upon the replacing of H from the bearing C. If only 1 H is replaced then it is primary, if two H are replaced then it is secondary, if 3 H is replaced then it is tertiary.

e.g.

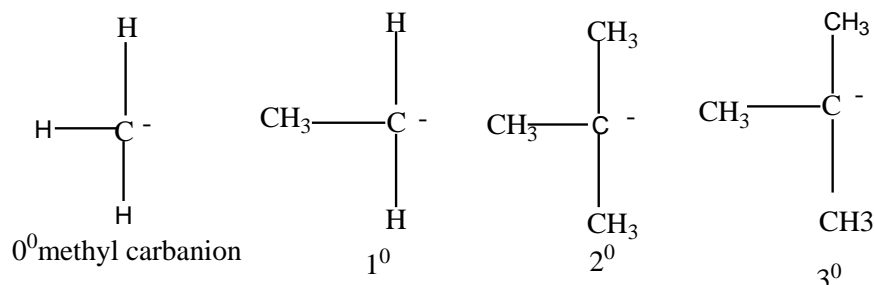
**Stability of carbonian ion:**

The stability of carbonian ion is reverse to the stability of carbocation and free radical. Hence the order of the stability is:

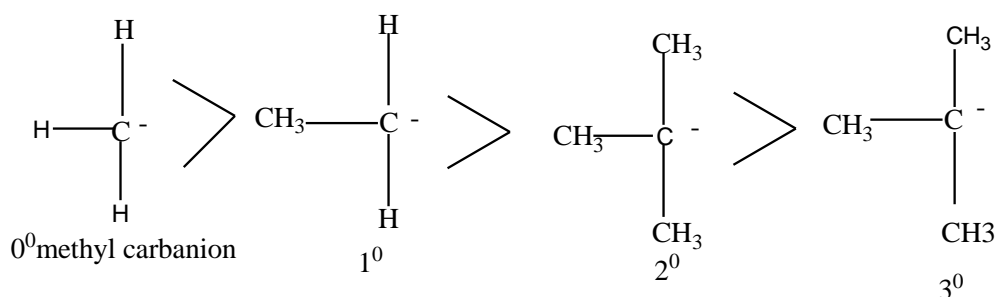

Decreasing order of stability of carbonian ion.

Cause: Since $-\text{CH}_3$ group consist +I affect, so it increases the density of e^- on the carbonian ion. Hence its result is destabilization. So we can say that on increasing the I effect stability decreases. Thus the result 0° carbonian is most stable in compare to $1^\circ, 2^\circ$ and 3° carbonian.

5.7.3 Free radicals

These are species which are atoms or groups of atoms containing unpaired electrons. They are formed by the *homolytic fission* of covalent bond.



Example: CH_3^\bullet , $\text{CH}_3\text{CH}_2^\bullet$, H^\bullet etc.

The free radicals are strongly reactive because they have stronger tendency to become paired and their nature is paramagnetic.

Hybridization in free radical:

Free radical shows sp^2 hybridization and their geometry is triangular.

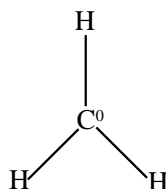

Classification of free radical:

Free radicals are classified in two following three types-

1. Primary free radicals: When 1 H atom of $-\text{CH}_3$ group is replaced by another alkyl group then it is called as 1° free radical.

E.g.

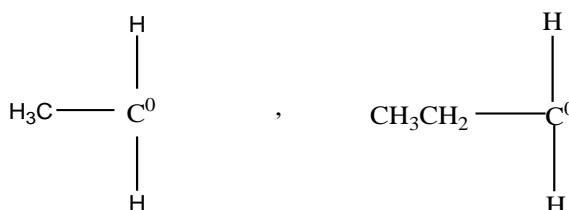

2. Secondary free radical: When 2 H atom of $-\text{CH}_3$ group is replaced by another alkyl group then it is called as secondary free radical.

Eg :

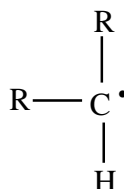

3. Tertiary free radical: When 3H atom of $-\text{CH}_3$ group is replaced by another alkyl group then it is called as tertiary free radical (3°).

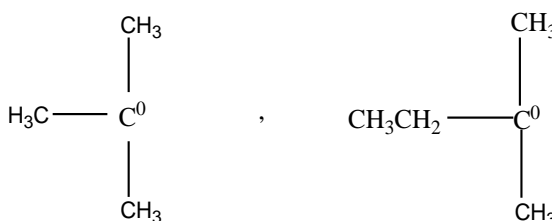

Stability of free radical:

The relative stability of free radical is explained with the help of hyperconjugation concept. If the alkyl chain is longer, attached to that carbon which bears (carrying) odd electron then there is the maximum delocalization in the odd electron, hence it becomes most stable. Similarly secondary radical has more delocalization than primary free radical. So finally it is clear that tertiary free radical is most stable in compare to 2° , 1° and 0° free radicals.

5.7.4 Carbenes

Carbenes are neutral, divalent, highly reactive intermediate carbon species. It is defined as a neutral reactive divalent species which consist six electrons in its outermost shell is known as Carbene.

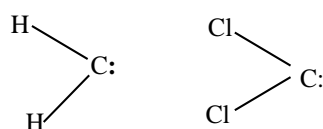

Carbenes are highly reactive because they have stronger tendency to complete their octate.

Methods of preparation:

1. From diazomethane-Diazomethane on decomposition under the action of light gives carbene.

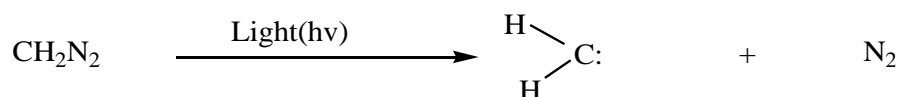

2. From chloroform: Chloroform on react with sodium ethoxide gives dichloro carbene by releasing $\text{C}_2\text{H}_5\text{OH}$.

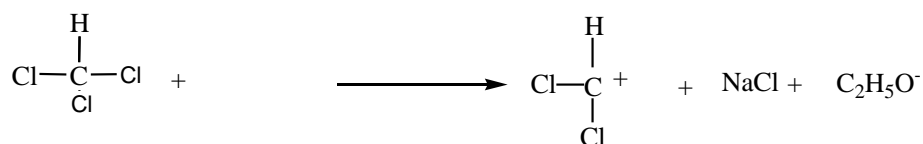
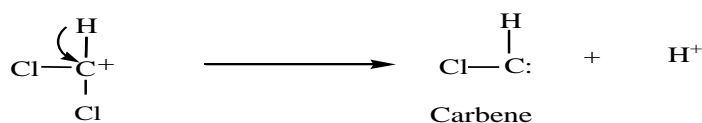
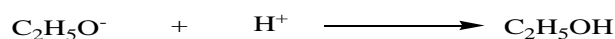
Step 1**Step 2****Step 3**

Properties of carbene:

Carbene is a highly reactive reaction intermediate and it gives easily reaction.

1. Reaction with Alkene: carbene on react alkene gives cycloalkanes.

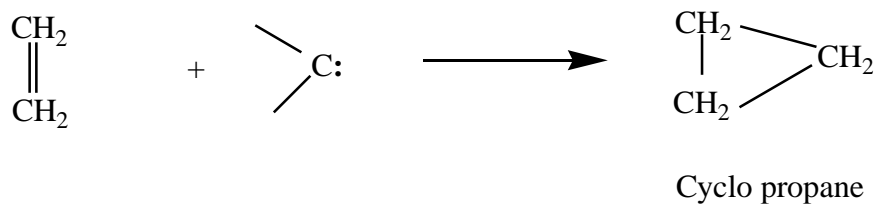

e.g.

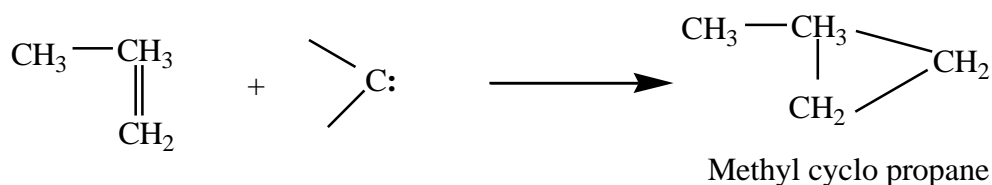

2. Reaction with alcohol: Carbene on react with alcohol gives addition compound ether.

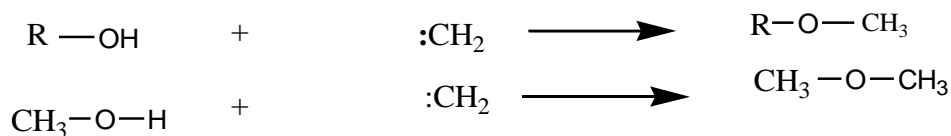

3. Insertion Reaction: In this reaction carbene react with those functional groups which are bi-valent and from both sides they are link with another groups undergoes insertion reaction with carbene.

Note: ketone on react with carbene gives higher member of ketone.

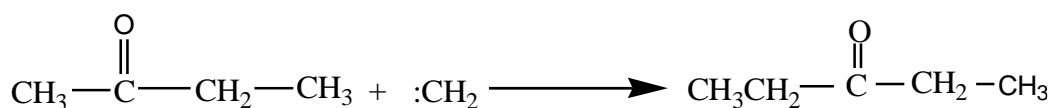
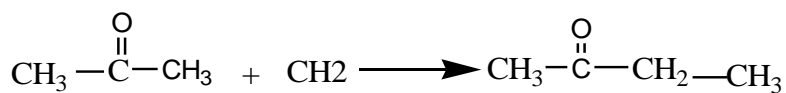

4. Reaction with alkanes: Alkanes on react with carbene gives higher number of alkane series.

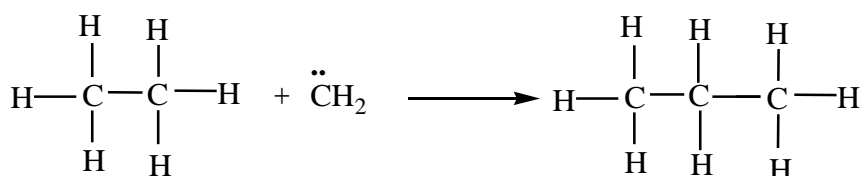

Classification of carbene: Carbenes are classified in to two classes by name these are-

1. Singlet carbene
2. Triplet carbene

1. **Singlet carbene:** In this type of carbene sp^2 hybridization is observed and the unshared pair of electron is present in one p- orbital.

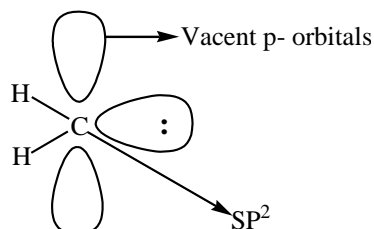

$$\text{Multiplicity} = S = 1/2n$$

(Where n is the number of unpaired electron)

In this case $n = 0$

$$\text{Since multiplicity} = 2s + 1$$

$$= 2 \times 0 + 1$$

$$= 1 \text{ (singlet)}$$

3. **Triplet carbene:** In this type of carbene the unshared pair of electron is exist in to two unhybridised p- orbital. So they show sp- hybridization with linear geometry.

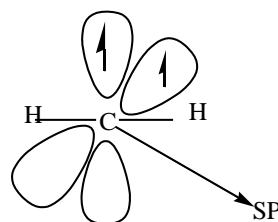

$$S = \frac{1}{2} n$$

$$S = \frac{1}{2} \times 2$$

$$S = 1$$

$$\text{Since multiplicity} = 2s + 1$$

$$= 2 \times 1 + 1 = 3 \text{ (Triplet)}$$

Stability of singlet and triplet carbene: Triplet carbene is more stable because in singlet carbene there is the repulsion between unshared electrons.

5.7.5 Nitrenes:

Nitrenes are defined as “A neutral reactive monovalent species which consist six electrons in its outermost shell is known as nitrene”. The nomenclature follows that of carbene. Substituted nitrenes are simply named as substituted derivative of carbene. For example:

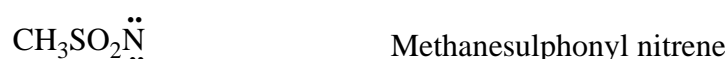

In nitrenes the nitrogen atom N has one lone pair of electron and one unshared pair of electron.

Method of preparation:

1. **From hydrazoic acid-** Hydrazoic acid (HN_3) on decomposition gives nitrene.

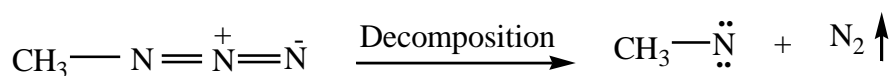
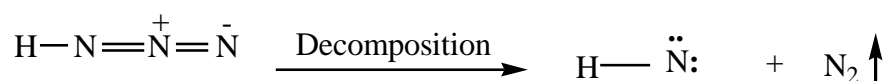

2. **From Ammonia:** Ammonia (NH_3) on decomposition gives nitrene by removing H_2 gas.

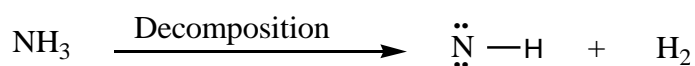

3. **From hydrazine:** Hydrazine on decomposition gives nitrene.

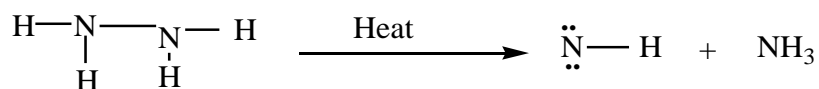

Properties: Nitrenes are highly reactive because they have stronger tendency to complete their octate.

1. **Insertion reaction:** In this type of reaction nitrene react with alkane to give amino derivative compound.

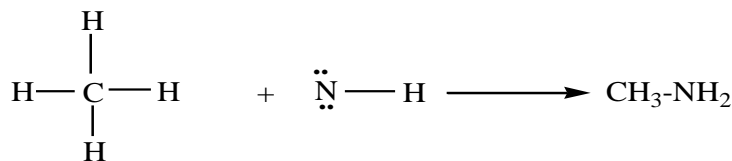

Aminomethane

2. **Reaction with alkene:** Nitrene on react with alkenes gives cyclic amino compounds.

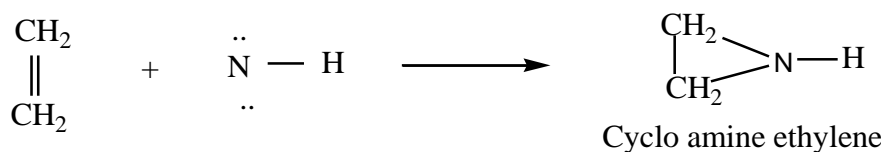

3. **Dimerization reaction:** In this type of reaction two nitrenes are combined together to form the product.

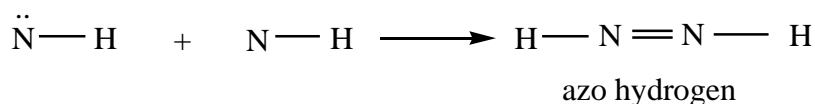

Classification of nitrenes: Nitrenes are classified into two classes one is singlet and other is triplet nitene.

1. **Singlet nitrene:** In this type of nitrene the unshared pair of electron is present in one p-orbital and it consist sp^2 hybridization, its geometry is as follow.

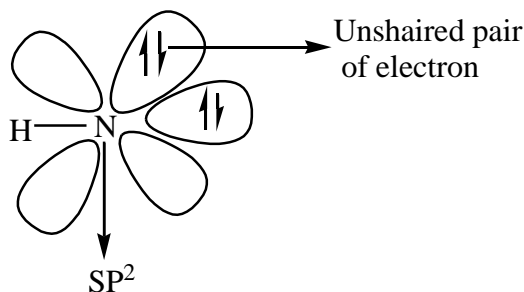

For multiplicity:

Unshaired pair of e^- $n = 0$

$$S = \frac{1}{2} n = \frac{1}{2} \times 0 = 0$$

Since multiplicity = $2s + 1$

$$= 2 \times 0 + 1 = 1 \text{ (singlet)}$$

2. **Triplet nitrene:** In this type of nitrene N atom shows sp hybridization and the unshared electron are present in two different p -orbitals.

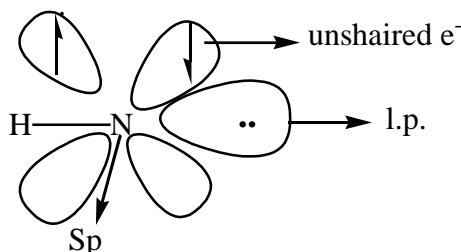

For multiplicity: No. of unpaired e^- ($n=2$)

$$s = \frac{1}{2} n = \frac{1}{2} \times 2 = 1$$

So multiplicity = $2s + 1$

$$= 2 \times 1 + 1$$

$$= 3 \text{ (Triplet)}$$

5.7.6 Benzyne:

Benzyne or aryne are highly reactive species derived from an aromatic ring by removal of two ortho substituents. Arynes are usually best described as having a strained triple bond; however, they possess some biradical character as well.

The aryne nomenclature derives from the fact that the C_6H_4 can be represented as an alkyne, although systematically the species should be named as didehydro aromatic compounds, i.e. 1,2-didehydrobenzene.

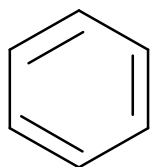

Benzyne can be represented as a singlet molecule with a carbon-carbon triple bond. Although it has triple bond but it is not normal alkyne bond. In benzyne out of two π -bond of triple bond, one π -bond is normal and the other π -bond is abnormal and is formed by overlap of two sp^2 orbitals outside the ring. This is called external π -bond. It can be represented as follow.

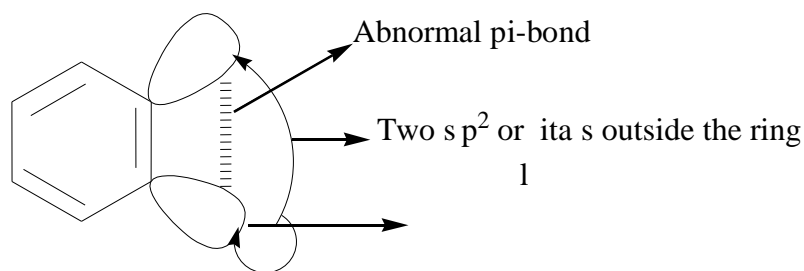

Preparation of benzyne:

- 1. From halobenzene:** When halobenzene are react with sodamide in liquid ammonia then it gives benzyne.

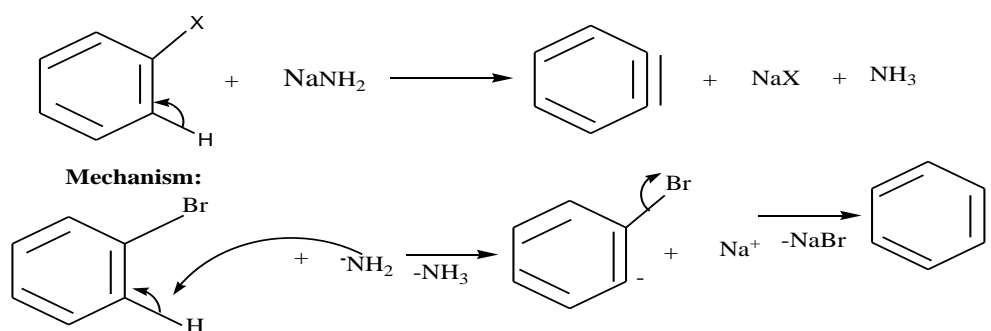

- 2. From *o*-dihalobenzene:** When *o*-dihalobenzene is treated with lithium amalgam or Mg, then it gives benzyne.

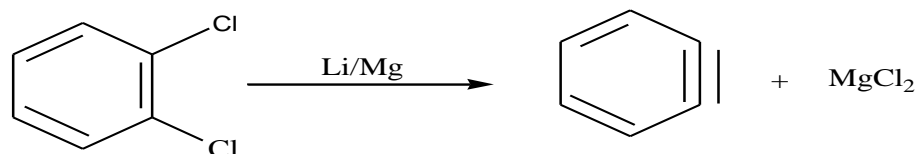

- 3. From benzenediazonium-2-carboxylic acid:** benzenediazonium-2-carboxylic acid when heated in the presence of heat and sun light then it gives benzyne.

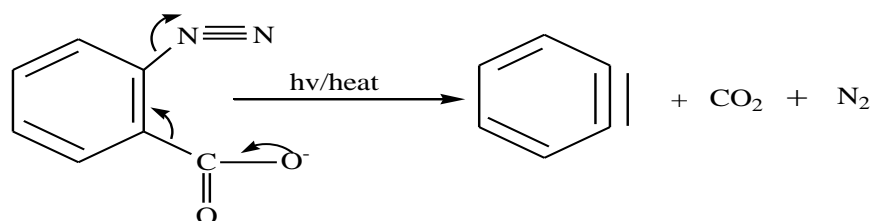

5.8 FORMAL CHARGE ON INTERMEDIATES AND OTHER IONIC SPECIES

The formal charge of an atom in a polyatomic molecule or ion may be defined as the difference between the number of valence electrons of that atom in an isolated or free State and the number of electrons assigned to that atom in the Lewis structure. It is expressed as:

$$\text{Formal Charge} = \text{Number of valence electron} - \text{Number of unshared electron} - \frac{1}{2} \text{Number of electrons shared in covalent bond}$$

$$\left[\begin{array}{l} \text{Formal charge (F.C.)} \\ \text{on an atom in a Lewis} \\ \text{structure} \end{array} \right] = \left[\begin{array}{l} \text{total number of valence} \\ \text{electrons in the free atom} \end{array} \right] - \left[\begin{array}{l} \text{total number of non} \\ \text{bonding (lone pair)} \\ \text{electrons} \end{array} \right] - \left[\begin{array}{l} (1/2) \text{ total number of} \\ \text{bonding (shared)} \\ \text{electrons} \end{array} \right]$$

Procedure: The procedure to determine formal charges on the atoms of an ion or molecule has three steps. The process is illustrated using hydronium ion (H_3O^+); an ion very frequently encountered in organic and biochemical reaction mechanisms.

Step 1: Draw the best Lewis structure for the molecule, including all unpaired electrons.

Be sure to show all non bonded electrons, as these influence formal charges. The best Lewis structure for the hydronium ion is shown below. The brackets indicate the positive charge belongs to the entire molecule.

Step 2. Assign the formal charge to each atom.

Formal charge is calculated using this formula:

$$\text{Formal Charge} = \text{Number of valence electron} - \text{Number of unshared electron} - \frac{1}{2} \text{Number of electrons shared in covalent bond}$$

Step 3. Check your work.

The sum of the formal charges of all atoms must equal the overall charge on the structure. For example hydronium ion, the sum of the formal charges on the hydrogen atoms (3 x zero) plus one for the oxygen gives a total charge of +1, which agrees with the overall charge.

Let us consider the ozone molecule (O_3). The Lewis structure of O_3 may be drawn as :

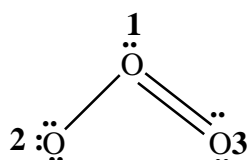

The atoms have been numbered as 1, 2 and 3. The formal charge on:

- The central O atom marked 1

$$= 6 - 2 - 1/2 (6) = +1$$

- The end O atom marked 3

$$= 6 - 4 - 1/2 (4) = 0$$

- The end O atom marked 2

$$= 6 - 6 - 1/2 (2) = -1$$

Hence, we represent O₃ along with the formal charges as follows:

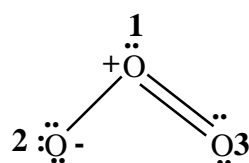

5.9 SUMMARY

This chapter covers description of basic concepts such as curved arrow notation (arrow pushing) and bond fission, which are vital to understand and write organic reaction mechanisms. The description on topics such as full headed & half headed curved arrow, nucleophiles and electrophiles, homolytic and heterolytic bond fission is given in the chapter with sufficient details. Other significantly important terms such as nucleofuge, electrofuge, leaving group, substrate and attacking reagents are given with guiding figures. Understanding of these topics will help us to understand and gain interest in mechanisms of organic reactions.

5.10 TERMINAL QUESTIONS

Q.1 Short Answer type questions

1. Briefly describe the curved arrow notation for movement of odd electrons.
2. Describe the full headed curved arrow notation used in reaction mechanisms.
3. What is an electrofuge? Give two examples of electrofuge.
4. Write short note on heterolysis of covalent bonds.
5. Describe the terms substrate, reagent and leaving group.

6. Discuss neutral nitrogen containing nucleophiles.
7. What is the difference between nucleophile and electrophile?
8. Give one example of a nucleophilic and an electrophilic substrate.
9. What are carbanion? How they are generated? Discuss their stability order.
10. What are Carbenes? How they are generated? Give the structure of Singlet and Triplet carbenes.
11. Discuss some reactions of benzyne.
12. What are benzyne? Give their structure.
13. What are Singlet and Triplet nitrenes?
14. Give the Relative stability of free radicals with the help of hyperconjugation effect.
15. Give the relative stability of the alkyl carbo cations.
16. What are the important factors affecting the stability of carbanions? Discuss the structure of carbanions.
17. How will you distinguish between singlet and triplet carbenes based on their stability and stereochemical behaviour in addition reactions?
18. Explain the structure and stability of carbon free radicals
19. Complete the following reactions:

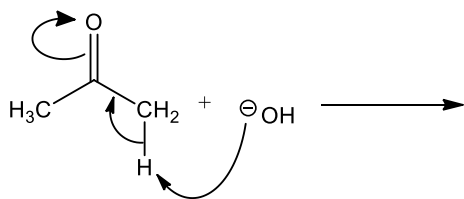
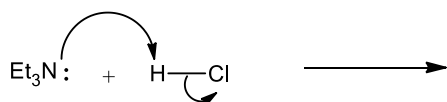
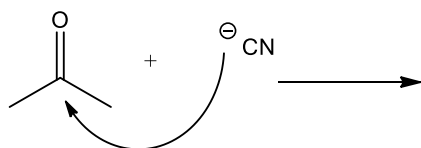

20. Place the appropriate curved arrows to depict the electronic movement in following reactions.

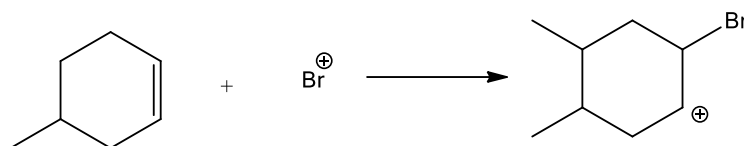
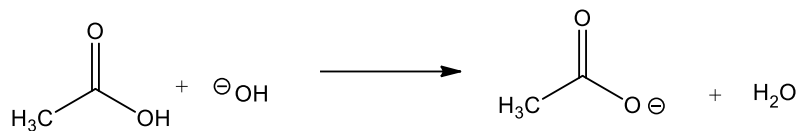

Q.2 MCQ type questions

1. Identify the correct arrow depicting movement of electron pair in organic reaction mechanisms:

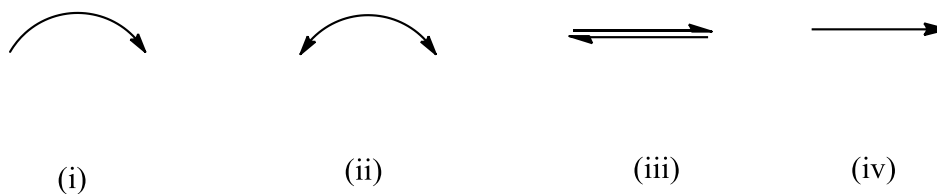

- (a) iii
 (b) i
 (c) iv
 (d) ii

2. Select from the options given below the electrophilic species:

- (a) SO_3
 (b) $\text{H}_3\text{C}-\overset{\oplus}{\text{C}}\text{H}_2$
 (c) BF_3
 (d) both b and c

3. Which one of the following represents movement of odd electron in organic reaction mechanisms:

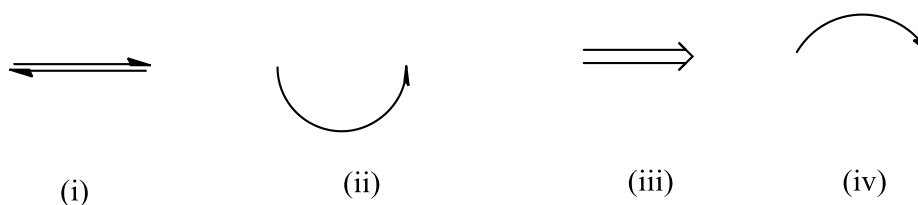

- (a) iii
- (b) i
- (c) iv
- (d) ii

4. Select from the options given below the nucleophilic species:

- (a) $\ominus\text{CCl}_3$
- (b) LiAlH_4
- (c) $\text{H}_3\text{C}-\text{O}-\text{CH}_3$
- (d) all of the above

5. Find the correct depiction for fish-hook arrow:

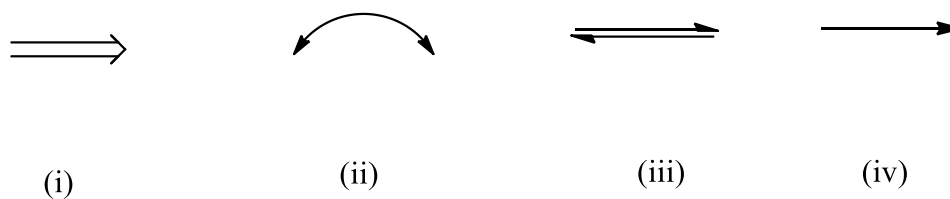

- (a) ii & iii
- (b) iii
- (c) none
- (d) i

6. Identify the electrophile from the following options:

- (a) CO_2
- (b) SO_3
- (c) AlCl_3
- (d) Both a and b

7. A leaving group is called so because:

- (a) it detaches from the carbon in organic reaction
- (b) it detaches from the attacking reagent
- (c) it is part of incoming nucleophile
- (d) it is part of incoming electrophile

8. Which of the species given below behaves as ambident nucleophile:

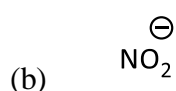
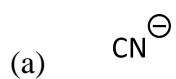

- (d) Both a and b

9. Which of the species given below is an ambident nucleophile:

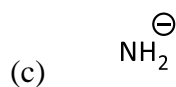
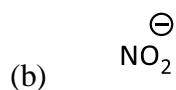
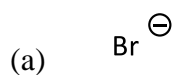

- (d) All of the above

10. Nucleofuge and Electrofuge are commonly called as:

- (a) substrate
- (b) leaving group
- (c) incoming group
- (d) attacking reagent

ANSWERS

Q.1 Answers to the short answer type questions

19.

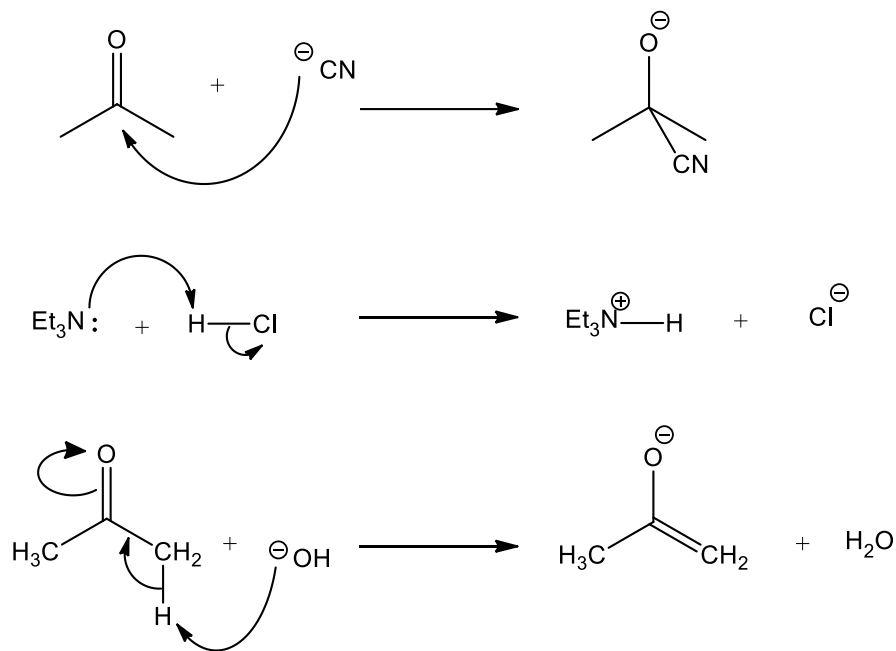

20.

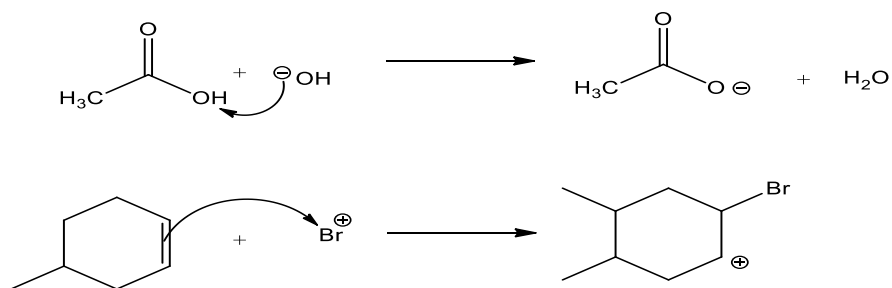

Q.2 Answers to the MCQ type questions

- | | | | | | | | | | |
|----|-----|----|-----|----|-----|----|-----|-----|-----|
| 1. | (a) | 2. | (d) | 3. | (b) | 4. | (d) | 5. | (c) |
| 6. | (c) | 7. | (a) | 8. | (d) | 9. | (b) | 10. | (b) |

5.11 BIOBLIOGRAPHY

1. Clayden, Jonathan; Greeves, Nick; Warren, Stuart; Wothers, Peter (2001). Organic Chemistry (1st ed.). Oxford University Press.
2. Daniel E. Levy, Arrow Pushing in Organic Chemistry: An Easy Approach to Understanding Reaction Mechanisms, (John Wiley & Sons, 2008).
3. Robert B. Grossman, The Art of Writing Reasonable Organic Reaction Mechanisms, (Springer, 2007).
4. William Ogilvy Kermack and Robert Robinson, J. Chem. Soc., Trans., 1922,121, 427-440.
5. Daniel P. Weeks, Pushing Electrons: A Guide for Students of Organic Chemistry, (Brooks Cole, 1998)
6. Morrison, Robert; Boyd, Robert (1989). Organic Chemistry (5th edition). Prentice Hall of India. ISBN 0-87692-560-3.
7. Lenoir, D.; Chiappe, C. Chem. Eur. J. 2003, 9, 1036.
8. Lapworth, A. Nature 1925, 115, 625.

UNIT 6: STEREOCHEMISTRY-I

CONTENTS:

- 6.1 Introduction
- 6.2 Objectives
- 6.3 Concept of isomerism
- 6.4 Types of isomerism
- 6.5 Optical isomerism
 - 6.5.1 Elements of symmetry
- 6.6 Molecular chirality, enantiomers
 - 6.6.1 Stereogenic centre
- 6.7 Optical activity
 - 6.7.1 Properties of enantiomers
- 6.8 Chiral and achiral molecules with two stereogenic centres
- 6.9 Diastereomers
 - 6.9.1 Properties of Diastereomers
 - 6.9.2 Threo and erythro diastereomers
 - 6.9.3 Meso compound,
 - 6.9.4 Resolution of enantiomers
 - 6.9.5 Inversion, retention and racemization
- 6.10 Relative configuration and absolute
 - 6.10.1 D& L system of nomenclature
 - 6.10.2 R& S system of nomenclature
 - 6.10.3 Sequence Rule
- 6.11 Summary
- 6.12 Terminal Question
- 6.13 Bibliography

6.1 INTRODUCTION

Stereochemistry deals with three dimensional representation of molecule in space. This has sweeping implications in biological systems. For example, most drugs are often composed of a single stereoisomer of a compound. Among stereoisomers one may have positive effects on the body and another stereoisomer may not or could even be toxic. An example of this is the

drug thalidomide which was used during the 1950s to suppress the morning sickness. The drug unfortunately, was prescribed as a mixture of stereoisomers, and while one stereoisomer actively worked on controlling morning sickness, the other stereoisomer caused serious birth defects.

The study of stereochemistry focuses on stereoisomers and spans the entire spectrum of organic, inorganic, biological, physical and especially supramolecular chemistry. Stereochemistry includes method for determining and describing these relationships; the effect on the physical or biological properties.

6.2 OBJECTIVES

After completing this unit learners able to:

- Describe isomers and explain the structural formulae for a variety of isomeric organic compounds
- Explain various kinds of structural and stereo isomerism along with their representation.
- Differentiate geometrical and optical isomers
- Represent three dimensional organic molecules in two dimensions
- Learn chirality, enantiomers, diastereomers and their relative/absolute configurations
- Learn the nomenclature (cis-trans, E/Z, D/L, d/l, erythro/threo and R/S) of different stereoisomers

6.3 CONCEPT OF ISOMERISATION

The word isomerism originated from Greek word *isomer* (*iso*= equal; *mers* = part). When two or more compounds having the same molecular formula but exhibit difference in their chemical and/or physical properties are called isomers and the phenomenon is known as isomerism.

6.4 TYPES OF ISOMERISM

Generally isomerism can be divided into two categories;

- a. Structural (constitutional) Isomerism
- b. Stereo (configurational) Isomerism

a. Structural (constitutional) Isomerism

Structural isomerism is also known as ‘constitutional isomerism’. Structural isomerism arises when a molecule can be represented in two or more than two different structures. The difference in structure is due to the difference in the arrangement of atoms within the molecules, irrespective of their position in space. In other words, structural isomers are compounds that have identical molecular formulae but different structural formulae; and the phenomenon is called structural isomerism.

Examples 1: Structural isomer of Butane (C₄H₁₀) and Bromobutane (C₄H₉Br)

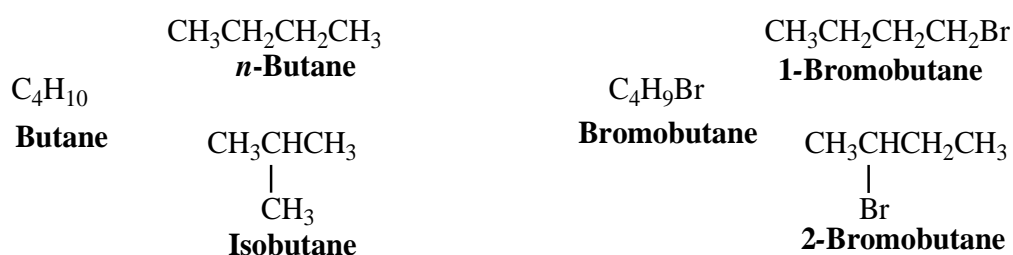

Structural isomerism can also be subdivided into five types

- 1) Chain Isomerism
- 2) Functional Isomerism
- 3) Position Isomerism
- 4) Metamerism
- 5) Tautomerism

1) Chain Isomerism: Chain isomers are those isomers having a difference in the order in which the carbon atoms are bonded to each other. In other words, chain isomers have variable amounts of branching along the hydrocarbon chain.

☞ If you observe two or more than two molecules having the same molecular formulae, but a difference in their hydrocarbon chain length, you should understand that these are chain isomers of each other.

Example 2: Chain isomers of Butane (A) and Pentane (B)

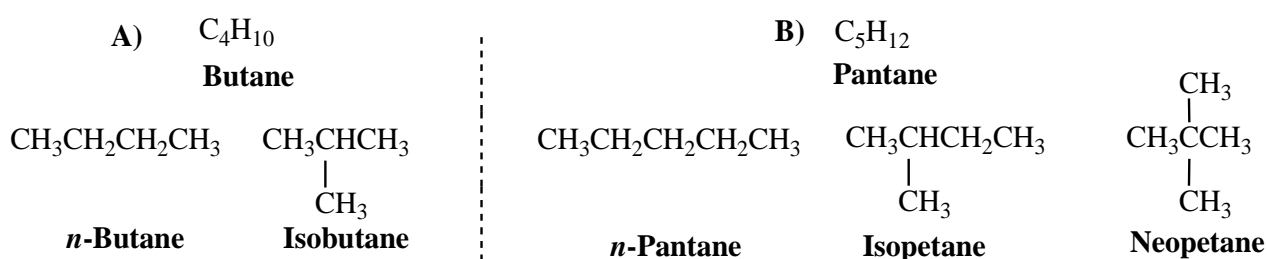

2) **Functional Isomerism:** Two or more than two molecules those having the same molecular formulae but have different functional groups are called functional isomers and the phenomenon is termed as functional isomerism.

☞ *If you observe two or more than two molecules having same molecular formulae, but difference in their functional groups, you should understand that these are functional isomers of each other.*

Example 3: Ethyl alcohol and Dimethyl ether



Example 4: *n*-Butyl alcohol and Diethyl ether



3) **Position Isomerism:** Two or more than two molecules those having same molecular formulae but having difference in the position of functional group on the carbon chain are called position isomers and the phenomenon is called as position isomerism.

☞ *If you observe two or more than two molecules having same molecular formulae, but difference in their functional groups, you should understand that these are functional isomers of each other.*

Example 5: 1-Butene and 2-Butene



Example 6: 1-Butyl alcohol, 2-Butyl alcohol and *t*-Butyl alcohol

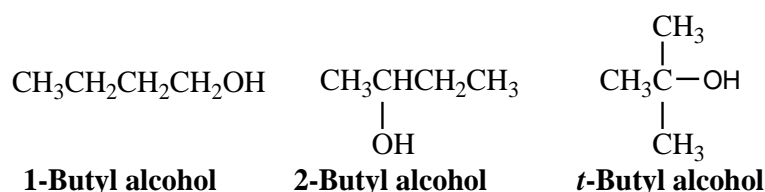

4) **Metamerism:** Two or more than two molecules those having same molecular formulae and functional group but having difference in the distribution of carbon atoms on either side of functional group are called metamers and the phenomenon is called the metamerism.

☞ When you see two or more than two molecule with identical molecular formulae but while structural representation you observe there is a difference in the alkyl group attached to same functional group you should understand these molecules are metamers of each other.

Example 7: Diethyl ether, Methyl propyl ether and isopropyl methyl ether

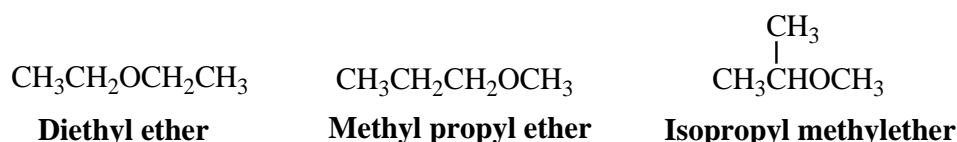

Example 8: Diethyl amine, Methyl propyl amine and isopropyl methyl amine

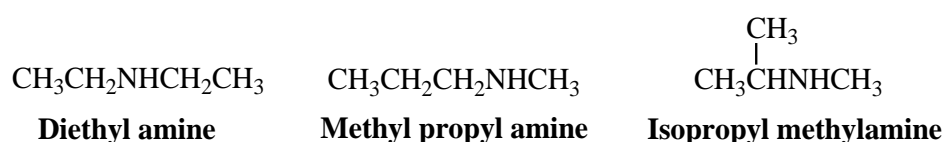

5) **Tautomerism:** This is a special kind of isomerism where both the isomers are interconvertible and always exist in a dynamic equilibrium to each other. Due to their interconversion change in functional group takes place that gives two different isomers of an organic compound. This phenomenon is called Tautomerism.

☞ When you observe two different isomeric forms of an organic compound are rapidly interconvertible to each other you should recognize them as tautomer of each other.

i. **Remember:** Tautomers are not the resonance structure of same compound

Example 9: Acetone exists in rapid equilibrium with Prop-1-en-2-ol

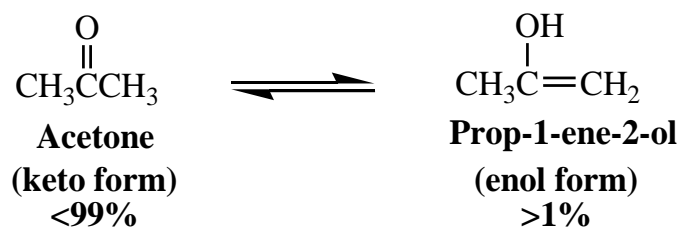

Example 10: Tautomeric forms of Ethyl acetoacetate under rapid equilibrium

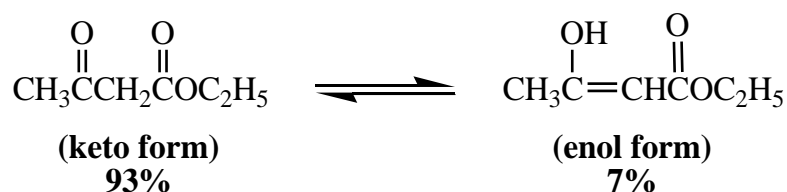

b. Stereo (configurational) Isomerism

Stereoisomerism arises due to the difference in arrangement (configuration) of atoms or groups in space. When two or more than two isomers have the same structural formulae but having difference in the arrangement (configuration) of atoms in space are called stereo isomer and the phenomenon is called stereo isomerism.

Stereo isomerism can be further classified as

- i. Geometrical or cis-trans isomerism
- ii. Optical isomerism

Geometrical isomerism is generally observed in alkenes and cyclic compounds due to their restricted rotation around carbon-carbon bond. For example *cis*- and *trans* 2-butene have same connection of bond and molecular formulae.

☞ If you observe two similar groups are on the same side of C=C bond this is called *cis*-isomer; whereas, if two similar groups are on opposite side of C=C bond this is known as *trans*-isomer.

Example 11: *cis*- and *trans*- isomerism in 2-butene

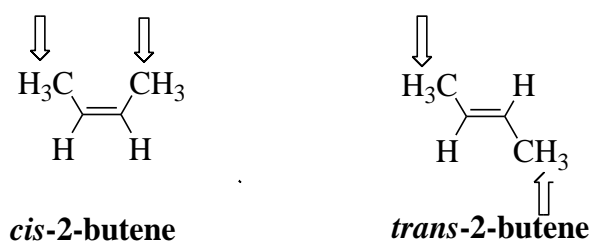

☞ You can understand that due to the presence of one σ (sigma) and one π (pi) bond in carbon-carbon double bond, rotation around C=C bond is not possible. The restricted rotation around C=C bond is responsible for geometrical isomerism in alkenes.

You can easily observe that rotation around C-C bond is also not possible in cyclic compounds as the rotation would break the bonds and break the ring. Thus geometrical isomerism is also possible in cyclic compounds.

Example 12: *cis*- and *trans*- isomers of 1,2-dimethylcyclopropane

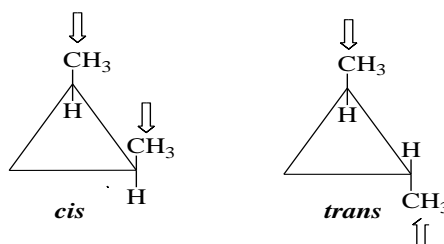

6.5 OPTICAL ISOMERISM

Optical isomerism is another class of *stereoisomerism*. The organic compounds that exhibit optical isomerism must have a unique ability to rotate the plane polarized light either towards left or towards right hand directions. This unique ability is generally known as optical activity. Optical activity of any compound is measured by analyzing the sample in an instrument called **Polarimeter**. A solution of known concentration of optically active compound is when exposed to the beam of plane polarized light, the beam of plane polarized light is rotated through a certain number of degrees, either to the clockwise (right) direction or anti-clockwise (left) direction. The compound which rotates the plane polarized light towards clockwise direction is called to be **dextrorotatory** (represented by +); whereas, the compound which rotates the plane polarized light towards anti-clockwise direction is called to be **levorotatory** (represented by -). Figure 6.1 shows the schematic representation of polarimeter.

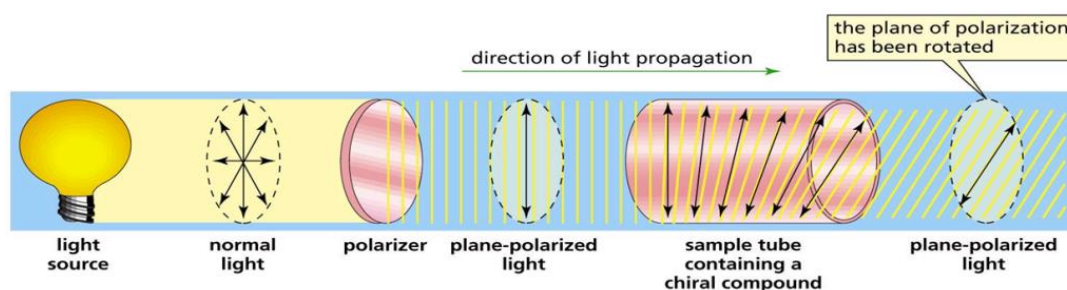

Figure 6.1. Schematic representation of simple polarimeter

- ☞ *The degree of rotation depends upon the number of the molecules of the compounds falls in the path of beam. To compare the rotating power of different optically active compounds, the specific rotation of each compound is calculated and then comparison should be made.*
- ☞ *Specific rotation is defined as the degree of rotation offered for the given wavelength of plane polarized light at given temperature by a solution of 1g/mL concentration is filled in a 10 cm length sample cell. Specific rotation is represented by $[\alpha]_{\lambda}^t$ and can be calculated as*

$$[\alpha]_{\lambda}^t = \frac{100\alpha}{lc}$$

Where α is observed angle of rotation; t is the temperature of during experiment; λ is the wavelength of light used; l is the length of the tube in decimeter; and c is the concentration of the compounds per 100 mL of solution.

ii. Remember:

Optically active compounds always exist in two isomeric forms which rotates the plane polarized light by equal degrees in opposite directions. The optical isomer which rotates the plane polarized light towards right (clockwise direction) is known as Dextrorotatory Isomer or (+)-isomer, whereas, the optical isomer which rotates the plane polarized light towards left (anticlockwise direction) is known as Levorotatory Isomer or (-)-isomer.

6.5.1 Elements of symmetry:

All optically active molecules/object are chiral and they exhibit enantiomerism (Figure 6.2). A chiral molecule is that which cannot be superimposed on its mirror image; however, both the non-superimposable isomers are called enantiomers. We will learn more about chirality and enantiomerism in separate section of this unit.

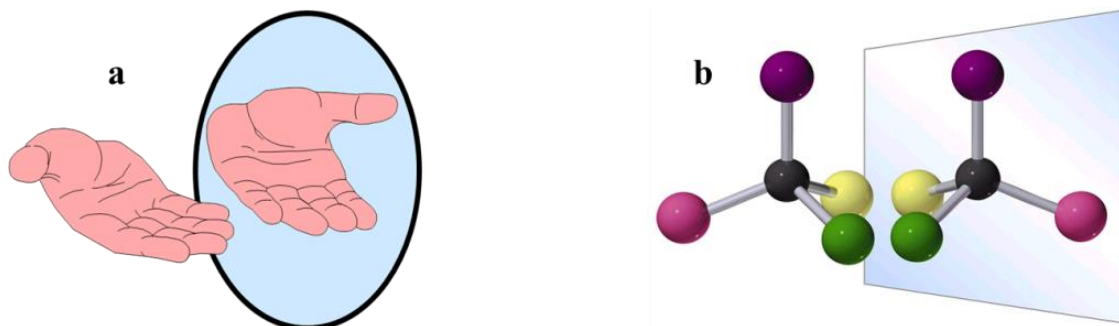

Figure 6.2. (a) Non superimposable mirror image relationship of right and left hands. (b) Ball and stick model of tetraivalent chiral carbon atom.

Elements of symmetry are a simple tool to identify whether a molecule is chiral or not. The necessary condition for optically active molecule to be chiral is that, the molecule should not possess any kind of symmetry elements. The elements of symmetry are generally categorized as follows:

- (i) Simple axis of symmetry (C_n)
- (ii) Plane of symmetry (σ)
- (iii) Centre of symmetry (C_i)
- (iv) Alternating axis of symmetry (S_n)

(i) Simple axis of symmetry (C_n):

When a rotation of $360^\circ/n$ (where n is any integer like 1,2,3...etc.) around the axis of a molecule or object is applied, and the rotated form thus obtained is non-differentiable from the original, then the molecule/object is known to have a *simple axis of symmetry*. It is represented by C_n .

Example 13: Water molecule has C_2 (two fold axis of symmetry) whereas chloroform has C_3 axis of symmetry.

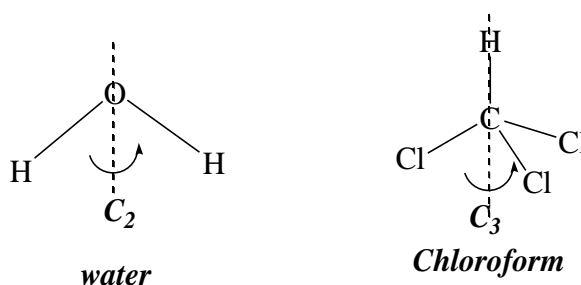

☞ From above example you can easily understand that if you rotate the water molecule by 180° (i.e. $360^\circ/2=180^\circ$) along its molecular axis you will get the identical (non-differentiable) form of water molecule, hence water molecule has two fold of symmetry. Similarly, if you rotate the chloroform molecule by 120° (i.e. $360^\circ/3=120^\circ$) along its molecular axis you will get the identical (non-differentiable) form of chloroform molecule, hence chloroform molecule has three fold of symmetry.

(ii) Plane of symmetry (σ):

It is defined as 'when a plane that divides a molecule or object in to two equal halves which are related to object and mirror image is known as *plane of symmetry*. It is represented by σ .

Example 14: Plane of symmetry in Tartaric acid

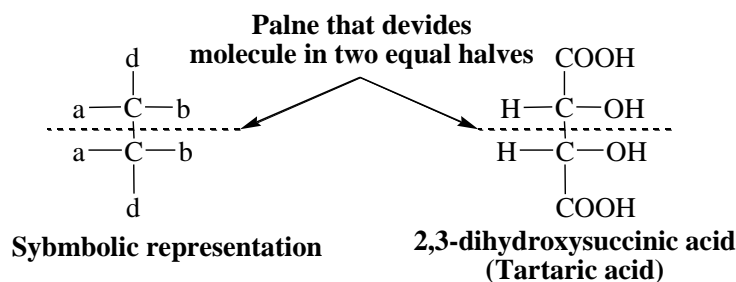

☞ From above example you can easily understand that if we put a mirror plane/reflection plane exactly at the centre axis of the molecule/object; you will found that the mirror

image thus obtained is the complementary of the original and both will give us the appearance of complete molecule/object.

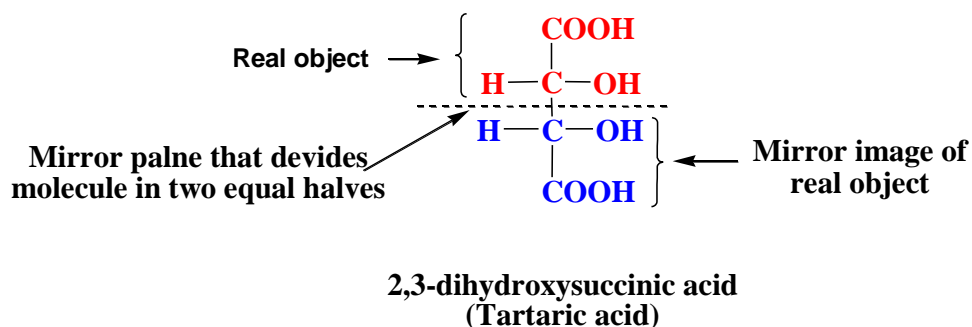

(iii) **Centre of symmetry (C_i):** A molecule has a centre of symmetry when, for any atom in the molecule, an identical atom exists diametrically (diagonally) opposite to this centre and at equal distance from it.

Example 15: An isomer of 1,3-dichloro-2,4-dibromocyclobutane has a centre of symmetry

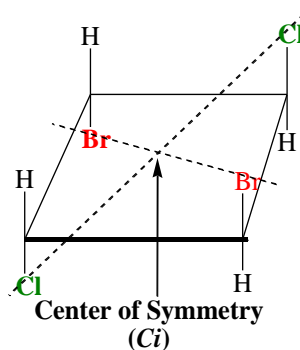

☞ From above example you may understand that all the identical atoms are situated diagonally and at equal distance from the centre. This is called centre of symmetry.

(iv) **Alternating axis of symmetry (S_n):** An alternate axis of symmetry is defined as, when a molecule is rotated by $360^\circ/n$ degrees about its axis and then a reflection plane is placed exactly at perpendicular to the axis, and the reflection of the molecule thus obtained is identical to the original. It is represented by S_n .

Example 16. An isomer of 1,3-dichloro-2,4-dibromocyclobutane has a 2 fold alternate axis of symmetry

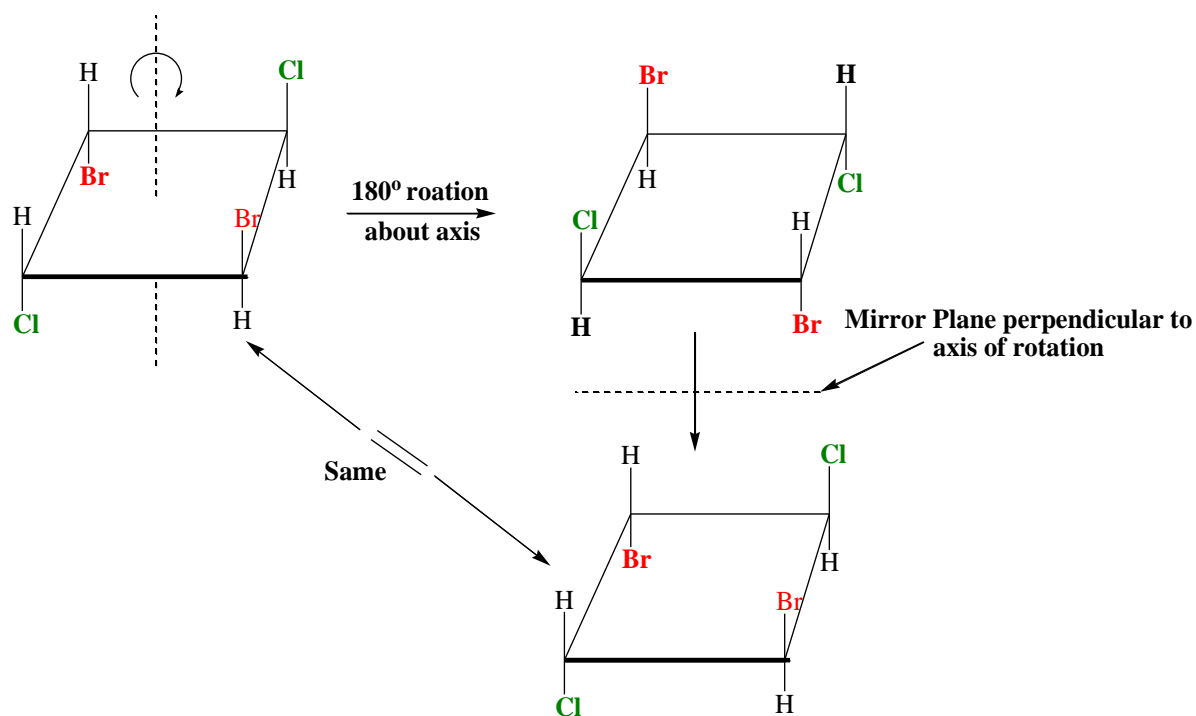

6.6 MOLECULAR CHIRALITY, ENANTIOMERS

The necessary condition for a molecule to have optical isomerism is that molecule should not have any kind of symmetry elements present in it, in other words the molecule should be dissymmetric. Such molecules are called 'Chiral' and the property is called 'molecular chirality'. Optically active chiral molecules which are non-superimposable on their mirror images are called 'enantiomers' and the phenomenon is known as 'enantiomerism'. To exhibit optical isomerism an organic compound must have at least one asymmetric carbon atom. An asymmetric carbon atom is that which is bonded to four different atoms or groups.

☞ We can easily understand the chirality by comparing our hands (left hand and right hand). Our left hand and right hand are the best example of non-superimposable mirror image of each other. Each hand is therefore considered as chiral.

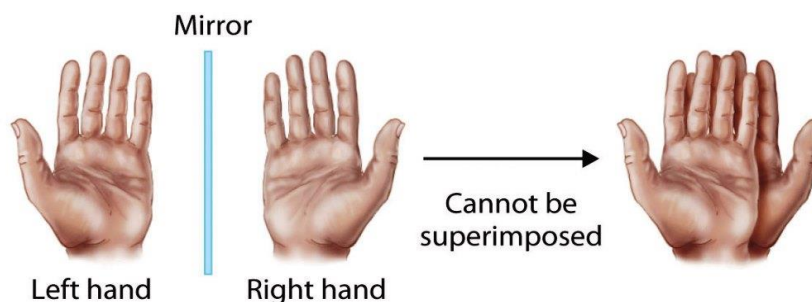

Remember: Our left hand and right hand are non-superimposable mirror image of each other each one of them is chiral. Chirality is the necessary and sufficient condition for the existence of enantiomers.

Example 17. Tartaric acid has two asymmetric carbon and it exists in four forms, out of them two form are optically active and two are optically inactive.

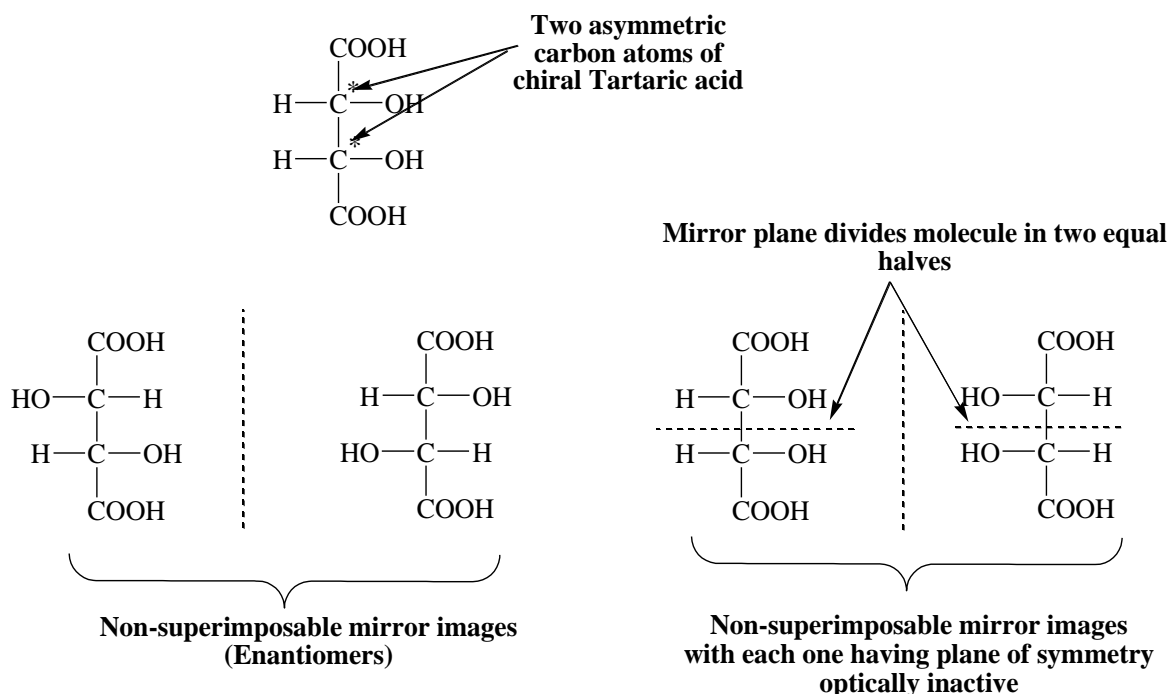

6.6.1 Stereogenic Centre:

As we discussed in previous section that if a molecule contains one carbon atom which is directly bonded with four different groups or atoms, and the molecule do not have any kind of symmetry element present in it, such molecule is called asymmetric or chiral.

When the interchange of the position of two directly bonded groups or atoms of a centre carbon atom results a new stereoisomer, such chiral centre is called stereo centre or stereogenic centre.

If the new stereoisomer is a non-superimposable mirror image of the original molecule such carbon centre is called chiral carbon centre.

Remember: All the chiral centres are stereogenic centres but all stereogenic centres are not chiral centre.

Example 18: Bromochlorofluoriodomethane exhibits chiral carbon centre



Interchange of F and Cl results non-superimposable stereoisomers

6.7 OPTICAL ACTIVITY

It is already known to you (from section 4.5) that the optical activity is an ability of a chiral molecule to rotate the plane of plane-polarized light either towards left or right direction. The rotation is measured by an instrument called Polarimeter. When a beam of plane polarized light passes through a sample that can rotate the plane polarized light, the light appears to dim because it no longer passes straight through the polarizing filters. The amount of rotation is quantified as the number of degrees that the analyzing lens must be rotated to observe the no dimming of light appears. Optical rotation can be measured by using the following formulae

$$[\alpha]_{\lambda}^t = \frac{100\alpha}{lc}$$

Where α is observed angle of rotation; t is the temperature of during experiment; λ is the wavelength of light used; l is the length of the tube in decimeter; and c is the concentration of the compounds per 100 mL of solution.

Optically active chiral compounds that are non-superimposable mirror image of each other are called enantiomers.

6.7.1 Properties of enantiomers:

The main properties of enantiomers are given as follow

- Enantiomers always exist in pair
- Enantiomers are non-superimposable mirror image to each other
- Enantiomers have same physical properties (like boiling point, melting point, solubility, density, viscosity, refractive index etc.) and chemical properties in achiral environment

- Each enantiomer have opposite behavior with respect to plane polarized light, if one of them will rotate the plane polarized light towards right hand direction then definitely the other will rotate the plane polarized light towards left hand direction.
- Each enantiomer shows the same chemical reactivity with achiral reagent; however they have different reactivity with chiral reagent.

Example 19: Glyceraldehyde molecule is a chiral molecule. It has a pair of enantiomer with same physical properties except their behavior towards plane polarized light

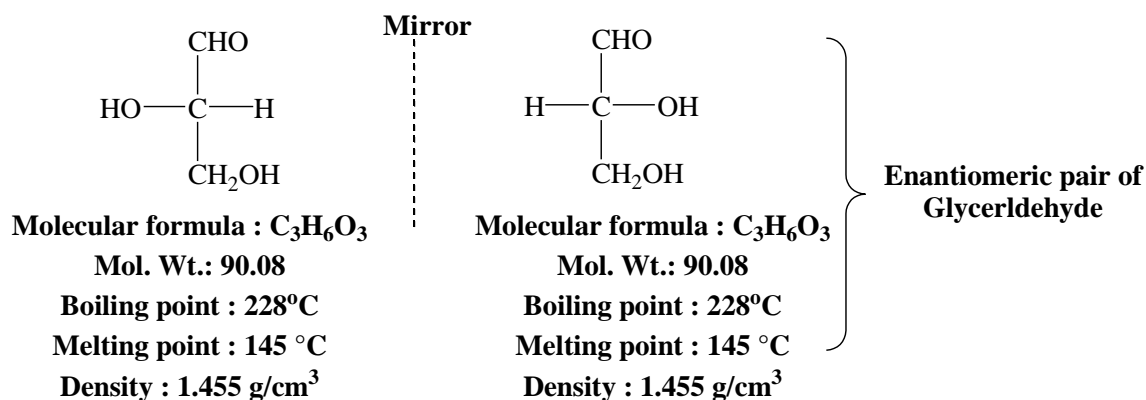

☞ You can see that the glyceraldehyde molecule can exist in two enantiomeric forms which differ only in the arrangement of bonded atoms around the central chiral carbon. The physical properties (like molecular formula, molecular weight, melting point, boiling point and density etc.) of both the isomers are the same. But if one isomer will rotate the plane polarized light towards right hand direction (dextrorotatory) then the other one will rotate the plane polarized light towards left hand direction (levorotatory).

6.8 CHIRAL AND ACHIRAL MOLECULES WITH TWO STEREOGENIC CENTRES

As we have discussed earlier that chiral molecules are those in which the central carbon atom is bonded directly through four different atoms/groups and do not have any kind of symmetry element present in it and the molecule has a non-superimposable mirror image. However, those molecules in which the central carbon atom is directly bonded through four different atoms or groups and it satisfies any kind of symmetry elements are called achiral molecules. Achiral molecules have superimposable mirror images.

Let us consider the stereoisomers of Tartaric acid which has two stereocentres with identical atoms/groups attached to both the stereocentres. Tartaric acid has two stereo

centres and can have four stereoisomers out of which two stereoisomers are non-superimposable mirror image of each other called enantiomers and chiral; and rest two are identical to each other and also have plane of symmetry hence it can be divided into two equal halves, therefore are achiral.

Example 20: Tartaric acid has two stereo centres with three stereoisomers (two are chiral and one achiral stereoisomer)

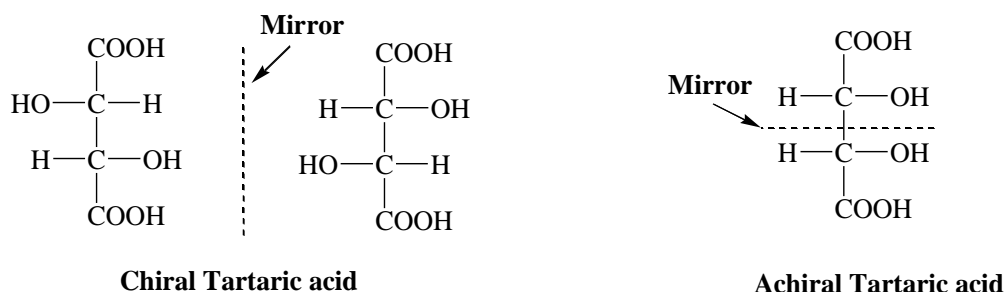

6.9 DIASTEREOMERS

Diastereomers are those stereoisomers that are not mirror image of each other, in other words you can understand the diastereomers are stereoisomers that are not enantiomers. Diastereomers are non-enantiomeric stereoisomers with two or more stereo centres. The pair of stereoisomer that differs in the arrangement of atoms/groups bonded with at least one stereocentres is called diastereomers.

Example 21: D-Galactose, D-Glucose and D-Mannose are the non-mirror image stereoisomer of each other. Therefore are called diastereomers.

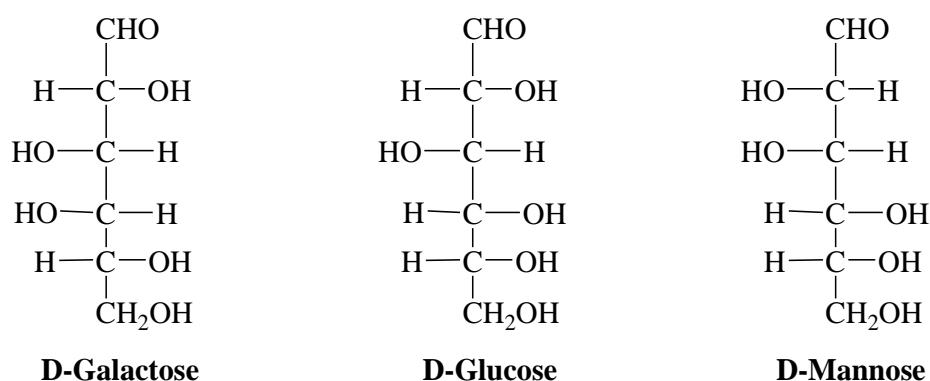

Example 22: *cis*- and *trans*-2-butenes are non-mirror image stereoisomers of each other hence are called diastereomers.

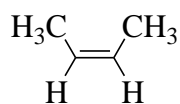
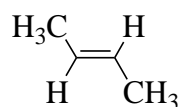
*cis*-2-butene*trans*-2-butene

6.9.1 Properties of Diastereomers

The main properties of diastereomers are given as follows:

- All the stereoisomers except enantiomers are diastereomers.
- Diastereomers have different physical properties like boiling point, melting point, density, solubility, density, viscosity, refractive index etc.
- Diastereomers have different chemical properties like rates of reactions, reactivity even in achiral reaction medium.
- This difference in physical and chemical properties of diastereomers is very useful in the separation of enantiomers from their mixture.

6.9.2 Threo and erythro diastereomer

Threo and *erythro* nomenclature method is designated by organic chemists to assign appropriate name to diastereomers. The *threo* and *erythro* naming is given only to those diastereomers having two adjacent stereocentres. The nomenclature is applicable to these diastereomers if there are two common atoms/groups bonded to each adjacent stereocentre. In other words the terms *erythro* and *threo* are generally applied only to those molecules which do not have symmetric ends. However, when the ends are symmetric then instead of *erythro* and *threo* the *meso* and *dl* nomenclature is preferred. We will discuss separately about *meso* and *dl* in this unit.

If the similar groups/atoms on adjacent stereocentres of diastereomer are on same (*syn*) side it is designated as *erythro*, whereas if the similar groups/atoms on adjacent stereocentres of diastereomer are on opposite (*anti*) side the diastereomer is designated as *threo*.

Example 23: You can easily understand the erythro and threo nomenclature by taking examples of 3-bromo-2-butanol and 2,3-dibromo pentane.

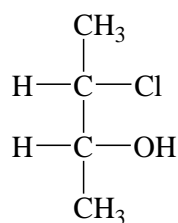
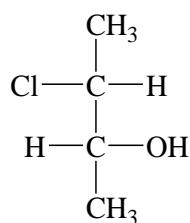
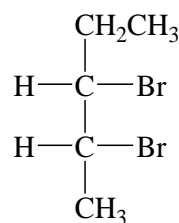
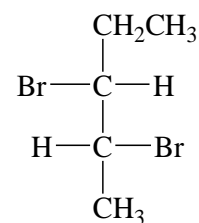
*Erythro**Threo***3-Chloro-2-butanol***Erythro**Threo***2,3-Dibromopentane**

☞ You can see if both the hydrogen atom on two adjacent stereocentres of 3-chloro-2butanol lies on same (syn) side the isomer is called erythro, whereas, when both the hydrogen atoms on two adjacent stereocentres of 3-chloro-2butanol lies on opposite (anti) side the isomer is called threo. Similarly you can find the same observation with 2,3-dibromopentane and designate the isomers as erythro and threo.

☞ You must also remember that the each erythro and threo stereo isomer can have their non-superimposable mirror image (enantiomer). Thus there will be always one enantiomeric pair of erythro and one enantiomeric pair of threo stereoisomer exists for a stereoisomer with two similar atoms on adjacent stereocentres.

6.9.3 meso- Compounds

A compound with two or more carbon stereocentre but also having a plane of symmetry is called *meso* compounds. All the carbon centres have four different atoms/groups but the compound can be divided in to two equal halves which are superimposable mirror image.

Example 24: 2,3-dibromobutane have two stereocentres, but the molecule have two symmetric ends therefore it can be divided in to two equal halves. In other words the molecule have plane of symmetry.

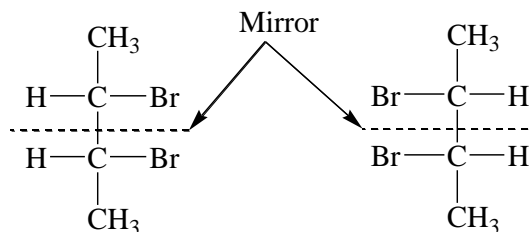
**2,3-Dibromobutane**

☞ We can see that even the 2,3-dibromobutane have non superimposable mirror image but this molecule have an internal plane of symmetry hence this molecule is optically inactive or achiral. This molecule will not be able to rotate the plane polarized light in any

direction. If one half of the molecule will rotate the plane polarized light towards right hand direction with some degrees; the other half will rotate the plane polarized light towards left hand direction with same degrees of rotation. Thus the net rotation of the plane polarized light is zero. Such molecules are called meso compounds.

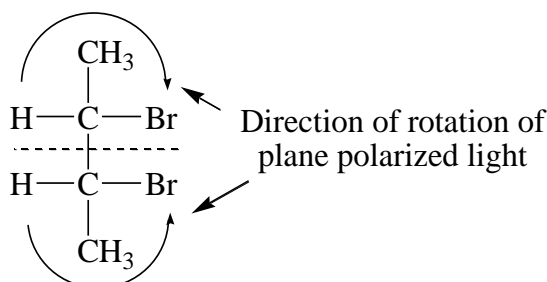

Example 25: Another example of meso compound is one of the stereo isomeric forms of Tartaric acid (2,3-dihydroxysuccinic acid). The molecule is optically inactive because it has internal plane of symmetry.

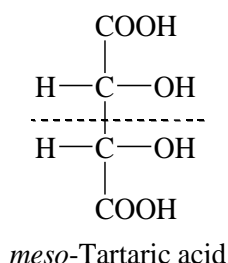

6.9.4 Resolution of enantiomers

Before we discuss about resolution of enantiomers, you must have an understanding of *racemic mixture* or *racemates*. A racemates is an equimolar mixture of a pair of enantiomers. The racemic mixture or racemates are optically inactive due to mutual or external compensation of two enantiomeric constituents. Racemic mixture in liquid and vapor phase shows physical properties (like boiling points, density, refractive index etc.) identical to those of pure enantiomers. However, the solid phase enantiomeric mixtures have some properties different from the pure enantiomers.

Remember: *Racemic mixture is not a meso compound; since both are optically inactive. The racemic mixture is an equimolar mixture of two enantiomers whereas meso is a single compound. Meso compounds are optically inactive because of the internal compensation; however, the racemic mixtures (racemates) are optically inactive because of the external compensation.*

You might have aware with that the enantiomerically pure compounds are of great importance in chemical and pharmaceutical areas. But during the synthesis of optically active compounds using achiral reaction condition and achiral reagents, it always gives racemic mixture (racemate).

Example 26: The addition of HBr on *beta*-Methyl styrene gives an equimolar mixture of enantiomers.

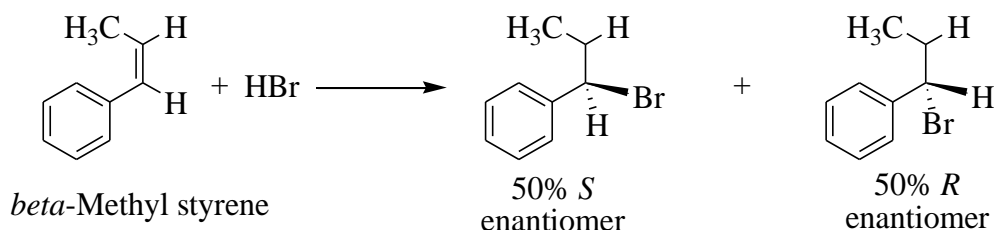

Therefore to obtain the pure enantiomers we must have to separate the racemic mixture in to corresponding pure enantiomers. Thus, the separation process of a racemic mixture in to its pure individual enantiomeric constituents is called resolution of racemic mixtures (resolution of enantiomers). Since enantiomers have identical physical properties (like solubility, boiling point, melting point, density, refractive index etc.), therefore, they cannot be separated by common physical techniques such as direct crystallization, distillation or basic chromatography. There are four general methods that are extensively being used for the resolution of racemic mixtures.

- i. Mechanical separation (crystallization method) method
- ii. Diastereomer formation method
- iii. Chromatographic method
- iv. Biochemical/enzymatic methods

i. Mechanical separation (crystallization method) method: Separation of enantiomers from a racemic mixture can be achieved by direct crystallization of optically active components. The crystallization method was invented by Louis Pasteur (1848); during his pioneering work he was able to isolate the stereoisomers of tartaric acid from its racemic mixture. The stereoisomers of Tartaric acid were crystallized separately from solution and separated; since the crystals were having different symmetry and shape. This type of separation is very rare.

Example 27: Resolution of Tartaric acid was achieved by Louis Pasteur by crystallizing them as R/S form of sodium ammonium tartrate.

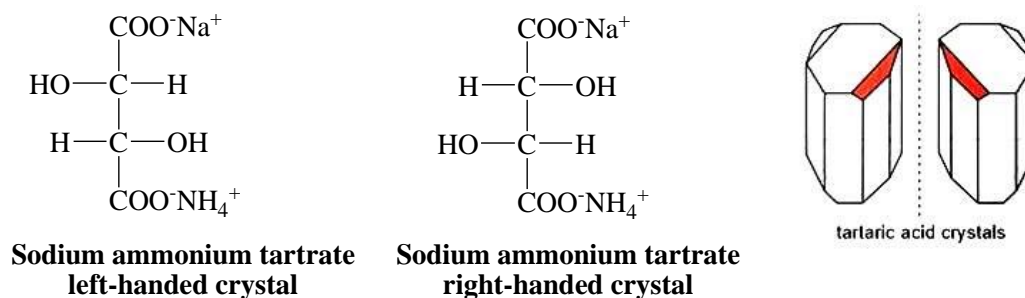

ii. Diastereomer formation method: This is one of the best methods for separation of enantiomers and was also invented by Louis Pasteur (1858). In this method a racemic mixture is converted into a mixture of diastereomers of the enantiomeric constituents of that mixture by using a pure enantiomer of another compound.

We have already discussed in the previous section of this unit that the diastereomers have different physical (like solubility, boiling point, melting point, density, refractive index etc.) and chemical properties (like chemical rate and reactivity etc.). Therefore these diastereomers can be easily separated by either fractional crystallization or fractional distillation. After separation of diastereomers each of them is converted back into the individual enantiomers of racemate by suitable reactions.

Example 28a: R and S form of 2-hydroxypropanoic acid in an equimolar mixture can be converted in to a mixture of diastereomers by reacting it with S-Brucine.

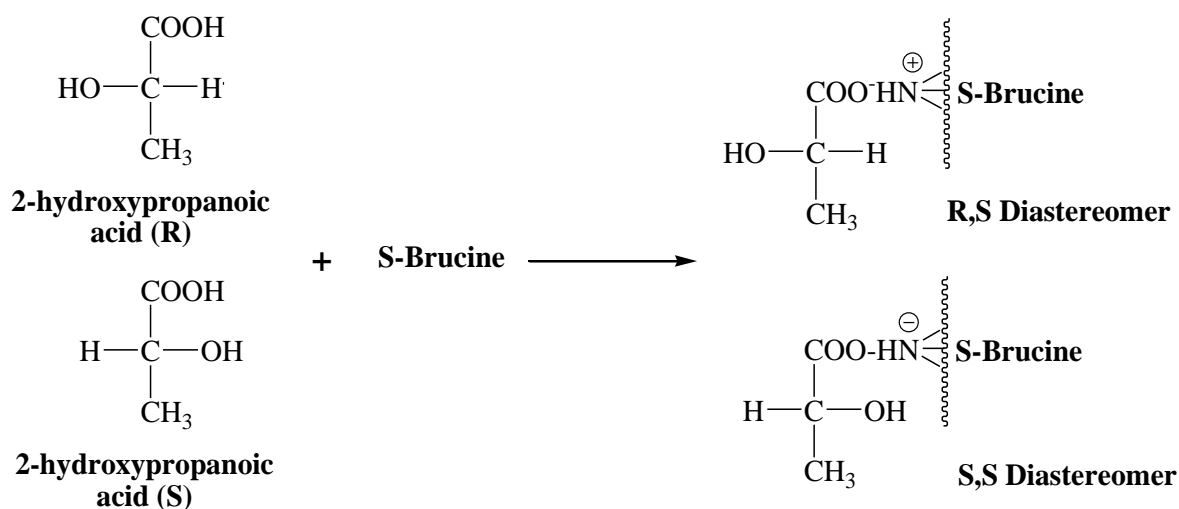

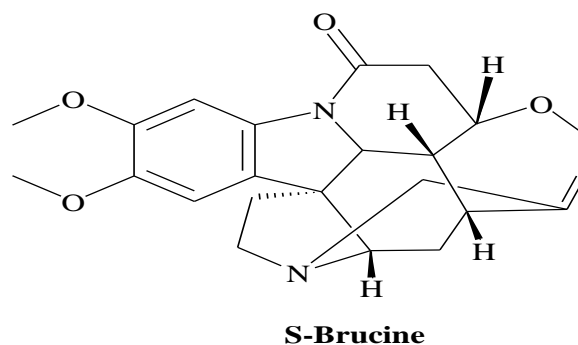
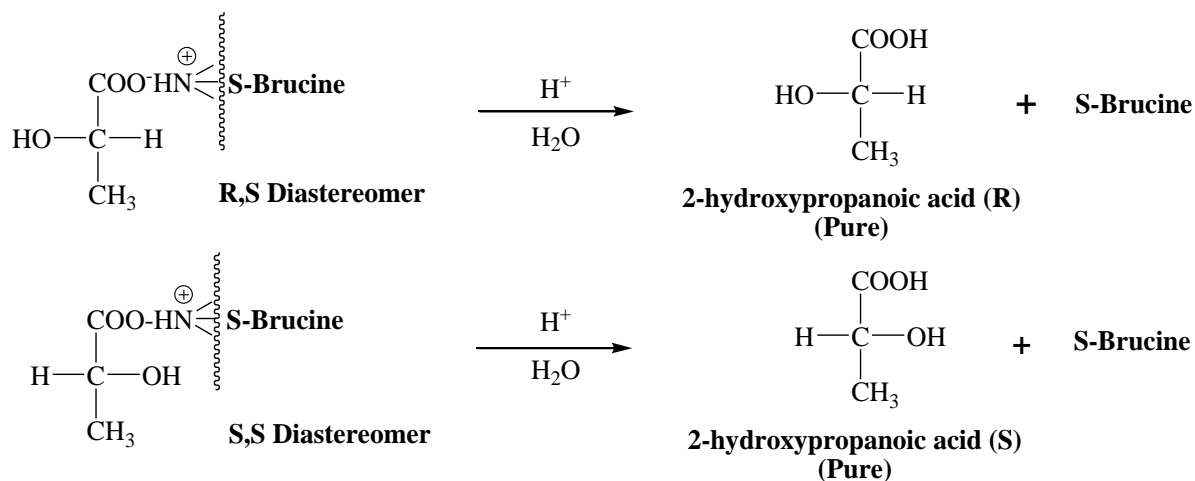

Figure 6.3: S-Brucine (an optically active isomer)

We can see from above example that the enantiomeric mixture of 2-hydroxypropanoic acid can be easily converted in to corresponding diastereomeric salts by reacting with a optically pure base called S-Brucine. Both the diastereomeric salts can be separated by fractional crystallization. The separated diastereomers can be converted in to respective pure enantiomers of 2-hydroxypropanoic acid by simple acidic hydrolysis.

Example 28b: The acidic hydrolysis of diastereomeric salt of 2-hydroxypropanoic acid gives pure form (R/S) of 2-hydroxypropanoic acid.



iii. Chromatographic method: Racemic mixture can also be separated by column chromatography by adsorbing the racemates on an optically active solid adsorbent or solid support. The separation of enantiomers is based on the difference in their affinity towards the adsorbent or support. Enantiomer while adsorbing on optically active solid support forms diastereomers those having different stabilities in the eluent (solvent). The enantiomer which has more affinity towards the solid adsorbent will be held more tightly than the other one which has less affinity towards solid adsorbent. Thus the diastereomeric adsorbates when filled in a column and eluted with suitable solvent system the less tightly bonded enantiomer

will be eluted more rapidly and will pass through the column. However, the enantiomer which is tightly bonded with the solid support will be eluted more slowly and will come out later from the column. Hence both the enantiomers will get separated. The schematic representation of chromatographic separation of enantiomers is shown in figure 4.

Example 29: Separation of 2-aminobutane by chromatographic separation method using chiral adsorbent (enantiomer of mandelic acid is attached to a silica stationary phase)

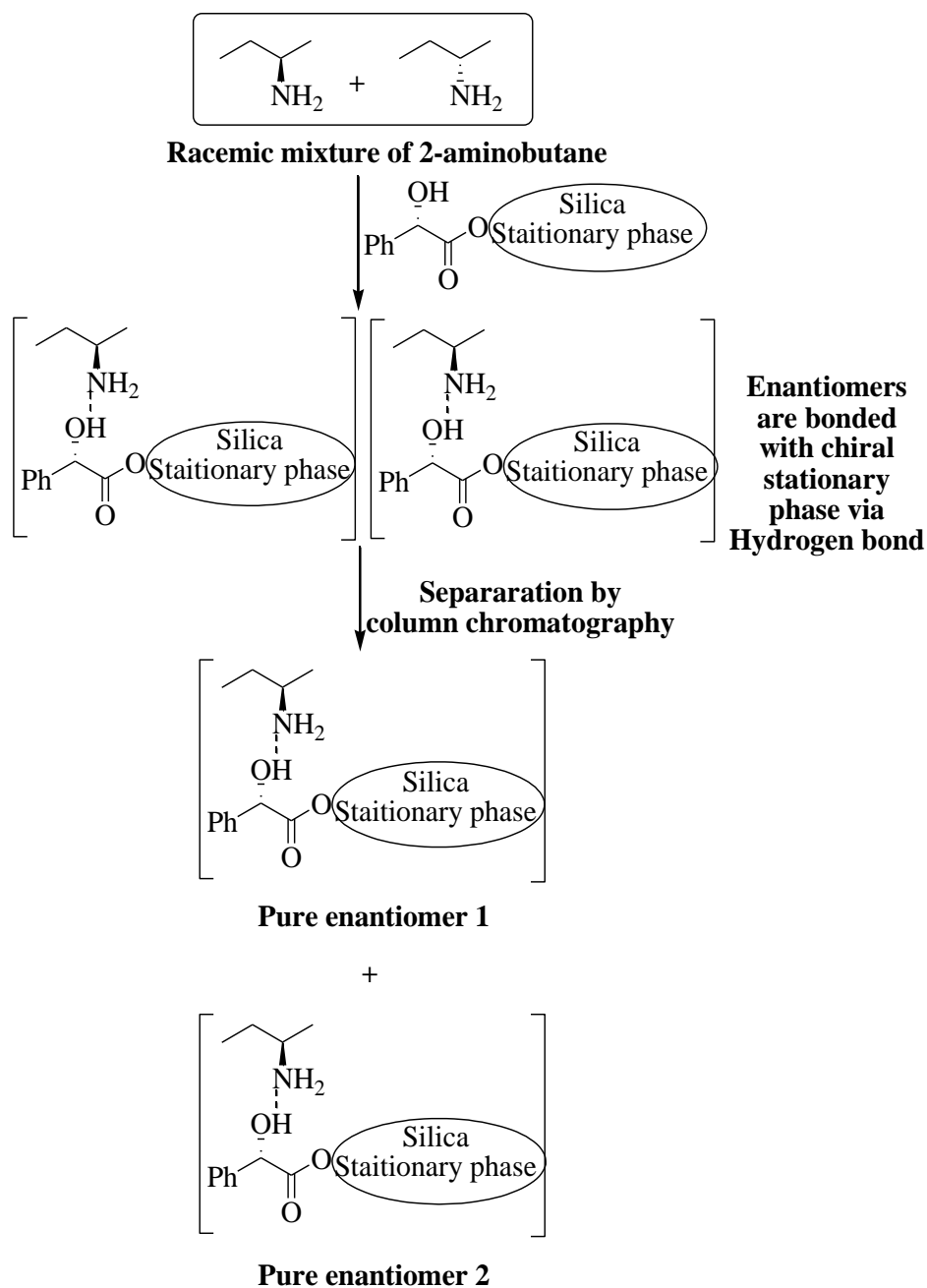

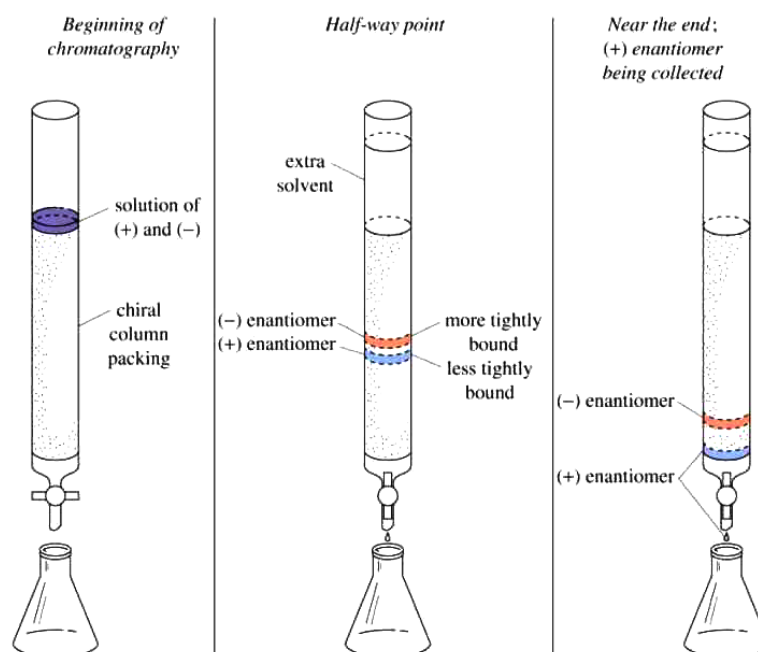
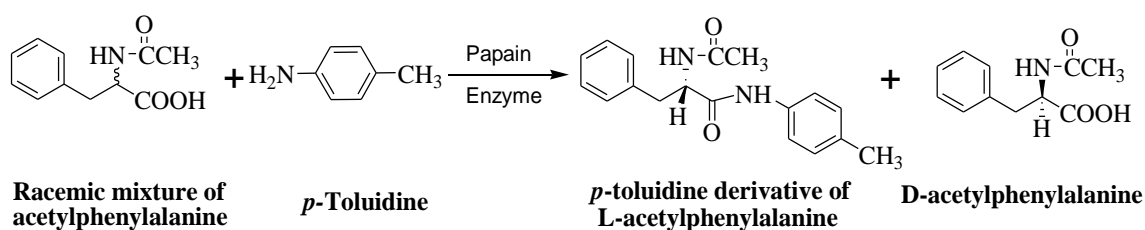

Figure 6.4: Schematic diagram of chromatographic separation of racemic mixture

iv. Biochemical/enzymatic method: Enzymes are also being used for the separation of enantiomers from racemic mixture. When certain bacteria and moulds are allowed to grow in the solution of racemic mixture, they react with one enantiomer exclusively and form a derivative; as a result only one enantiomer remains in excess in the solution which can be easily separated.

Example 30: Separation of a racemic mixture of acetyl phenylalanine by reacting it with *p*-toluidine catalyzed by an enzyme called papain gives the *p*-toluidine derivative of acetyl-L-phenylalanine and leaves unchanged acetyl-D-phenylalanine.



6.9.5 Inversion, retention and racemization:

In a substitution reaction when a group/atom attached to a chiral carbon atom is replaced by any other atom as a result the configuration (*i.e.* spatial arrangement of atoms around the central atom) of central atom changes, the process is called *inversion of configuration* or simply *inversion*. The product after inversion thus obtained is the non-super imposable mirror

image (enantiomer) of the original molecule. This phenomenon was first observed by the scientist P. Walden therefore it is also known as *Walden Inversion*.

Example 31: Replacement of chlorine atom of Chlorosuccinic acid by hydroxyl ion gives Malic acid with inverted configuration

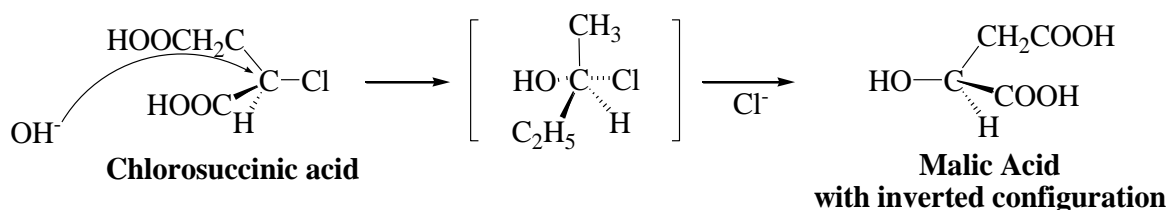

The inversion of configuration depends upon the nature of reagent, the nature of solvent, reaction temperature, the nature of substituents which is replacing the group/atom in the given molecule.

Sometimes you will observe that the replacement of any group/atom in a chiral molecule gives a new optically active isomer without the inversion of configuration. This is known as *retention* of configuration. In other words we can explain the retention of configuration is “the preservation of the spatial arrangements (configuration) of atoms attached with a chiral centre of an optically active molecule during the chemical transformation or reaction”. The retention of configuration is occurs when in a substitution reaction the incoming group/atom approaches to the central chiral atom from the same plane/direction of the leaving group/atom the resultant product thus obtained will have the same configuration as the reactant molecule.

Example 32: (*S*)-1-(1-bromopropyl)benzene on reaction with H₂O gives the mixture of (*S*)-1-phenylpropan-1-ol and (*R*)-1-phenylpropan-1-ol.

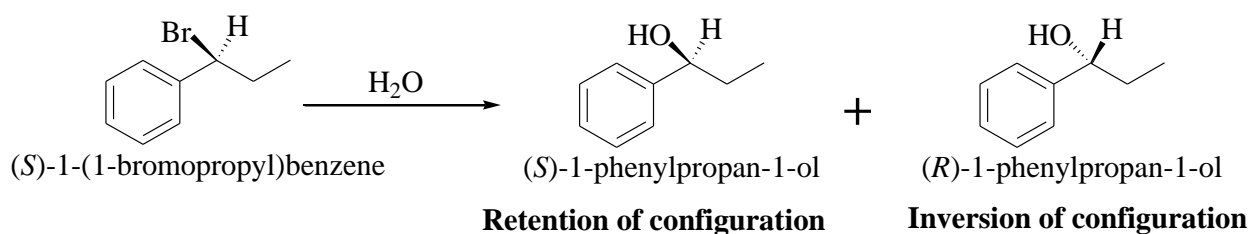

We have already discussed that the equimolar mixture of enantiomer is known as racemic mixture. The process of conversion of an optically active compound in to the racemic mixture/racemate is called *racemization*. The racemization process may take place under the influence of temperature, light or chemical reagents.

Example 33: Racemization of (*S*)-2-iodohexane during reaction with CH₃OH (methanol)

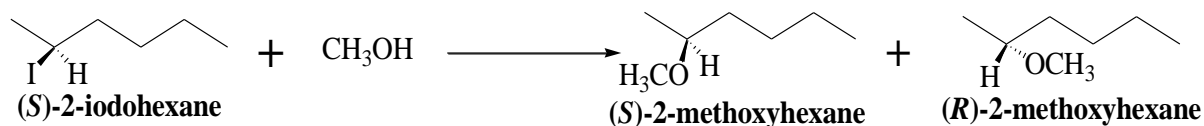

6.10 RELATIVE AND ABSOLUTE CONFIGURATION

Relative and absolute configuration of a compound discusses about the spatial arrangement of atoms/groups around the centre chiral atom. Relative configuration is a comparison of the spatial arrangement of attached atoms/groups of two different chiral centres. Relative configuration is a geometrical property which do not changes on reflection; whereas, the absolute configuration is the precise arrangement of atoms in three dimensional space. The *D/L* system is usually known as relative configuration whereas, the *R/S* stereo descriptor or nomenclature system for chiral molecules is known as absolute configuration. The absolute configuration is a topographic property which changes on reflection.

6.10.1 *D/L* nomenclature:

The *D/L* nomenclature is the oldest nomenclature system for enantiomers. In this nomenclature system the configuration of all the compounds were given with respect to glyceraldehyde molecule, where the configuration of glyceraldehyde molecule is taken as an arbitrary standard. According to this nomenclature if in glyceraldehyde molecule the –OH group on right and –H on left, the –CHO and –CH₂OH groups being on top and bottom, respectively the molecule is designated as (+) Glyceraldehyde and it was arbitrary given the configuration symbol *D*. The mirror image of this compound (–) glyceraldehyde was given the configuration *L*.

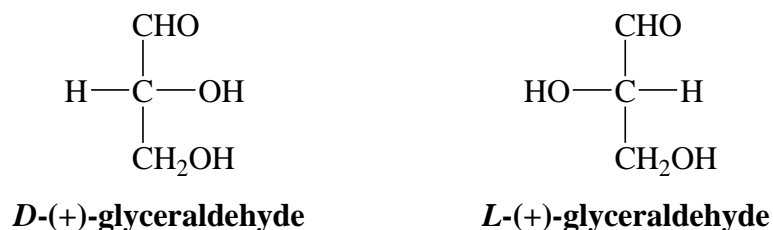

Any compound that can be prepared, or converted in to *D*-(+)-glyceraldehyde will belong to *D* series (relative configuration), whereas, any compound that can be prepared, or converted in to *L*-(+)-glyceraldehyde will belong to *L* series.

Example 34: Lactic acid obtained from *D*-(+)-glyceraldehyde and hence assigned *D* configuration

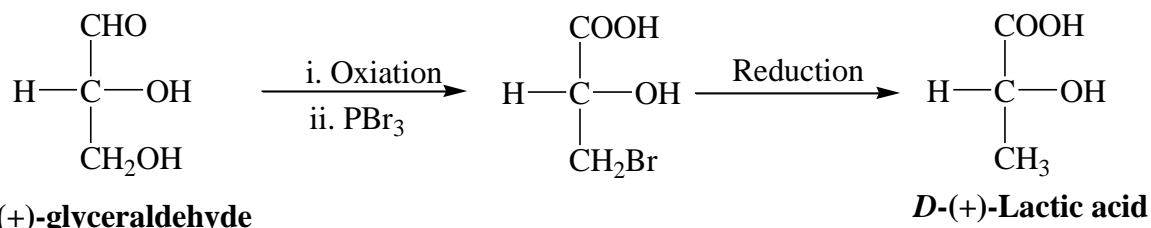

Remember:

- There is no correlation between the *D* and *L* designation and the sign of rotation. *D* form of isomer may be levorotatory, and *L* form of isomer may be dextrorotatory and vice versa.
- The *D/L* nomenclature is limited to the compound that can be prepared or converted from the glyceraldehyde.
- It is limited to only one chiral atom.

6.10.2 *R/S* nomenclature:

Since you have been noted from the above discussion on *D/L* configuration, there are several drawbacks associated with the *D/L* nomenclature system. Hence a definite and universally applicable nomenclature system was needed to specifying the absolute configuration of each chiral centre in a molecule. Cahn and coworkers (1956, 1966) have proposed a new and universally applicable nomenclature pattern for the determination of absolute configuration of any chiral molecule. This is known as the *R/S* system or Cahn-Ingold-Prelog (*CIP*) nomenclature. It involves following two steps.

- In first step we need to assign the priority to the four different atoms/groups attached to a chiral centre.
- Priorities to the groups/atoms can be assigned as per the sequence rule.
- After assigning the priority to the atoms/groups attached to the chiral centre, the molecule is oriented in such a way that the lowest priority group is directed away to the observer.
- Now the arrangement of the remaining atoms/groups is viewed by following decreasing order of priorities from highest priority to lowest priority.

- While viewing the atoms/groups in their decreasing order if your eyes follow the clockwise direction then the chiral centre will have *R* configuration; whereas if your eyes follow anticlockwise direction the chiral centre will have *S* configuration.
- When a molecule has two or more than two chiral centres then the same process should be followed to assign their configuration.

6.10.3 Sequence rule:

To assign the priorities to all four different groups/atoms attached with the chiral centre following sequence rule should be followed. The sequence rule is given by the three scientists Cahn-Ingold-Prelog therefore it is also called the CIP rule. The sequence rules are arbitrary but consistent. The main observations of sequence rules are listed below.

1. If all the atoms directly attached to the chiral centre are different, the sequence of priorities is determined by their atomic number. The atom with higher atomic number is given higher priority. If two atoms are isotopes of same element, the isotope with higher mass number has the higher priority.

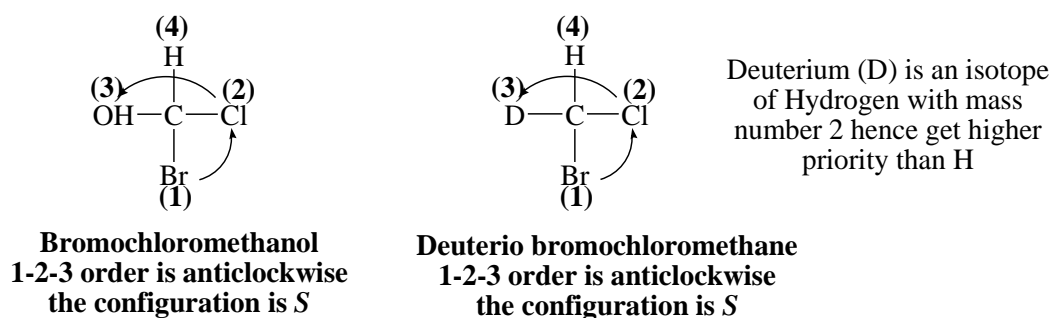

2. If two or more atoms attached to the chiral centre having same atomic number, the priorities are assigned by comparing the atomic numbers of the next atoms attached to each group/atom.

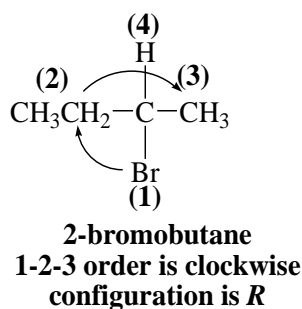

3. If the atoms or groups attached to the centre atom are further linked with some other atoms via double and triple bonds. Then the double or triple bonded atoms are considered to be

duplicated or triplicated. As per sequence rule the triple bond gets priority over double bond, similarly double bond gets priority over single bond.

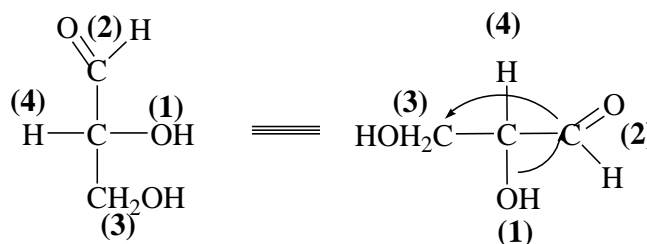

2,3-dihydroxypropanal
1-2-3 order is anticlockwise
configuration is S

6.11 SUMMARY

- Stereochemistry is all about the 3 Dimensional spatial aspects of chemistry.
- Molecules that differ only in the arrangement of bonds in 3Dimensional space are called "stereoisomers"
- Many objects (including molecules) are non-differentiable from their mirror images, but other objects, such as your left and right hands, are differentiable. An object that has a non-superimposable mirror image is said to be "chiral" (Greek = "handedness") and one that has a superimposable mirror image is called "achiral".
- Pairs of molecules that are non-superimposable mirror images of each other are called "enantiomers"
- The most common type of "chirality" is observed when a carbon atom has four different groups attached to it. This carbon atom is then described as a chiral or asymmetric or stereogenic center. This later term can also be contracted to a stereocenter.
- Enantiomers have the same chemical and physical properties (melting points, boiling points, heat of combustion etc.), except for their interaction with plane polarized light or with other chiral molecules (reagents, solvents, catalysts, etc). (Think about how your feet feel if you put them in the wrong shoes).
- Diastereomers are stereoisomers that are not enantiomers.
- The differing interaction with plane polarized light gives rise to optical activity. Enantiomers cause the plane of polarized light to rotate in opposite directions, but to

the same extent (clockwise = +ve, counterclockwise = -ve). This can be measured using a polarimeter. An achiral molecule is optically inactive.

- A 50:50 mixture of a pair of enantiomers is called a racemic mixture. This is optically inactive since the rotations produced by each of the enantiomers must cancel each other out.
- If there is more of one enantiomer than the other, then the optical purity of a sample can be determined by measuring the rotation and comparing it to that of a pure enantiomer. This can be used to establish the enantiomeric excess (ee) of the mixture.
- Despite what one may observe, most molecules are not 2D objects, they are 3D as a result of the spatial arrangement of the atoms, groups and bonds. The interaction of molecules (reactions) which occur as the result of collisions between these 3D objects in 3D space can therefore also have 3D requirements and characteristics. Stereochemistry is all about the 3D properties of molecules and reactions.

6.12 TERMINAL QUESTION

1. What do you understand by Isomerism? Give its types.
2. What is chirality? Explain the necessary condition for a molecule to be chiral.
3. What do you understand by optical activity? How is it measured?
4. What are enantiomers and diastereomers?
5. What are symmetry elements? How they affect optical isomerism?
6. Explain relative and absolute configuration.
7. What is racemization?

ANSWERS

Ans. 1. When two or more compounds having the same molecular formula but difference in their chemical and/or physical properties are called isomers and the phenomenon is known as isomerism. Isomerism has following types:

- a. Structural (constitutional) Isomerism
- b. Stereo (configurational) Isomerism

Ans. 2. An organic compound with four different atoms/groups attached to center carbon and have non-superimposable mirror image is called chiral compound and the phenomenon is called chirality. The presence of four different atoms/groups attached to center carbon and absence of any kind of element of symmetry are the necessary condition for a molecule to be chiral.

Ans. 3. The tendency of an organic compound to rotate the plane polarized light towards left or right hand direction is called optical activity. Optical activity of any compound is measured by analyzing the sample in an instrument called **Polarimeter**. A solution of known concentration of optically active compound is when exposed to the beam of plane polarized light, the beam of plane polarized light is rotated through a certain number of degrees, either to the clockwise (right) direction or anti-clockwise (left) direction. The compound which rotates the plane polarized light towards clockwise direction is called to be **dextrorotatory** (represented by +); whereas, the compound which rotates the plane polarized light towards anti-clockwise direction is called to be **levorotatory** (represented by -).

Ans. 4. Optically active chiral compounds that are non-superimposable mirror image of each other are called enantiomers. Whereas, optically active compounds which are non-mirror image of each other are called diastereomers.

Ans. 5. Elements of symmetry are a simple tool to identify whether a molecule is chiral or not. The necessary condition for optically active molecule to be chiral is that, the molecule should not possess any kind of symmetry elements. The elements of symmetry are generally categorized as follows:

- (i) Simple axis of symmetry (C_n)
- (ii) Plane of symmetry (σ)
- (iii) Centre of symmetry (C_i)
- (iv) Alternating axis of symmetry (S_n)

Optically active compound should not have any kind of symmetry elements.

Ans. 6. Relative and absolute configuration of a compound discusses about the spatial arrangement of atoms/groups around the centre chiral atom. Relative configuration is a comparison of the spatial arrangement of attached atoms/groups of two different chiral centres. Relative configuration is a geometrical property which do not changes on reflection. The absolute configuration is the precise arrangement of atoms in space. The *D/L* system is

usually known as relative configuration whereas, the *R/S* stereo descriptor or nomenclature system for chiral molecules is known as absolute configuration. The absolute configuration is a topographic property which changes on reflection.

Ans.7. The process of conversion of an optically active compound into the racemic mixture/racemate is called *racemization*. The racemization process may take place under the influence of temperature, light or chemical reagents.

6.13 BIBLIOGRAPHY

1. Organic Chemistry Vol. 1 by I L Finar, Published by Pearson Education; ISBN 10: 8177585428.
2. Organic Chemistry by T. W. Graham Solomons, Published by John Wiley; ISBN-10: 1118133579.
3. Stereochemistry of Organic Compounds by Ernest L. Eliel; Published by John Wiley; ISBN- 0-471-01670-5
4. Organic Chemistry by Leroy G. Wade. Published by Pearson Education; ISBN- 9780321768414

UNIT 7: STEREOCHEMISTRY-II

CONTENTS:

- 7.1 Introduction
- 7.2 Objectives
- 7.3 Geometrical isomerism
 - 7.3.1 Determination of configuration of geometrical isomers
 - 7.3.2 E & Z system of nomenclature
 - 7.3.3 Geometrical isomerism in oximes and acyclic compounds
- 7.4 Conformational analysis of ethane and n- butane
 - 7.4.1 Conformational analysis of ethane
 - 7.4.2 Conformational analysis of n-butane
- 7.5 Conformation of cyclohexane
- 7.6 Axial and equatorial bond
- 7.7 Conformation of mono substituted cyclohexane
- 7.8 Newman projection and Sawhorse formula
- 7.9 Fischer and flying wedge formula.
- 7.10 Difference between configuration and conformation.
- 7.11 Summary
- 7.12 Terminal Question
- 7.13 Bibliography

7.1 INTRODUCTION

In Unit 4 we have discussed about the isomerism and its type. The difference between structural and stereoisomerism is also drawn in that Unit. However, more detail discussion on optical isomerism and its related components is presented in Unit 4. In present unit (UNIT 5) we will learn more about the isomerism exhibited by the; 1) Molecule with restricted rotation around carbon-carbon bonds (olefinic and cyclic organic compounds) is known as geometrical isomerism and; 2) Molecules which are readily interconvertible due to rotation about single bond is known as conformational isomerism. The geometrical isomerism comes under stereoisomerism whereas the conformational isomerism comes under structural isomerism. Partly, we have also discussed about stereoisomerism and structural isomerism in Unit 6.

7.2 OBJECTIVES

After completing this unit learner will be able to

- Learn about the stereoisomerism of those organic compounds which are not optically active
- Understand the geometrical isomerism shown by olefinic compounds (double bonded compounds)
- Understand the conformational isomerism and its representation
- Make a difference between configurational and conformational isomers
- Learn about the conformational analysis of aliphatic and cyclic hydrocarbons
- Learn how to write the Fischer projection formulae, flying wedge formula, Newman projection formulae and Sawhorse projection formulae for various conformational and configurational isomers.

7.3 GEOMETRICAL ISOMERISM

Geometrical isomerism is generally observed in alkenes and cyclic compounds due to their restricted rotation around carbon-carbon bond. The rotation about a double bond in alkene or about a single bond in a cyclic/ring like compound is restricted. Double bonded system consists of a σ (sigma) and a π (pi) bond perpendicular to each other. It is not possible to rotate the molecule about carbon-carbon bond. The rotation will break the π bond as a result the molecule will lose its identity. In some cases the rotation about single bond is also restricted due to steric hindrance. Geometrical isomerism is shown by various groups of compounds the major class of compounds that exhibit geometrical isomerism are classified as:

i. Compounds having double bond;

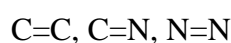

For example *cis*- and *trans*-2-butene have same connection of bond and molecular formulae.

☞ If you observe two similar groups are on the same side of C=C bond this is called *cis*-isomer; whereas, if two similar groups are on opposite side of C=C bond this is known as *trans*-isomer.

Example 1: *cis*- and *trans*- isomerism in 2-butene

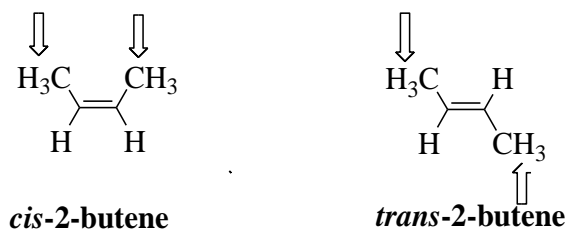

☞ You can understand that due to the presence of one σ (sigma) and one π (pi) bond in carbon-carbon double bond, rotation around C=C bond is not possible. The restricted rotation around C=C bond is responsible for geometrical isomerism in alkenes.

ii. Cyclic compounds like homocyclic, heterocyclic and fused-ring systems

You can easily observe that rotation around C-C bond is also not possible in cyclic compounds as the rotation would break the bonds and break the ring. Thus Geometrical isomerism is also possible in cyclic compounds.

Example 2: *cis*- and *trans*- isomers of 1,2-dimethylcyclopropane

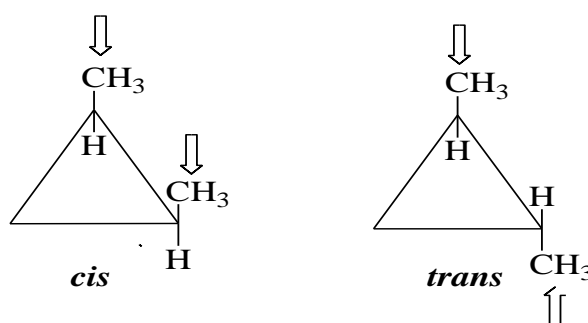

Conditions for geometrical isomerism:

Following two conditions are necessary for any compounds to show geometrical isomerism

- There should be restricted (not allowed) rotation about a bond in a molecule.
- Both substituents/atoms on each carbon about which rotation is not allowed should (restricted) be different.

☞ **Remember:** Geometrical isomers are non-mirror image of each other hence they are called diastereomers. Therefore their physical and chemical properties are different.

☞ Triple bonded molecules do not exhibit any kind of stereoisomerism because such molecule shows cylindrical symmetry.

7.3.1 Determination of the configuration of geometrical isomers:

Unlike stereoisomerism of chiral compounds there is no general method for determining the configuration of geometrical isomers. You can find several methods for determination of configuration of geometrical isomers. Depending on the nature of compounds you can apply one or more methods for determination of configuration of geometrical isomers. The most commonly used methods are as follows:

- 1) Physical method
- 2) Cyclization method
- 3) Method of conversion into compound of known configuration

1) Physical method for determination of configuration:

The geometrical isomers are non-mirror image of each other hence are called diastereomers. We have discussed in Unit 6 that diastereomers have different physical and chemical properties. Based on this fact, we can determine the configuration of geometrical isomers by comparing their physical properties. For example the melting point and absorption intensity of the *cis*-isomer are lower than the *trans*-isomer. Similarly the boiling point, solubility, heat of hydrogenation, density, refractive index, dipole moment and dissociation constant of *cis*-isomer is greater than the *trans*-isomer.

Thus if you have a set of geometrical isomers, then by comparing their above mentioned physical properties you can assign their configuration (means you can identify the *cis*- and *trans*-isomers).

Example 3: Diethyl maleate and diethyl fumarate are the *cis*- and *trans*- form to each other. The configuration of these can be determined by comparing their dipole moment. The dipole moment of diethyl maleate is 2.54D whereas the dipole moment of diethyl fumarate is 2.38D. Based on the fact that the dipole moment of *trans*- form of an isomer is lower than that of *cis*-form, you can easily predict the *cis*- and *trans*- form for diethyl maleate and diethyl fumarate.

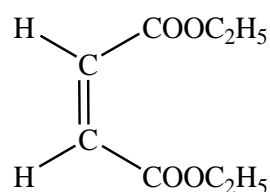

diethyl maleate

dipole moment = 2.54D

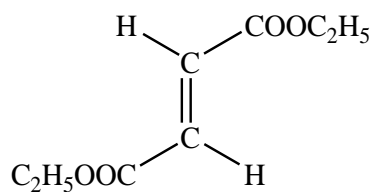

diethyl fumarate

dipole moment = 2.38D

Example 4: *cis*- and *trans*- form of crotonic acid can be differentiated on the basis of their melting points. *cis*- isomer have lower melting point in comparison to *trans*- isomer.

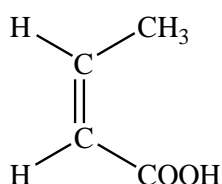
*cis*-crotonic acid

melting point = 15.5°C

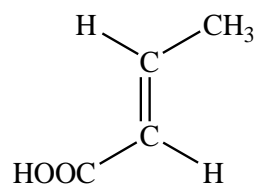
*trans*-crotonic acid

melting point = 72°C

Example 5: Ethylbutenoate exists in *cis*- and *trans*- isomeric forms. Both, the forms can also be differentiated based on their melting points.

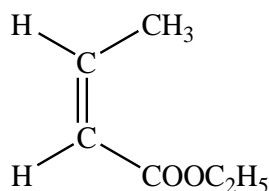
*cis*-ethylbutenoate

boiling point = 56°C/10mm

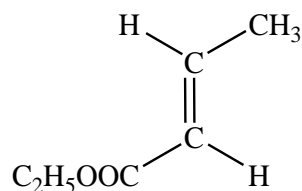
*trans*-ethylbutenoate

boiling point = 61°C/10mm

Example 6: *cis*- and *trans*- isomer can also be identified on the basis of their absorption intensities. The UV absorption intensity (λ_{\max}) of *cis*-stilbene is lower than that of *trans*-stilbene.

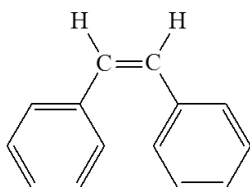
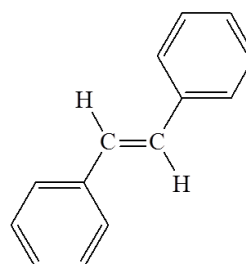
*cis*-stilbene $\lambda_{\max} = 278$ *trans*-stilbene $\lambda_{\max} = 294$

2) Cyclization method:

Cyclization within a molecule (intramolecular) is usually depends upon the distance of two associating groups of a molecule. In other words if the reacting groups are closer to each other than the intramolecular cyclization takes place more effectively. This principal is also helps to identify the configuration of geometrical isomers.

Let us take an example of two geometrical isomer of Butenedioic acid (*i.e.* Maleic acid and Fumaric acid) can be differentiated by possibility of formation of anhydride. Maleic acid which is *cis*- form of Butenedioic acid can only give the respective anhydride on heating; whereas, the *trans*- form of Butenedioic acid (*i.e.* Fumaric acid) does not give its anhydride on heating. If the Fumaric acid is strongly heated it get converted into Maleic acid.

Example 7: Cyclization of Maleic acid to Maleic anhydride. Fumaric acid does not give the anhydride on heating.

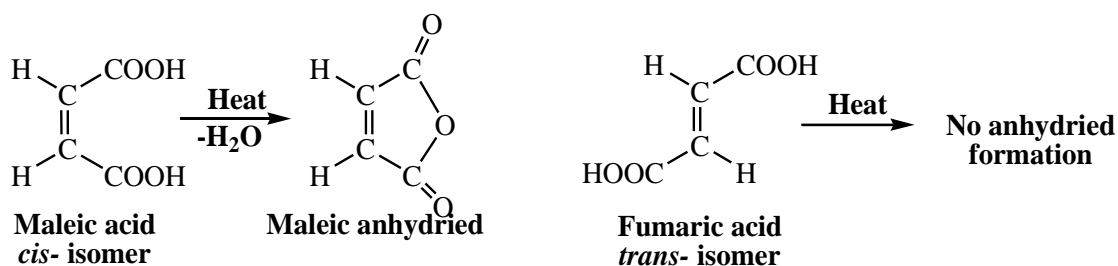

3) Method of conversion into compound of known configuration:

The configuration of geometrical isomers can also be determined by converting them in to a compound of known configuration. For example, there are two trichlorocrotonic acid (*cis*- and *trans*-), one of which can be hydrolyzed to Fumaric acid. Therefore this isomer must be *trans*- isomer of trichlorocrotonic acid. The *cis*- isomer does not undergo hydrolysis.

Example 8: Determination of configuration of two isomers of trichlorocrotonic acid by hydrolysis method.

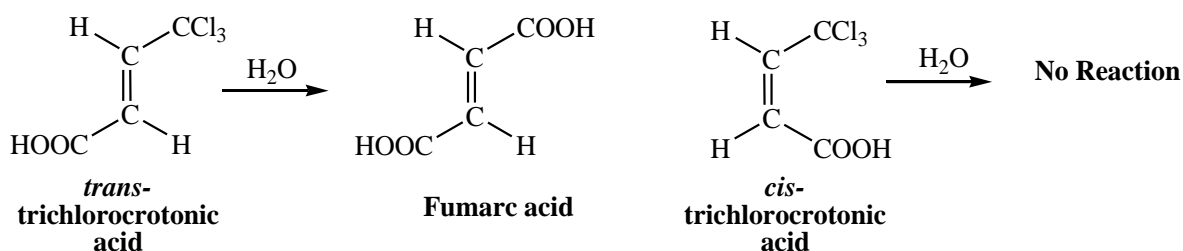

Example 9: Reduction of trans-crotonaldehyde in to trans-crotyl alcohol

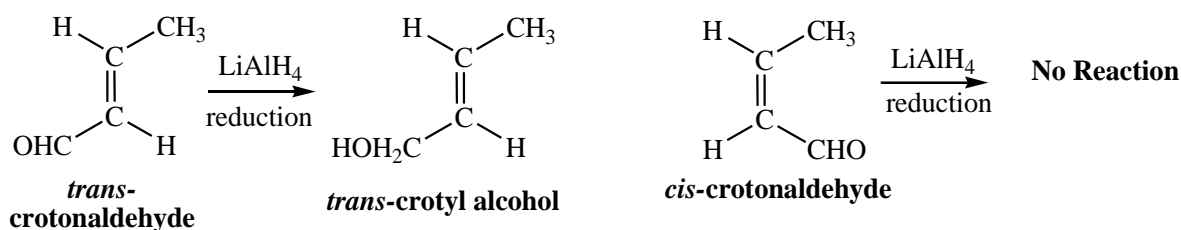

7.3.2 E & Z system of nomenclature:

We have already discussed about the *cis*- and *trans*- nomenclature of geometrical isomerism. The *cis*- and *trans*- nomenclature is the oldest and most fundamental nomenclature system for geometrical isomerism. The *cis*- and *trans*- nomenclature system is applicable only for those geometrical isomers in which at least one identical atoms/groups is bonded with each double bonded carbon. If both the identical groups/atoms are on same side of double bond the isomer is called as *cis*- isomer; whereas, if both identical groups/atoms are on opposite side of the double bond the isomer is called as *trans*- isomer (see example 1 of this unit).

The *cis*- and *trans*- nomenclature method is limited to the molecule in which identical groups/atoms are attached to double bonded carbon. If all the atoms/groups on double bonded carbon are different then the configuration of such molecule could not be assigned as *cis*- and *trans*- nomenclature. A more general nomenclature (*i.e.* E/Z nomenclature) was introduced which was based on Cahn-Ingold-Prelog system. In E/Z system the configuration is specified by the relative positions of two highest priority groups/atoms on the two carbons of the double bond. Let us understand the E/Z nomenclature system by considering an example which we have already discussed in the beginning of this Unit (example 1).



You can easily identify which one is *cis*- isomer and which one is *trans*- just by looking the position of similar atoms/groups. It is a simple and visual way of telling the two isomers apart. *So why do we need another system?* Now consider one another example in which we will change all the atoms/groups in above example by replacing one CH₃- by Br, other CH₃- by Cl, and one H- by F. Now try to predict the nomenclature of these two isomers of 2-

bromo-1-chloro-1-fluoroethene (I and II). Could you name these isomers using *cis-* and *trans-* nomenclature? The simplest answer is 'NO'.



Because everything attached to the carbon-carbon double bond is different, there are not so simple so that you can predict them as *cis-* and *trans-* to each other. The E/Z system of nomenclature provides the most appropriate solution to above problem. This system is based on the priority of the attached atoms/groups on each double bonded carbon. The priority of the atoms/groups can be assigned as per the 'Sequence Rule' or 'CIP Rule' given by Cahn-Ingold-Prelog. We have already discussed the detail about 'Sequence Rule' in Unit 4. Now assign priority to atoms/groups attached to each double bonded carbon in above example.

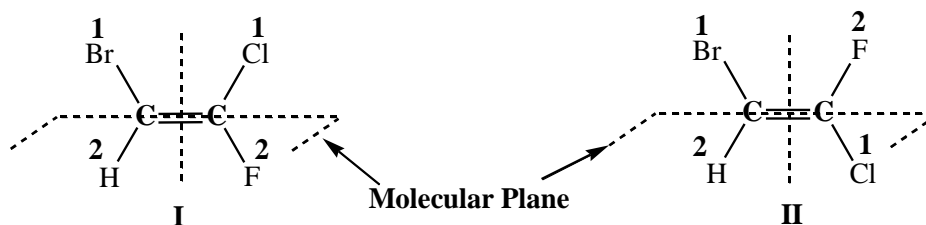

We can easily observe that the both higher priority atoms/groups on each double bonded carbon of isomer **I** are on same side; whereas, the higher priority atoms/groups on each double bonded carbon of isomer **II** are on opposite side. If the two groups with the higher priorities are on the same side of the double bond, such isomer is designated as the (*Z*)-isomer. So you would write it as (*Z*)-name of compound. The symbol *Z* comes from a German word *ZUSAMMEN*, which means together. If the two groups with the higher priorities are on opposite sides of the double bond, then such isomer is designated as (*E*)-isomer. *E* comes from the German *ENTGEGEN*, which means opposite. Thus in given example the isomer **I** is having both higher priority groups/atoms are on same side of double bond, hence it is *Z*- isomer; whereas, the isomer **II** is having both higher priority groups/atoms are on opposite side of the double bond, hence it is *E*- isomer.

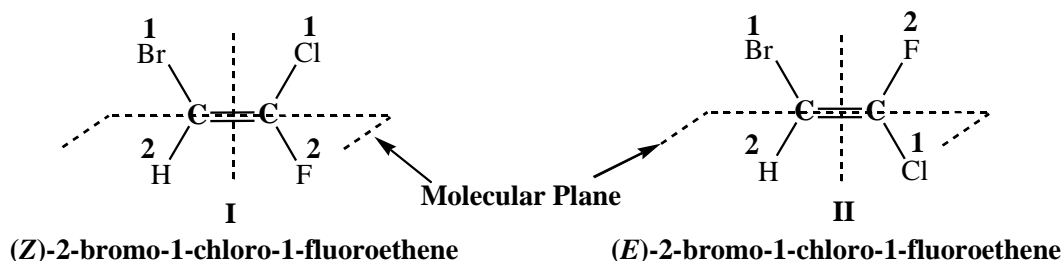

Example 10: Some other examples of geometrical isomers with *E* and *Z* configuration

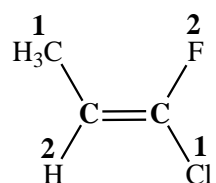

(E)-1-chloro-1-fluoroprop-1-ene

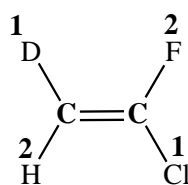

(E)-Deuterated 1-chloro-1-fluoroprop-1-ene

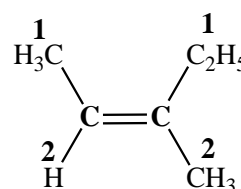

(Z)-3-methylpent-2-ene

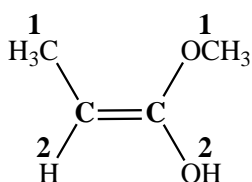

(Z)-1-methoxyprop-1-en-1-ol

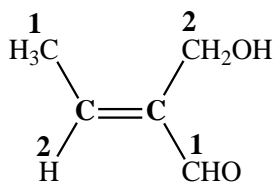

(E)-2-(hydroxymethyl)but-2-enal

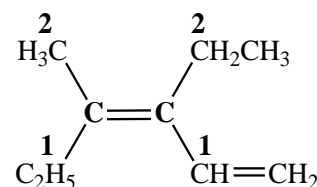

(Z)-3-ethyl-4-methylhexa-1,3-diene

7.3.3 Geometrical isomerism in oximes and acyclic compounds:

Nitrogen containing compounds like $>C=N-$ as well as $-N=N-$ bond also exhibit geometrical isomerism. The important classes of compounds that exhibit geometrical isomerism due to $>C=N-$ bond are:

- (a) Oximes
- (b) Nitrones
- (c) Semicarbazones
- (d) Hydrazones

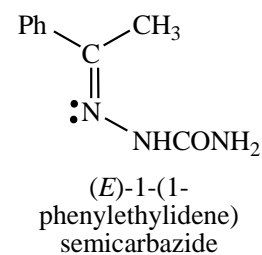
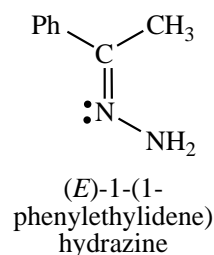
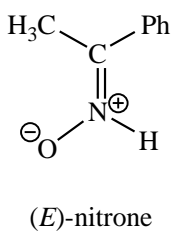
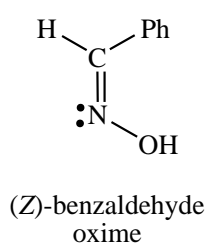

Oximes are the most common compounds among all above classes. Both carbon and nitrogen atom in oxime are sp^2 hybridized the C=N bond of oxime consists a sigma (σ) and a pi (π) bond. Therefore, there is no free rotation possible around C=N bond; hence, oximes of aldehyde and ketones (unsymmetrical) exhibit geometrical isomerism. The configuration of such compounds is also based on priority of the groups/atoms attached to the double bonded carbon and nitrogen. Lone pair of the nitrogen always considered to be the lowest priority group. The priority of the groups/atoms is assigned as per the sequence rule which we have already discussed in Unit 6. If the higher priority groups/atom on double bonded carbon and nitrogen are on same side of the double bond the isomer is considered as *Z*- isomer, whereas if the higher priority groups/atoms are on opposite side the isomer is considered as *E*- isomer.

Example 11: E/Z isomerism is shown by i) benzaldoxime, ii) ethylmethylketoxime and iii) methylphenylketoxime

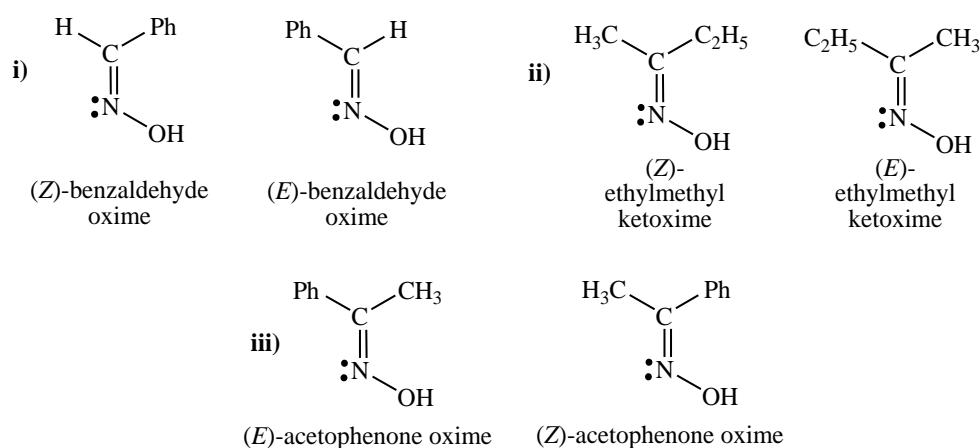

We have already discussed that the geometrical isomerism usually arises due to restricted rotation about a bond. Since, there is no rotation possible about the carbon-carbon bond in a cyclic compound or cycloalkanes like cyclopropane, cyclobutane, cyclopentane, cyclohexane, etc. Hence, such molecule also exhibit geometrical isomerism, and can be designated as *cis*- and *trans*- isomer. In a disubstituted cycloalkanes, where the two atoms/groups are bonded on different carbons, can be represented in to two geometrical isomers. The isomer in which the two atoms/groups are located on the same side of the ring is called *cis*-isomer; whereas, the isomer in which the two atoms/groups are located on the opposite side of the ring is called *trans*-isomer.

Example 12: Geometrical isomers of disubstituted cyclopropane, cyclobutane, cyclopentane and cyclohexane.

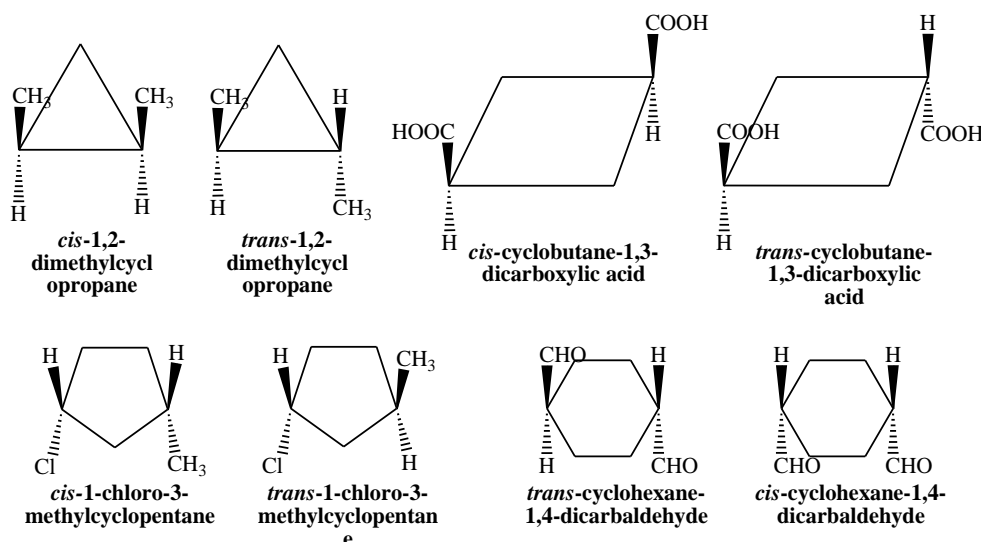

7.4 CONFORMATIONAL ANALYSIS OF ETHANE AND *N*-BUTANE

The different spatial arrangements of atoms in a molecule which is readily interconvertible by rotation about single bonds are called **conformations**. The study of various preferred conformations of a molecule and the correlation of physical and chemical properties to the most preferred conformer is called conformational analysis. Due to rapid interchange of the spatial positions of groups/atoms these conformers are non-separable under normal conditions. Since, different conformations arise because of the rotation about single bonds, hence, they are also called the rotamers. The conformational and configurational isomerisms are related to energy barrier for interconversions of different spatial arrangements of atoms in a molecule. If the energy barrier for interconversion of different spatial arrangements is between 0.6 kcal/mol-16.0 kcal/mol; it results the conformational isomers or conformers; whereas, if this energy barrier is more than or equal to 16 kcal/mol than the configurational isomers are obtained.

7.4.1 Conformational analysis of ethane:

When ethane molecule rotates around carbon-carbon single bond, two extreme conformations (one is highly stable and other is highly unstable) are obtained. The highly stable conformation of ethane is called '*staggered conformation*' and the highly unstable conformation of ethane is called '*eclipsed conformation*'. In between these two extreme conformations (*i.e.* staggered and eclipsed), an infinite number of conformations are also possible.

7.4.1.1 Staggered conformation: A conformation with a 60° dihedral angle is known as staggered conformation. The angle between the atoms attached to the front and rear carbon atom is called dihedral angle.

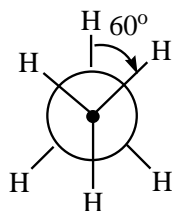

Staggered conformation

7.4.1.2 Eclipsed conformation: A conformation with a 0° dihedral angle is known as eclipsed conformation.

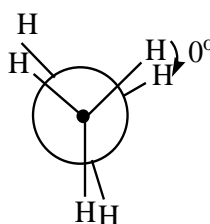

Eclipsed conformation

In staggered conformation the atoms are located at maximum possible distance from each other hence they are in their most relaxed spatial arrangement thus the staggered conformation is considered as the most stable conformation; whereas, in eclipsed conformation the atoms are located at minimum distance, hence due to repulsion between the atoms the eclipsed conformation is considered as the least stable (high energy) conformation. There are two methods for the representation of staggered and eclipsed conformations, a) the Sawhorse representation formula and b) the Newman representation formula.

- a) The Sawhorse representation formula: In sawhorse representation formula the spatial arrangement of all the atoms/groups on two adjacent carbon atoms. The bond between adjacent carbon atoms is represented by a diagonal line and rest of the atoms are located on each carbon at $+120^\circ$ or -120° angles to each other. The sawhorse representation is shown as:

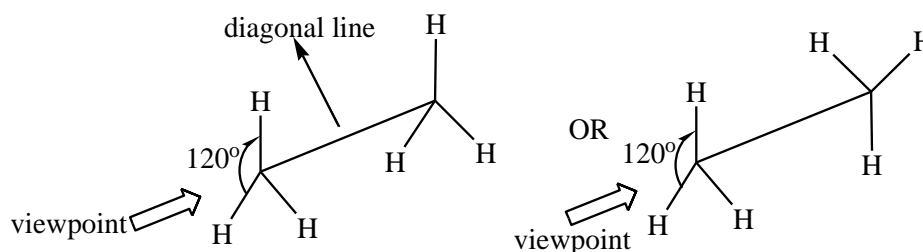

Sawhorse representation formula

- b) The Newman representation formula: The Newman representation formula is a planar representation of the sawhorse formula. The molecule is viewed along the axis of a carbon-carbon bond. The carbon atom in front of the viewer is represented by a dot (\bullet), whereas the carbon atom away to the viewer is represented by circle. The rest of the atoms/groups are located on each carbon atoms at $+120^\circ$ or -120° angles to each other as shown below:

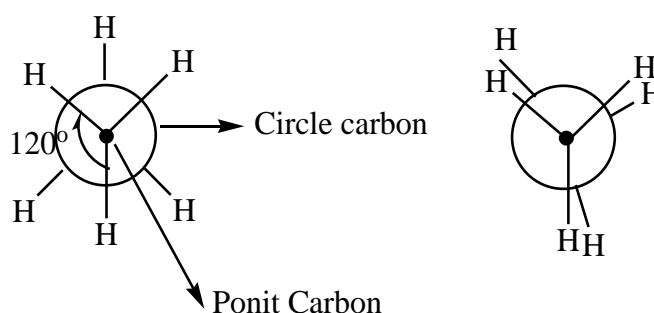

Newman representation formula

The different conformations of ethane are not equally stable. The staggered form in which the hydrogen atoms are 'perfectly staggered' (dihedral angle is 60°) is the most stable conformation. This is because, in this conformation the all carbon hydrogen (C-H) bonds are located at maximum possible distance to each other, and hence they feel minimum repulsive energy from each other. In eclipsed conformation of ethane, the hydrogen atoms attached to each carbon are directly opposing to each other. This result the minimum separation of the atoms or groups, and hence they feel maximum repulsive energy from each other. The eclipsed conformation therefore, of highest energy and has the lowest stability. A graph plot for the energy profile for various conformations of ethane is shown on figure 7.1. The relative stability of various conformations of ethane is Staggered \gg Eclipsed

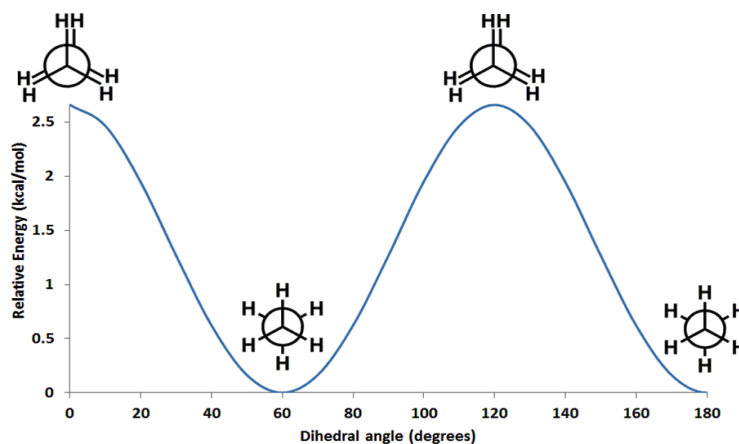

Figure 7.1: Energy profile diagram of conformational isomer of ethane

7.4.2 Conformational analysis of *n*-butane:

n-Butane (C_4H_{10}) has three carbon-carbon single bonds (Figure 7.2); therefore the molecule can rotate about each of them. The rotation about C2 and C3 bond will provide the symmetrical conformations. To study the conformational analysis of *n*-butane, we must consider it as a derivative of ethane molecule, where one hydrogen at each carbon of ethane is replaced by methyl group ($-CH_3$).

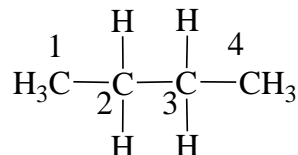

Figure 7.2: Butane molecule

Various conformation of *n*-butane can be obtained by rotation about C2 and C3 bond are shown in figure 7.3:

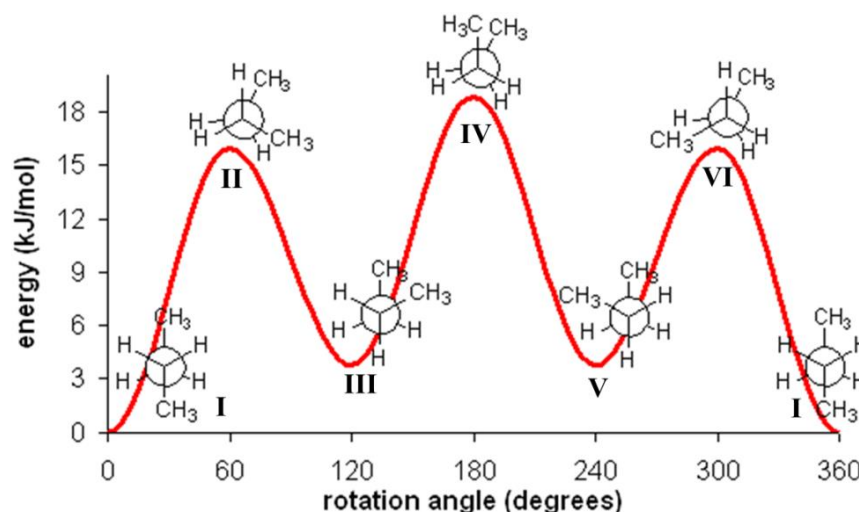

Figure 7.3: Energy profile diagram of conformational isomer of *n*-butane

From figure 7.3, we can see that *n*-butane has three staggered conformations (**I**, **III** and **V**). Conformer **I**, in which two methyl groups are as far as possible, and hence is more stable than other two staggered conformers (*i.e.* **III** and **V**), because conformer **I**, has minimum repulsive energy. As you can see from figure 3; in conformer **I**, both the methyl groups are located opposite to each other. The most stable conformer of *n*-butane, in which both the methyl groups are located opposite to each other is called the *anti-conformer*, whereas other two staggered conformers (*i.e.* **III** and **V**) are called *gauche conformer*. Due to difference in steric strain (repulsion between dihedral atoms/groups) the repulsive energy of *anti* and *gauche* conformers are also different. Three eclipsed conformers (**II**, **IV** and **VI** in figure 7.3) are also exists for *n*-butane, in which the dihedral atoms/groups are in front of each other (*i.e.* dihedral angle is 0°). The fully eclipsed conformer **IV**, in which the two methyl groups are closest to each other, has maximum steric strain; hence it is of higher energy than the other eclipsed conformers (**II** and **VI**). Thus the relative stabilities of the six conformers of *n*-butane in their decreasing order is given as follows:

Anti > Gauche > Eclipsed > Fully eclipsed

I **III and V** **IV** **II and VI**

7.5 CONFORMATION OF CYCLOHEXANE

It is known to you that in cycloalkanes, all the ring carbons are sp^3 hybridized, hence must have tetrahedral geometry with all bond angles of 109.5° . But to sustain its cyclic structure the cycloalkanes could not be able to maintain the bond angle of 109.5° . As a result there is a deviation from the normal tetrahedral bond angle. This deviation leads the development of strain in the molecule. Thus the cycloalkanes exhibit angle strain, due to which cycloalkanes are not as stable as their non-cyclic homologs. To minimize the angle strain the structure of cycloalkanes is keep on changing from one cyclic form to another which are readily interconvertible by rotation about single bond. This is the reason why cyclohexane and larger rings are non-planar.

Cyclohexane exists in two readily interconvertible forms which are called the chair and boat conformations of cyclohexane (Figure 7.4).

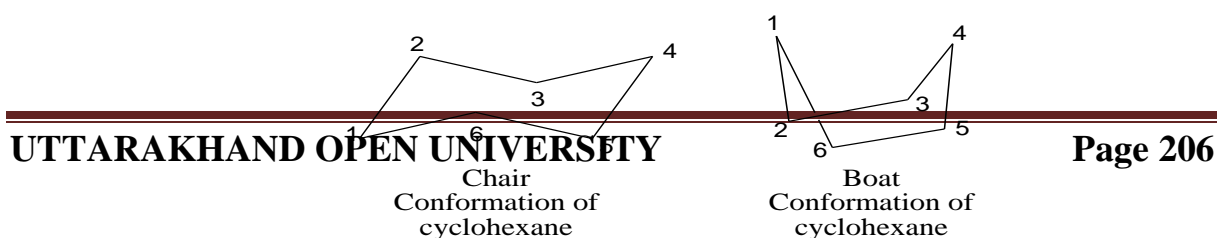
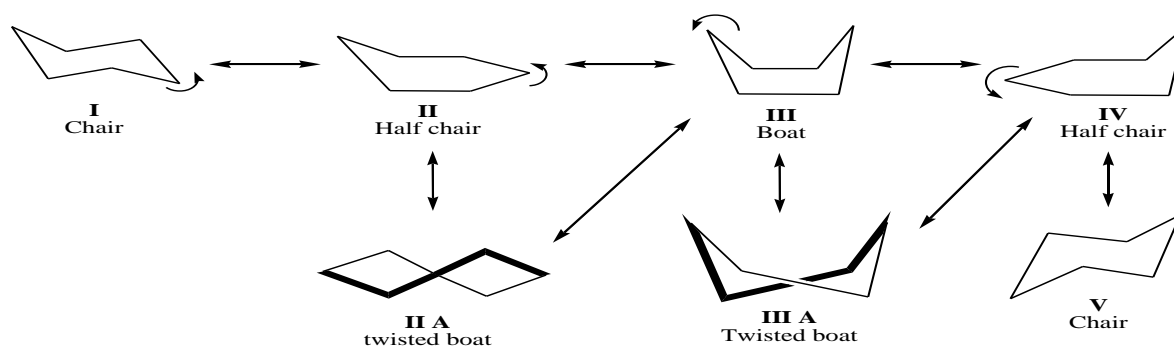

Figure 7.4: Two readily interconvertible conformations of cyclohexane

Both chair and boat forms are free from angle strain. In chair form carbon C1, C3 and C5 are in one plane and carbon C2, C4 and C6 are in different plane. Similarly, in boat form carbon C1 and C4 are in one plane and carbon C2, C3, C5 and C6 are in other plane. The interconversions of chair to boat and boat to chair *via* various other intermediate conformations are shown in scheme 1. The chair conformation (**I** and **V** **scheme 1**) is considered as a rigid conformation of cyclohexane in comparison to boat conformation; because during interconversion from chair to boat conformation, some angular deformations are required. These angular deformations usually increase the energy barrier for interconversion from chair to boat conformation. Therefore the chair conformation of cyclohexane is the most stable conformation.



Scheme 1: Conformational analysis of cyclohexane

Chair form on distortion gives half chair (**II** and **IV** **scheme 1**) conformations which are of highest energy conformations. In comparison to chair conformation, the boat conformation (**III** **scheme 1**) is flexible and can readily distort in to many steps to reduce the C-H bond eclipsing. The boat conformation can be interconvertible in to twisted boat (**IIA** and **IIIA** **scheme 1**) conformations, which has comparatively less angular and steric strains. The twisted boat conformations have lower energy than the boat conformation, hence is more stable than boat conformation. At room temperature 99.9% cyclohexane molecules exist in

the most stable chair conformation. The energy profile diagram along with various possible conformations of cyclohexane is shown in figure 7.5.

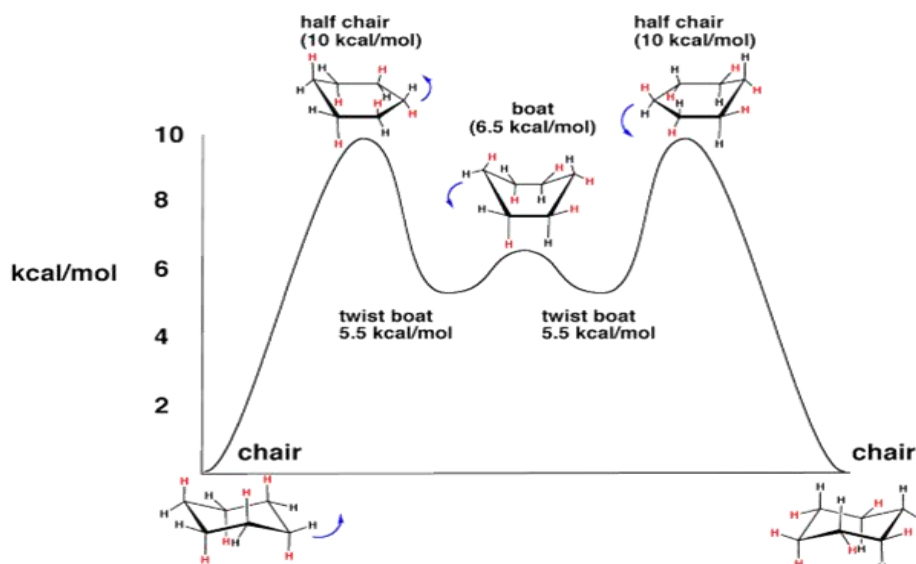
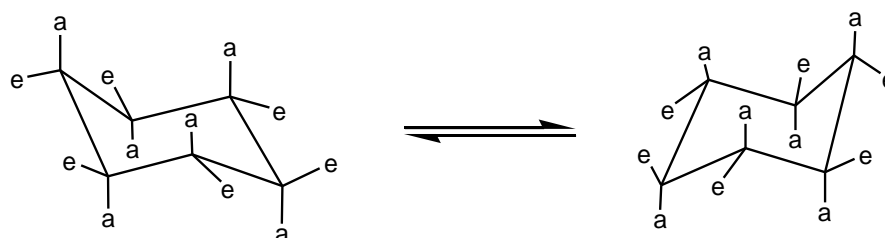

Figure 7.5: Energy profile diagram of conformation of cyclohexane

7.6 AXIAL AND EQUATORIAL BOND

In chair conformation of cyclohexane, there are two different positions occupied by the 12 hydrogen atoms of cyclohexane. Out of total 12 Hydrogen atoms of cyclohexane, six hydrogen atoms are located towards perpendicular to average plane of the ring; these perpendicular hydrogen atoms are called axial hydrogens (*a*), and respective bonds are called *axial* bonds. The other six hydrogen atoms are located along with the average plane of the ring; these hydrogens are called *equatorial* hydrogens (*e*), and the respective bonds are called equatorial bond.



a = axial; e = equatorial

Cyclohexane is rapidly interconvertible (flips) in to its mirror image chair conformations at room temperature. During flipping all the axial hydrogens becomes equatorial and all the equatorial hydrogens becomes axial. The flipping of the cyclohexane is so rapid that it is not

possible to differentiate between equatorial and axial hydrogens. These hydrogens can be differentiated at very low temperature (*i.e.* -80°) and analyzed by ^1H NMR spectroscopy.

7.7 CONFORMATION OF MONO SUBSTITUTED CYCLOHEXANE

If one hydrogen atom of cyclohexane is replaced by a larger atom or group, the molecule becomes highly hindered. As a result the repulsion between atoms increases. Axial atoms/groups usually face more repulsive interaction in comparison to equatorial atoms/groups. Since three axial atoms/groups are located in one side of the average plane of ring, whereas rest three atoms/groups are located in other side of the average plane of ring. The repulsive interaction experienced by three axial atoms is called *1,3-diaxial interaction*. To minimize the 1,3-diaxial interaction and resulting repulsive energy, the monosubstituted cyclohexane acquires a chair conformation in which the substituents occupies an equatorial position. There are two possible chair conformations for methyl cyclohexane. In one conformation the methyl group located at axial position (**I**), whereas in other conformation the methyl group is located at equatorial position (**II**). When methyl group is at axial position, it has 1,3-diaxial interaction with hydrogen atoms at C3 and C5 carbons due to which the energy of such conformation is very high in comparison to the conformer in which the methyl group is at equatorial position. The conformer with methyl group at equatorial position does not have any kind of 1,3-diaxial interaction hence is more stable.

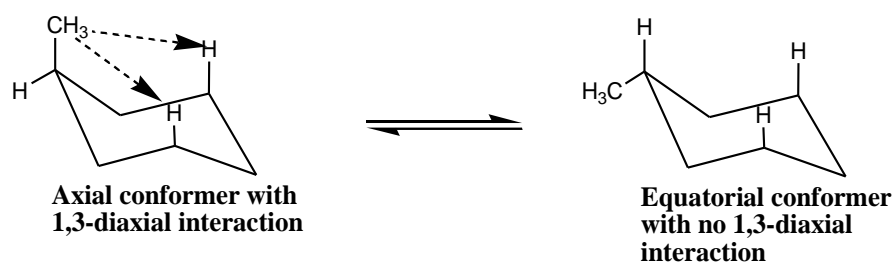

7.8 NEWMAN PROJECTION AND SAWHORSE FORMULA

The Newman representation formula: Newman Projections are used mainly for determining conformational relationships. Recall that, conformers are molecules that can be converted into one another by a rotation around a single bond. Newman Projections are also useful when studying a reaction involving prochiral molecules that have a double bond, in which the addition of a new group creates a new stereocenter. In this notation, you are

actually viewing a molecule by looking down a particular carbon-carbon bond. The Newman representation formula is a planar representation of the sawhorse formula. The molecule is viewed along the axis of a carbon-carbon bond. The carbon atom in front of the viewer is represented by a dot (\bullet), whereas the carbon atom away to the viewer is represented by circle. The rest of the atoms/groups are located on each carbon atoms at $+120^\circ$ or -120° angles to each other as shown below:

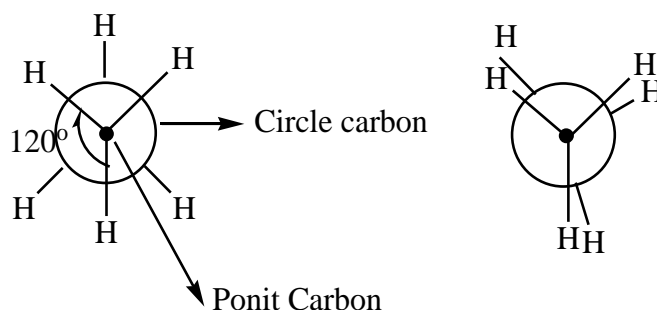

Newman representation formula of ethane

Addition of more carbons makes Newman Projections more complicated. For example, Newman Projections can be made for butane, such that it's eclipsed, gauche, and anti-conformations can be seen. (Recall that these three forms of butane are conformational isomers of one another.) In this case, the front dot represents the second carbon in the butane chain, and the back circle represents the third carbon in the butane chain. The Newman Projection condenses the bond between these two carbons.

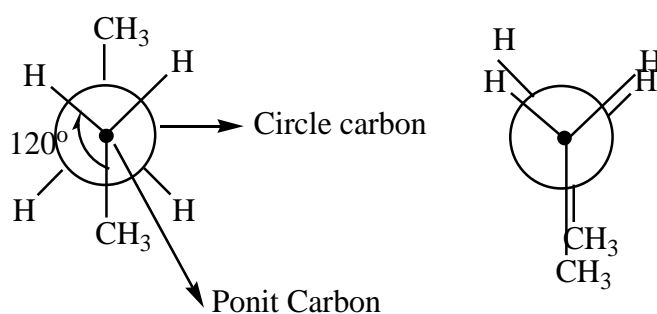

Newman representation formula of butane

The Sawhorse representation formula: Sawhorse Projections are very similar to Newman Projections, but are used more often because the carbon-carbon bond that is compressed in a Newman Projection is fully drawn out in a Sawhorse Projection. When properly laid-out, Sawhorse Projections are useful for determining enantiomeric or diastereomeric relationships between two molecules, because the mirror image or superimposability relationships are clearer. Like with Newman Projections, a Sawhorse Projection is a view of a molecule down

a particular carbon-carbon bond, and groups connected to both the front and back carbons are drawn using sticks at 120 degree angles. Sawhorse Projections can also be drawn so that the groups on the front carbon are staggered (60 degrees apart) or eclipsed (directly overlapping) with the groups on the back carbon. Below are two Sawhorse Projections of ethane. The structure on the left is staggered, and the structure on the right is eclipsed. These are the simplest Sawhorse Projections because they have only two carbons, and all of the groups on the front and back carbons are identical. The sawhorse representation formula is the spatial arrangement of all the atoms/groups on two adjacent carbon atoms. The bond between adjacent carbon atoms is represented by a diagonal line and rest of the atoms are located on each carbon at $+120^\circ$ or -120° angles to each other. The sawhorse representation is shown as:

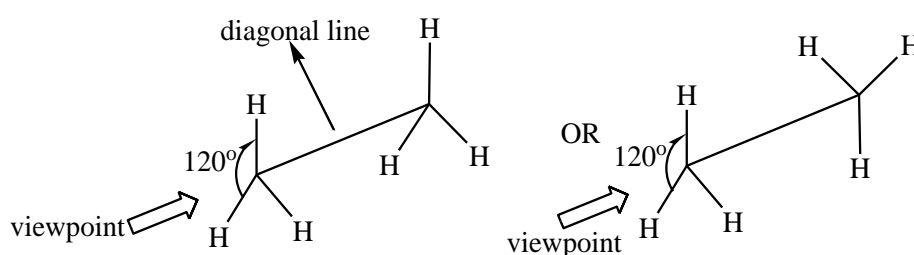

Sawhorse representation formula of ethane

Addition of more carbons makes Sawhorse Projections slightly more complicated. Similar to Newman Projections, Sawhorse Projections can also be made for butane, such that it's eclipsed, gauche, and anti-conformations can be seen. (Recall that these three forms of butane are conformational isomers of one another).

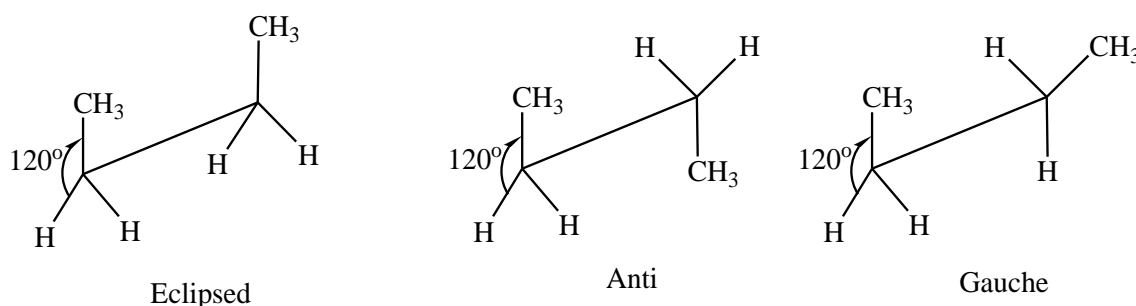

Sawhorse representation formula of butane

7.9 FISCHER AND FLYING WEDGE FORMULA

The sp^3 hybridized tetrahedral carbon is three dimensional in nature. Generally it is very difficult to represent a three dimensional structure in a two dimensional plane paper. There are many methods have been developed for two dimensional representation of a three

dimensional structure. Out of them the flying-wedge and Fischer representation methods are most commonly used for two dimensional representation of a three dimensional structure.

The flying-wedge: This is the most commonly used model for the two dimensional representation of a three dimensional molecule. In this model the bonds are presented in continuous, solid thick and dashed lines. A solid thick line represents a bond projecting above the plane of the paper; it is considered that the bond with solid thick line is pointing towards observer. A dashed line represents a bond below the plane of the paper; it is considered that the bond with dashed line is pointing away to the observer. The bonds with continuous lines represent the bonds in the plane of paper. Let us consider an example of *R*-Lactic acid and *S*-Lactic acid.

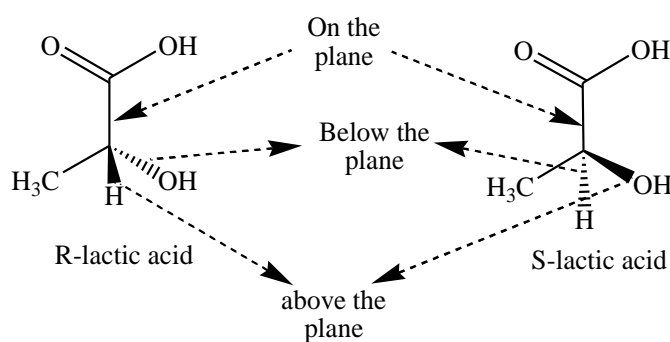

Flying-wedge representation of *R*- and *S*-Lactic acid

Fischer projection formula: It is a simplification of flying-wedge representation, in Fischer projection formula all bonds are drawn as solid lines in a plane paper. Fischer Projections are used often in drawing sugars and hydrocarbons, because the carbon backbone is drawn as a straight vertical line, making them very easy to draw. When properly laid-out, Fischer Projections are useful for determining enantiomeric or diastereomeric relationships between two molecules, because the mirror image relationship is very clear. In a Fischer Projection, each place where the horizontal and vertical lines cross represents a carbon. The vertical lines are actually oriented away from you (similar to dashes in the Wedge-Dash Notation) and the horizontal lines are oriented toward you (similar to wedges in the Wedge-Dash Notation).

Fischer projection is not as demonstrative as flying –wedge representation. It does not represent the actual shape of the molecule. Usually the Fischer projection formula is drawn so that the longest carbon chain in the molecule is vertical with the highly oxidized group on the top.

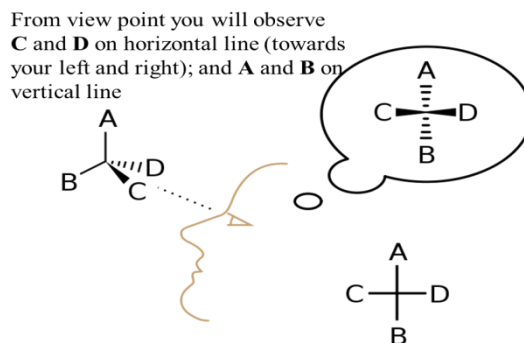

Let us consider an example for conversion of flying-wedge formula to Fischer projection formula for *R*- and *S*- Lactic acid.

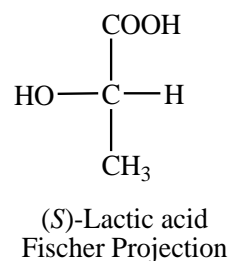
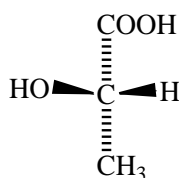
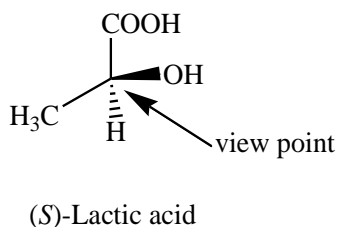
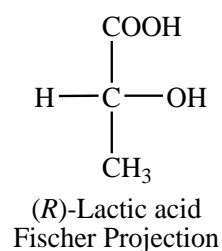
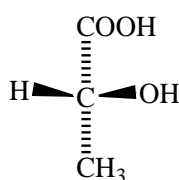
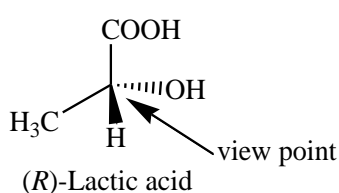

Conversion of flying wedge to Fischer projection formula for Lactic acid

7.10 DIFFERENCE BETWEEN CONFIGURATION AND CONFORMATION

We have used the term conformer to explain isomers related to the rotation about C-C single bond of ethane and butane derivatives, and the term configuration to define some substituted methane and ethylene in the present unit and also in the previous unit (Unit 4). At first glance it seems straightforward to distinguish conformation and configuration. The stereoisomerism which is due to the rotation about a single bond is referred to as conformation. Conformers are easily interconvertible and it is difficult to isolate the isomer. On the other hand, when two compounds are different in their configuration, e.g., a pair of enantiomers of bromofluoromethane, or a pair of geometrical isomers, maleic acid and fumaric acid, these are distinguishable compounds, and their isolation is possible (see section 5.2.3 of this unit).

However, if maleic acid can be converted into fumaric acid by heat, there remains some ambiguity to classify conformational isomers and configurational isomers by their possibility of interconversion. It would be more practical to classify them by their facility of interconversion. A new nomenclature was proposed where stereoisomers with lower energy barrier of conversion are conformers (conformational isomers), while those with higher energy barrier are configurational isomers. If the barrier of interconversion is above 100 kJ mol^{-1} , these are configurational isomer while if it is lower than 100 kJ mol^{-1} , these are conformers. It was previously explained that the rotation about a C=C double bond is restricted by the overlap of p-orbitals, while the rotation about C-C single bond is relatively free. The rotation about a C=C double bond, however, can occur during the reaction; e.g., fumaric acid is converted into maleic acid by heating (see section 5.2.3 of this unit). Thus, the difference between the rotation about a C-C bond and that about a C=C bond might better be regarded as the difference of the required energy to achieve the transition state involved in the rotation.

7.11 SUMMARY

The present unit may be summarized as:

- The stereochemistry, determines many chemical, physical and biochemical properties of the compounds.
- The types of stereo-chemical situations are divided into classes called geometrical isomers, conformational isomers and configurational isomers.
- All of the isomers are studied as a way to understand the shapes and properties of organic compounds.
- Alkenes and cyclic compounds display geometrical isomers.
- In alkenes, geometrical isomers are labeled as *cis*- or *trans*- for the longest chain in the alkene, or as *E* and *Z* for substituents of higher priority attached to the alkene.
- Cyclic alkanes are designated only as *cis*- or *trans*-.
- Rotation around bonds in alkane structures, exemplified in ethane and butane, gives rise to conformational isomers.
- There are an infinite number of conformations for any carbon-carbon single bond, but this book covers only the two extremes: the staggered and eclipsed forms.

- In the staggered form, the torsional angle between attached groups is at 60° . In the eclipsed form, it is at 0° .
- A staggered conformation of ethane or butane has a lower rotational energy than the eclipsed conformation.
- Conformational isomers are drawn with the aid of dotted-line wedge, sawhorse, and Newman projections, and they are analyzed for internal destabilizing steric interactions.
- Wedge-and-dash representations and Newman projections are both ways of visualizing three-dimensional molecules in two dimensions.
- Anti-conformations are usually the more stable with gauche and eclipsed structures of higher energy.
- Analysis of cyclohexane derivatives pays attention to substituents in axial and equatorial positions, with equatorial substituents being more stable.
- The most stable form of cyclohexane is the chair conformation. In this form, the molecule has both axial and equatorial substituents.
- Cyclohexane undergoes a chair-boat-chair ring flip in which the axial substituents become equatorial, and vice versa.
- Interconversions between chair forms involve higher energy structures known as boat, twist and half-chair structures that are unstable.
- Cyclohexanes with axial substituents are less stable than those with the same substituents equatorial, because of unfavorable interactions among axial substituents.

7.12 TERMINAL QUESTION

- Q. 1 Define configurational and conformational isomers.
- Q. 2 Why the geometrical isomers are called diastereomers?
- Q. 3 What is cyclization method for determination of configuration of geometrical isomers?
- Q. 4 How do you determine the configuration of geometrical isomerism using physical method?
- Q. 5 What are staggered and eclipsed conformations of alkanes?

Q. 6 Which conformation of cyclohexane is the most stable and why?

Q. 7 What will be the preferred position for methyl group in the conformation of methyl cyclohexane?

ANSWERS

A.1 The stereoisomerism which is due to the rotation about a single bond is referred to as conformation. Conformers are easily interconvertible and it is difficult to isolate the isomer. On the other hand, when two compounds are different in their configuration, e.g., a pair of enantiomers of bromofluoromethane, or a pair of geometrical isomers, maleic acid and fumaric acid, these are distinguishable compounds, and their isolation is possible

A.2 Geometrical isomers are non-mirror image of each other hence they are called diastereomers. Therefore their physical and chemical properties are different.

A.3 Cyclization method: Cyclization within a molecule (intramolecular) is usually depends upon the distance of two associating groups of a molecule. In other words if the reacting groups are closer to each other than the intramolecular cyclization takes place more effectively. This principal is also helps to identify the configuration of geometrical isomers.

Let us take an example of two geometrical isomer of Butenedioic acid (*i.e.* Maleic acid and Fumaric acid) can be differentiated by possibility of formation of anhydride. Maleic acid which is *cis*- form of Butenedioic acid can only give the respective anhydride on heating; whereas, the *trans*- form of Butenedioic acid (*i.e.* Fumaric acid) does not give its anhydride on heating. If the Fumaric acid is strongly heated it get converted into Maleic acid.

Example : Cyclization of Maleic acid to Maleic anhydride. Fumaric acid does not give the anhydride on heating.

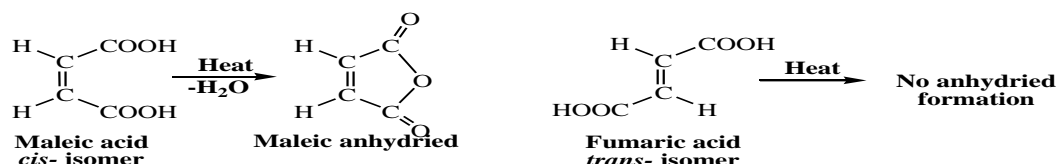

A.4 The geometrical isomers are non-mirror image of each other hence are called diastereomers. We have discussed in Unit 4 that diastereomers have different physical and chemical properties. Based on this fact, we can determine the configuration of geometrical isomers by comparing their physical properties. For example the melting point and absorption intensity of the *cis*-isomer are lower than the *trans*-isomer. Similarly the boiling point,

solubility, heat of hydrogenation, density, refractive index, dipole moment and dissociation constant of *cis*-isomer is greater than the *trans*-isomer.

Thus if you have a set of geometrical isomers, then by comparing their above mentioned physical properties you can assign their configuration (means you can identify the *cis*- and *trans*-isomers).

Example : Diethyl maleate and diethyl fumarate are the *cis*- and *trans*- form to each other. The configuration of these can be determined by comparing their dipole moment. The dipole moment of diethyl maleate is 2.54D whereas the dipole moment of diethyl fumarate is 2.38D. Based on the fact that the dipole moment of *trans*- form of an isomer is lower than that of *cis*-form, you can easily predict the *cis*- and *trans*- form for diethyl maleate and diethyl fumarate.

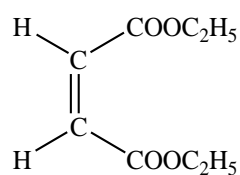

diethyl maleate
dipole moment = 2.54D

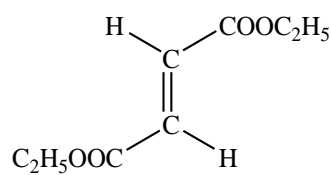

diethyl fumarate
dipole moment = 2.38D

A.5 A conformation with a 60° dihedral angle is known as staggered conformation. The angle between the atoms attached to the front and rear carbon atom is called dihedral angle. A conformation with a 0° dihedral angle is known as eclipsed conformation.

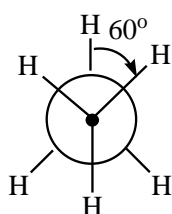

Staggered conformation

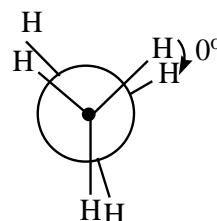

Eclipsed conformation

A.6 The chair conformation is considered as a rigid conformation of cyclohexane in comparison to boat conformation; because during interconversion from chair to boat conformation, some angular deformations are required. These angular deformations usually increase the energy barrier for interconversion from chair to boat conformation. Therefore the chair conformation of cyclohexane is the most stable conformation.

A.7 There are two possible chair conformations for methyl cyclohexane. In one conformation the methyl group located at axial position, whereas in other conformation the methyl group is located at equatorial position. When methyl group is at axial position, it has 1,3-diaxial

interaction with hydrogen atoms at C3 and C5 carbons due to which the energy of such conformation is very high in comparison to the conformer in which the methyl group is at equatorial position. The conformer with methyl group at equatorial position does not have any kind of 1,3-diaxial interaction hence is more stable.

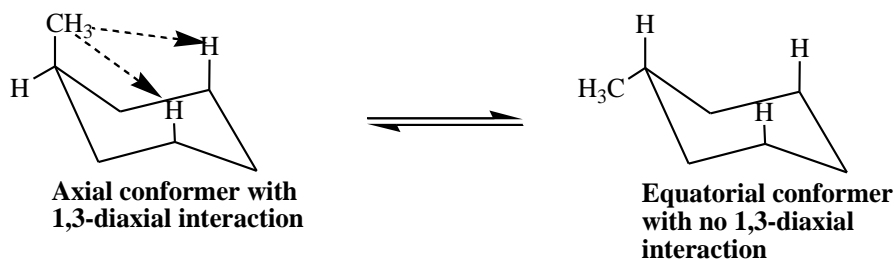

7.13 Bibliography

1. Organic Chemistry Vol. 1 by I L Finar, Published by Pearson Education; ISBN 10: 8177585428.
2. Organic Chemistry by T. W. Graham Solomons, Published by John Wiley; ISBN-10: 1118133579.
3. Stereochemistry of Organic Compounds by Ernest L. Eliel; Published by John Wiley; ISBN- 0-471-01670-5
4. Organic Chemistry by Leroy G. Wade. Published by Pearson Education; ISBN- 9780321768414.

BLOCK III: ALIPHATIC HYDROCARBON

UNIT 8: ALKANE

CONTENTS:

- 8.1 Introduction
- 8.2 Objectives
- 8.3 IUPAC nomenclature of branch and unbranched alkanes
- 8.4 Classification of carbon atoms in alkanes
- 8.5 Isomerism of alkanes
- 8.6 Sources
- 8.7 Methods of formation (with special reactions)
 - 6.7.1 Kolbe's reaction
 - 6.7.2 Corey-House reaction of alkanes.
- 8.8 Mechanism of free radical halogenations of alkanes
 - 6.8.1 Orientation, reactivity and selectivity
- 8.9 Cycloalkanes
 - 8.9.1 Nomenclature
 - 8.9.2 Methods of formation
 - 8.9.3 Chemical reactions
- 8.10 Baeyer's strain theory and its limitations
- 8.11 Summary
- 8.12 Terminal Question
- 8.13 Bibliography

8.1 INTRODUCTION

The alkanes are hydrocarbons that only contain single covalent bonds between their carbon atoms. This means that they are saturated compounds, has no specific reactive functional groups and are quite unreactive. The simplest alkane has only one carbon atom and is called methane. These are saturated hydrocarbons because they have the maximum number of hydrogen atoms. Alkanes are also called Paraffins because of little reactivity towards reagents. Members of a homologous series with general formula C_nH_{2n+2} .

The cycloalkanes are the monocyclic saturated hydrocarbons. In other words, a cycloalkane consists only of hydrogen and carbon atoms arranged in a structure containing a single ring it may contain side chains, and all of the carbon-carbon bonds are single. Cycloalkanes are named like their normal alkane counterparts of the same carbon count: cyclopropane, cyclobutane, cyclopentane, cyclohexane, etc. The larger cycloalkanes, with more than 20 carbon atoms are typically called *cycloparaffins*. In all cycloalkanes carbon of ring are saturated and sp^3 hybridized.

8.2 OBJECTIVE

After completing this unit learners should be able to:

- Learn about hydrocarbon families, IUPAC names, functionally substituted derivatives of alkanes.
- Write the method of preparation of alkane and mechanism of free radical substitution with reference to halogenations.
- Learn about the cyclic hydrocarbon families, IUPAC names, functionally substituted derivatives of cycloalkanes
- Write the methods of formation and chemical reaction of cycloalkane.
- Known Baeyer's strain theory, angle strain, torsional strain, and van der Waals strain.

8.3 IUPAC NOMENCLATURE

The root or parent name for an unbranched alkane is taken directly from the number of carbons in the chain according to a scheme of nomenclature established by the International Union of Pure and Applied Chemistry (IUPAC), as shown below:

Name	Condensed Structure
Methane	CH_4
Ethane	CH_3CH_3
Propane	$CH_3CH_2CH_3$
Butane	$CH_3(CH_2)_2CH_3$
Pentane	$CH_3(CH_2)_3CH_3$
Hexane	$CH_3(CH_2)_4CH_3$
Heptanes	$CH_3(CH_2)_5CH_3$
Octane	$CH_3(CH_2)_6CH_3$
Nonane	$CH_3(CH_2)_7CH_3$
Decane	$CH_3(CH_2)_8CH_3$
Undecane	$CH_3(CH_2)_9CH_3$
Dodecane	$CH_3(CH_2)_{10}CH_3$

The IUPAC rules for naming linear and branched alkanes are given below:

(i) The IUPAC name for an alkane is constructed of two parts:

a) a prefix (meth... eth... prop..., etc.) which indicates the number of carbons in the main, or parent, chain of the molecule, and

b) the suffix **...ane** to indicate that the molecule is an alkane.

(ii) For branched-chain alkanes, the name of the parent hydrocarbon is taken from the **longest continuous chain** of carbon atoms.

(iii) Groups attached to the parent chain are called **substituents** and are named based on the number of carbons in the longest chain of that substituent, and are numbered using the number of the carbon atom on the parent chain to which they are attached. In simple alkanes, substituents are called **alkyl groups** and are named using the prefix for the number of carbons in their main chain and the suffix **...yl**. For example, methyl, ethyl, propyl, dodecyl, etc.

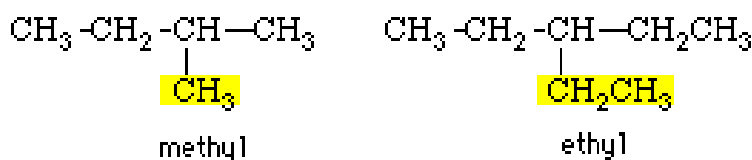

(iv) If the same substituent occurs more than once in a molecule, the number of each carbon of the parent chain where the substituent occurs is given and a multiplier is used to indicate the total number of identical substituents; i.e., **dimethyl... trimethyl... tetraethyl...**, etc.

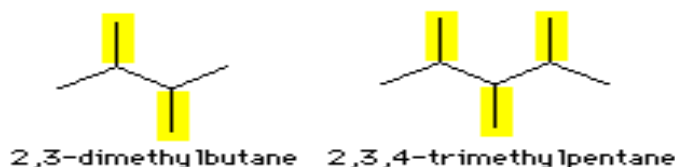

(v) Numbering of the carbons in the parent chain is always done in the direction that gives the lowest number to the substituent which is encountered first, or, the lowest number at the first point of difference. If there are different substituents at equivalent positions on the chain, the substituent of lower alphabetical order is given the lowest number.

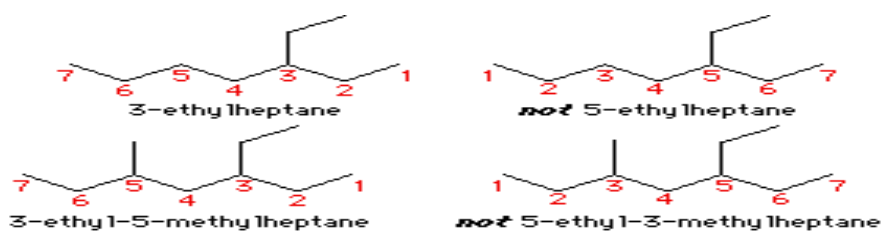

(vi) In constructing the name, substituents are arranged in alphabetical order, without regard for multipliers.

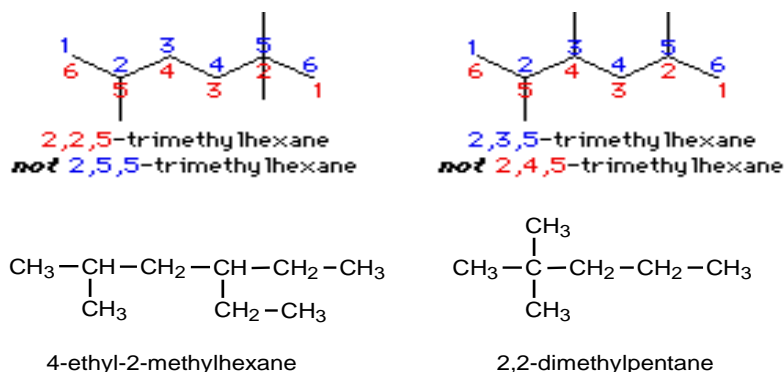

8.4 CLASSIFICATION OF CARBON ATOMS IN ALKANES

By definition, a **primary carbon** is one which is attached to one other or no other carbon atom, a **secondary carbon** is one which is attached to two C- atoms, a **tertiary carbon** is attached to three other C-atoms, and a **quaternary carbon** is attached to four other carbon atoms; these are often abbreviated as 1° , 2° , 3° and 4° carbons.

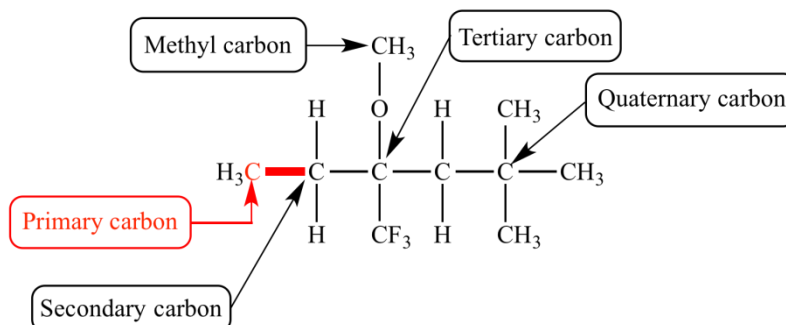

Hydrogens always take the same class as the carbons to which they are bonded. All hydrogens on a *primary* carbon are *primary*. All hydrogens on a *secondary* carbon are *secondary*.

For example $\text{CH}_3\text{CH}_2\text{CH}_3$: Propane contains **two** 1° carbons and one 2° carbon. There are six primary and two secondary hydrogens in propane.

8.5 ISOMERISM OF ALKANES

Different compounds that share the same molecular formula are known as **isomers**. Alkanes exhibit structural isomerism.

- The straight-chain structure and the branched chain structure represent the two isomers of butane, C_4H_{10} .

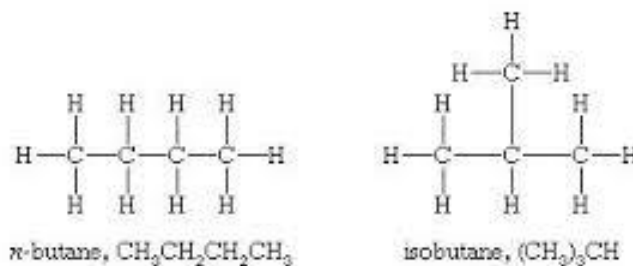

- Isomers of pentane

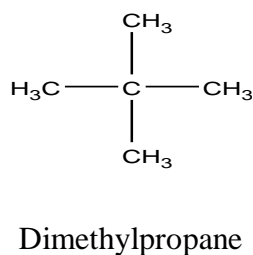
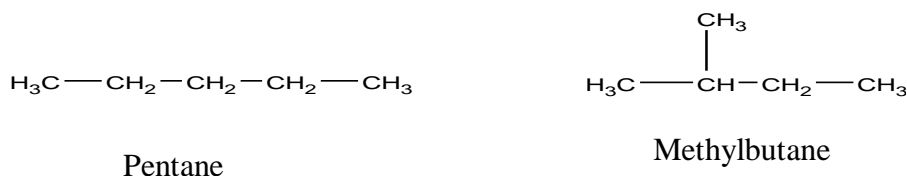

- Isomers of hexane

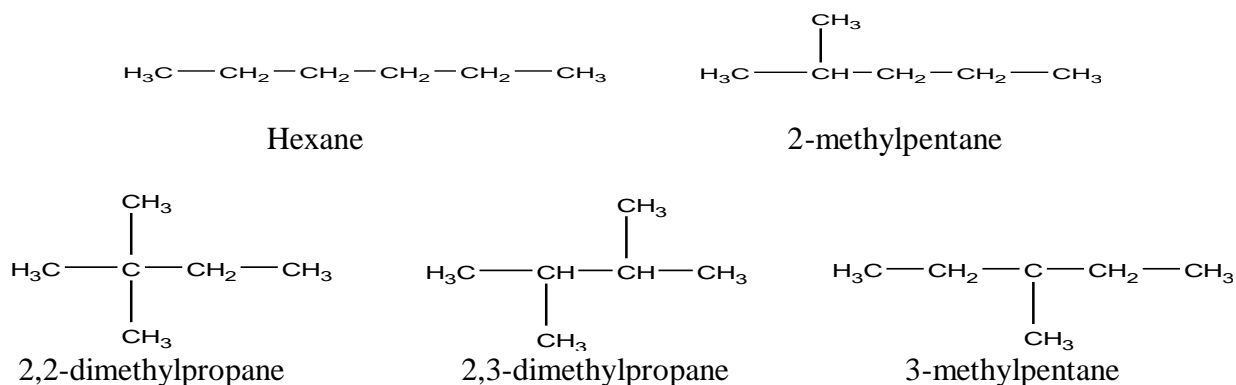

8.6 NATURAL SOURCES

Petroleum and natural gas are the major sources of aliphatic hydrocarbon. The oil trapped inside the rocks is known as petroleum (PETRA – ROCK, OLEUM – OIL). The oil in the petroleum field is covered with a gaseous mixture known as natural gas. The main constituents of the natural gas are methane, ethane, propane and butane. Alkanes are primarily used as energy source through combustion and as raw materials for the chemical industry. The first operation in refining is fractional distillation, which yields different alkane fractions (still complex mixtures of many compounds) based on the volatility of its

components. The high demand for valuable low-molecular-weight alkanes (gasoline) led to the discovery of other refining processes. Valuable industrial methods to prepare many hydrocarbons are the thermal and catalytic crackings (large hydrocarbons are broken into small fragments under the influence of heat and/or catalysts) and catalytic reforming.

8.7 METHODS OF FORMATION

8.7.1 Kolbe's electrolysis method:

Alkanes are formed, on electrolysis of concentrated aqueous solution of sodium or potassium salt of saturated mono carboxylic acids. The electrochemical oxidative decarboxylation of carboxylic acid salts that leads to radicals, which dimerize. It is best applied to the synthesis of symmetrical dimmers.

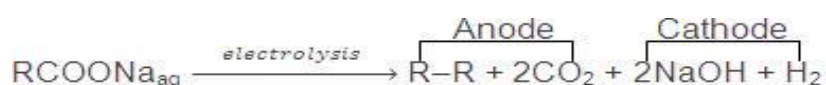

Electrolysis of an acid salt gives symmetrical alkane. However, in case of mixture of carboxylic acid salts, all probable alkanes are formed.



($\text{R}^1\text{-R}^1$ and $\text{R}^2\text{-R}^2$ are also formed).

8.7.2 By Corey-House synthesis:

Alkyl chloride say chloroethane reacts with lithium in presence of ether to give lithium alkyl then reacts with CuI to give lithium dialkyl cuprate. This lithium dialkyl cuprate now again reacts with alkyl chloride to give alkane.

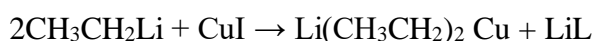

8.7.3 By hydrogenation of alkenes: Sabatier and senderen's method:

(a) Alkenes and alkynes on catalytic hydrogenation give alkanes. Catalyst Ni is used in finely divided form.

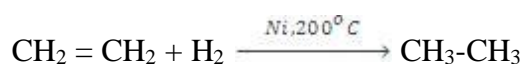

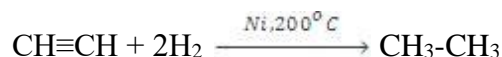

8.7.4 Wurtz reaction:

A solution of alkyl halide in ether on heating with sodium gives alkane.



An alkyl halide on Wurtz reaction leads to the formation of symmetrical alkane having an even number of carbon atoms. Two different alkyl halides, on Wurtz reaction give all possible alkanes.



8.7.5 By Reduction of Carbonyl compounds:

The reduction of carbonyl compounds by amalgamated zinc and conc. HCl also yields alkanes. This is Clemmensen reduction.

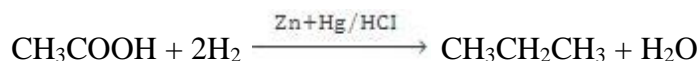
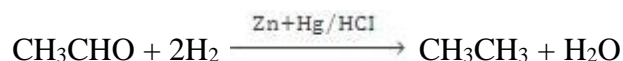

Carbonyl compounds may also be reduced to alkanes by Wolf Kishner reaction

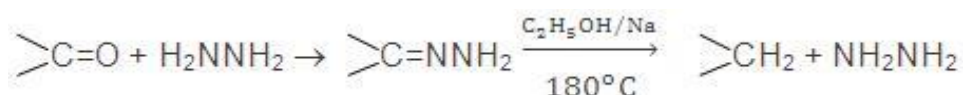

8.8 HALOGENATION OF ALKANE

Halogenation is a substitution reaction of one or more hydrogen atoms in an organic compound by a halogen (fluorine, chlorine, bromine or iodine). This reaction is a photochemical one. The products of this reaction are an alkyl halide or haloalkane and a hydrogen halide.

Alkanes are not very reactive molecules. However, alkyl halides are very useful reactants for the synthesis of other organic compounds. Thus, the halogenation reaction is of great value because it converts uncreative alkanes into versatile starting materials for the synthesis of desired compounds. This is important in the pharmaceutical industry for the synthesis of some drugs. In addition, alkyl halides having two or more halogen atoms are useful solvents, refrigerants, insecticides, and herbicides.

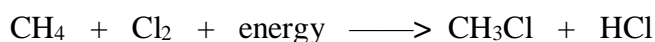

The reaction does not necessarily stop at one substitution, and the reaction between methane and chlorine produces dichloro-, trichloro- and tetrachloro- methane.

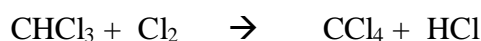
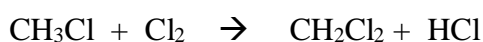
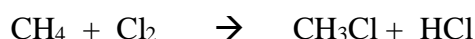

The process of substitution is random, so all possible products result, though if there is excess methane the main one will be CH_3Cl , while a large excess of chlorine will give mainly CCl_4 .

Mechanisms:

The substitution of a hydrogen atom by a chlorine atom actually takes place in a number of stages. Halogenation of an alkane takes place by a **free radical** reaction. The reaction between alkanes and these halogens requires an energy source such as ultra violet (u.v.) light. Typically, free radical reactions are described in three steps: initiation steps, propagation steps, and termination steps.

Initiation step: The photochemical energy is used to split the chlorine molecule to form two chlorine free radicals; the chlorine free radicals have an unpaired electron – such a species is called **free radical**. Single headed arrows are used during the movement of a single electron. This is called the **initiation step**.

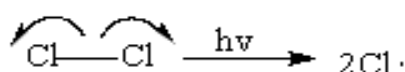

Free radicals are very reactive as they are trying to pair up their unpaired electron. If there is sufficient chlorine, every hydrogen will eventually be replaced.

Propagation Steps:

The chlorine radical then attacks the methane molecule.

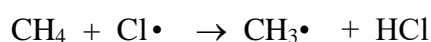

The methyl radical from this reaction reacts with a chlorine molecule to form chloromethane and new chlorine radical.

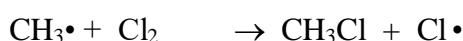

The chlorine radical starts the cycle again and the process continues. In the propagation stage the $\text{Cl}\cdot$ at the end can go on to attack another CH_4 and so the chain can go on for several thousand reactions from one initiation. These two reactions are called the **propagation stage**. The propagation stage continues until two radical meet to form a molecule.

Termination Steps:

There are three possibilities for this reaction. Since the ends the sequence it is called the **termination stage**. In this step free radicals are meet to form a molecule.

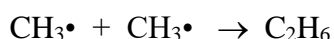
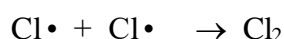

The overall mechanism is called **free radical substitution**. The presence of traces of C_2H_6 in the products shows that $\text{CH}_3\cdot$ radicals must have been formed. Of course, the $\text{Cl}\cdot$ atoms can remove a hydrogen atom from CH_3Cl , and so the reaction can go on to CH_2Cl_2 , then CHCl_3 and finally CCl_4 .

mechanism for the monochlorination of methane

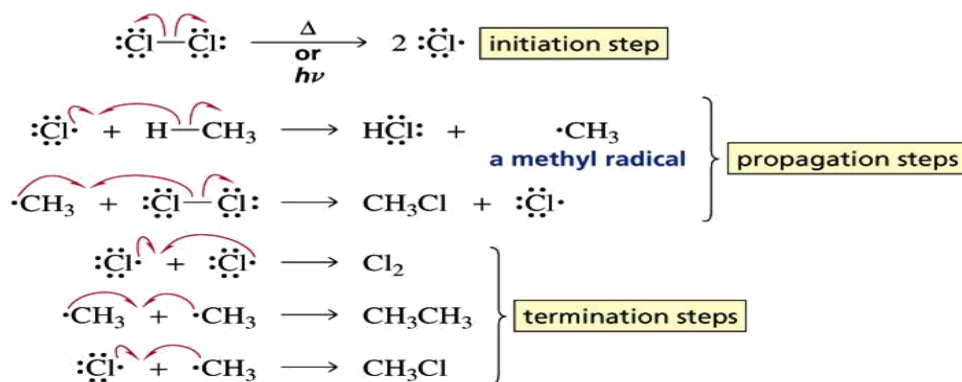

The following facts must be accommodated by any reasonable mechanism for the halogenation reaction.

- (i) The reactivity of the halogens decreases in the following order: $\text{F}_2 > \text{Cl}_2 > \text{Br}_2 > \text{I}_2$.
- (ii) Chlorinations and brominations are normally exothermic. Fluorination is so explosively reactive it is difficult to control, and iodine is generally unreactive.

- (iii) Energy input in the form of heat or light is necessary to initiate these halogenations.
- (iv) If light is used to initiate halogenation, thousands of molecules react for each photon of light absorbed.
- (v) Halogenation reactions may be conducted in either the gaseous or liquid phase.
- (vi) In gas phase chlorinations the presence of oxygen (a radical trap) inhibits the reaction.
- (vii) In liquid phase halogenations radical initiators such as peroxides facilitate the reaction.

8.8.1 Orientation, reactivity and Selectivity:

When alkanes larger than ethane are halogenated, isomeric products are formed. All the hydrogens in a complex alkane do not exhibit equal reactivity. Hydrogens attached to more highly substituted carbons (ie. carbons with many carbons attached to them) are more reactive in free-radical halogenation reactions because the radical they form is stabilized by neighboring alkyl groups. These neighboring alkyl groups have the ability to donate some of their electron density to the electron-deficient radical carbon (a radical is short one electron of filling the atom's valence octet).

For example, propane has eight hydrogens, six of them being structurally equivalent **primary**, and the other two being **secondary**. If all these hydrogen atoms were equally reactive, halogenation should give a 3:1 ratio of 1-halopropane to 2-halopropane mono-halogenated products, reflecting the primary/secondary numbers. This is not what we observe. Light-induced gas phase chlorination at 25 °C gives 45% 1-chloropropane and 55% 2-chloropropane.

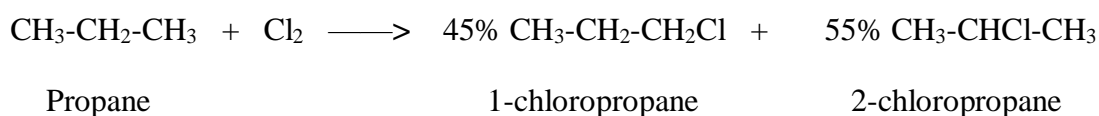

The results of bromination (light-induced at 25 °C) are even more surprising, with 2-bromopropane accounting for 97% of the mono-bromo product.

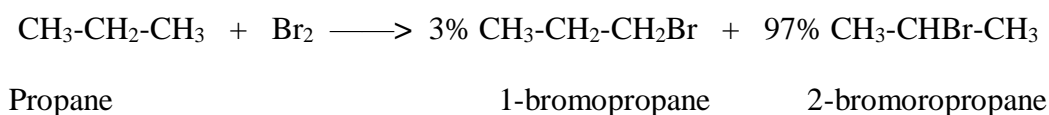

These results suggest strongly that 2°-hydrogens are inherently more reactive than 1°-hydrogens, by a factor of about 3:1. 3°-hydrogens are even more reactive toward halogen atoms. Thus, light-induced chlorination of 2-methylpropane gave predominantly (65%) 2-chloro-2-methylpropane, the substitution product of the sole 3°-hydrogen, despite the presence of nine 1°-hydrogens in the molecule.

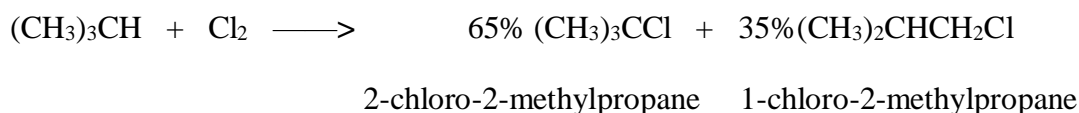

In the above reaction hydrogen on the tertiary carbon is abstracted in preference to the 9 other hydrogen atoms attached to a primary carbon (a carbon that is attached to only one other carbon atom) because it forms a more stable radical.

It should be clear from the above reactions that the hydrogen abstraction from alkane by a free radical is the product determining step. Once a carbon radical is formed, subsequent bonding to a halogen atom (in the second step) can only occur at the radical site. Consequently, an understanding of the preference for substitution at 2° and 3°-carbon atoms must come from an analysis of this first step.

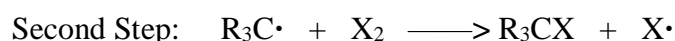
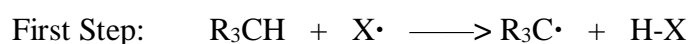

Since the H-X product is common to all possible reactions, differences in reactivity can only be attributed to differences in C-H bond dissociation energies. Product distributions are governed by the number and relative reactivities of hydrogens, and the reactivities of the reactants.

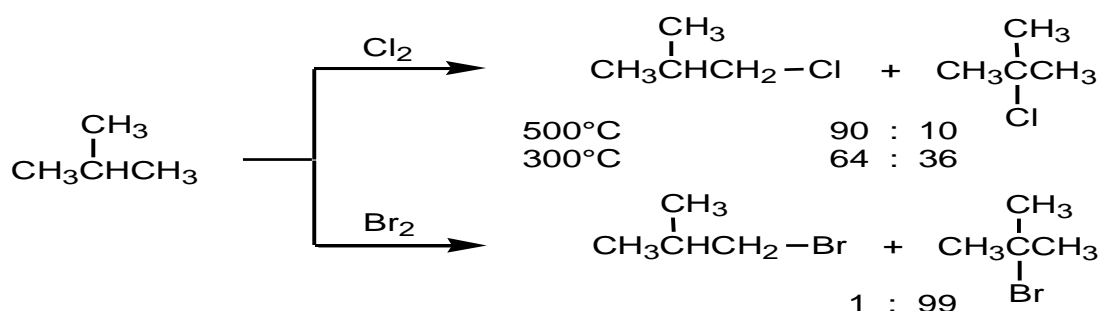

There is an activation energy difference between the formation of primary and secondary radicals; therefore, the latter is more abundant. Furthermore, bromination is more selective than chlorination because of the much lower reactivity of the bromine radical.

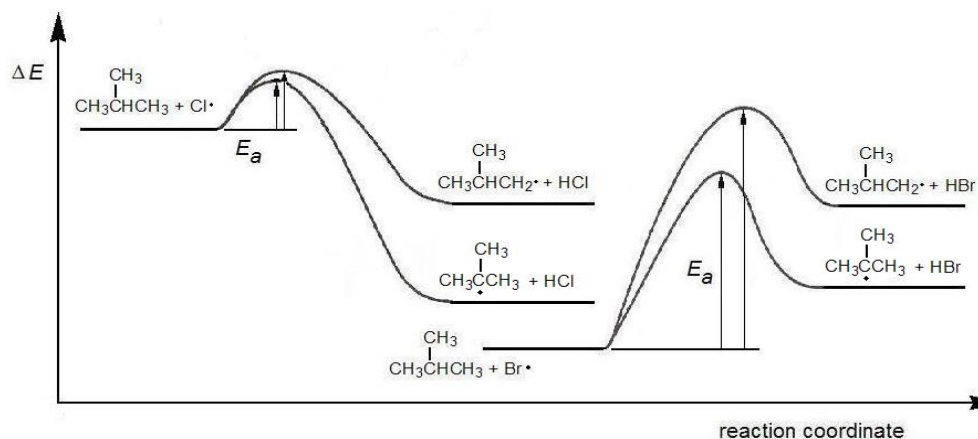
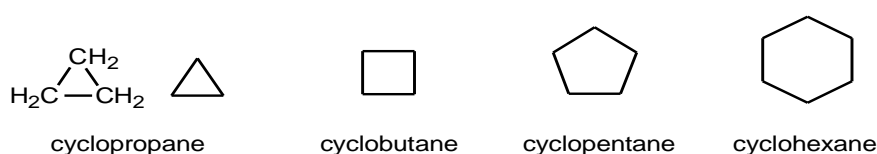

Figure 8.1. Energy changes occurring during the formation of primary and secondary radicals in free-radical chlorination and bromination of isobutane.

8.9 CYCLOALKANE

For a simple cycloalkane the general molecular formula is C_nH_{2n} , where n is the total number of carbons. This formula differs from the general formula for an alkane (C_nH_{2n+2}) by the lack of the two additional hydrogens (the "+ 2 term"). As a general rule, every ring which is constructed from an alkane reduces the number of hydrogens in the molecular formula for the parent hydrocarbon by two.

You should note that, in the smaller ring sizes (3, 4 and 5), the bond angles are significantly less than the tetrahedral angle 109.5° . This results in a significant amount of ring strain in these compounds which make many small rings susceptible to ring-opening reactions. The bond angles in a six-membered ring match well with the tetrahedral geometry of carbon and there is virtually no ring strain in these compounds. Rings which are seven-membered and larger are highly distorted, and again display significant ring strain.



8.9.1 Nomenclature:

The nomenclature for a simple cycloalkane is based on the parent hydrocarbon, with the simple addition of the prefix **cyclo**. A three-membered ring is therefore cyclopropane, four-membered, cyclobutane, five-membered, cyclopentane, six-membered, cyclohexane, etc.

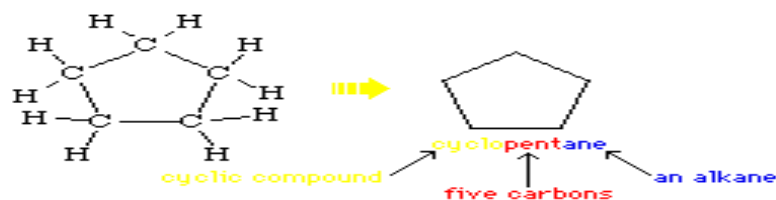

As a convenient shortcut, cyclic structures are usually drawn using line (structural or line-angle) drawings, as shown above. Again, it is important to understand that every vertex in these drawings represents a $-\text{CH}_2-$ group, every truncated line a $-\text{CH}_3$ group and intersections of three or four lines represent 3° or 4° carbons, respectively. Substituents on cycloalkanes are named using the conventions described for alkanes, with the exception that, on rings bearing only one substituent, no number is needed. Substituted cycloalkanes are named as alkylcycloalkanes. When more than one substituents are present, number the ring beginning with one substituent in the way that gives the next substituent the lowest number possible.

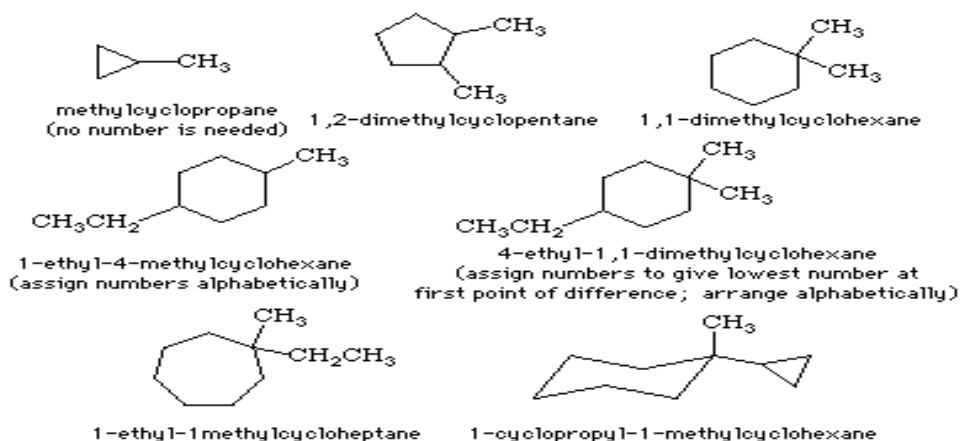

8.9.2 Preparation of cycloalkanes:

(i) **By Perkin's Method:** In this method vicinal dihalide reacts with diester of dicarboxylic acid followed by hydrolysis and heated form cycloalkane.

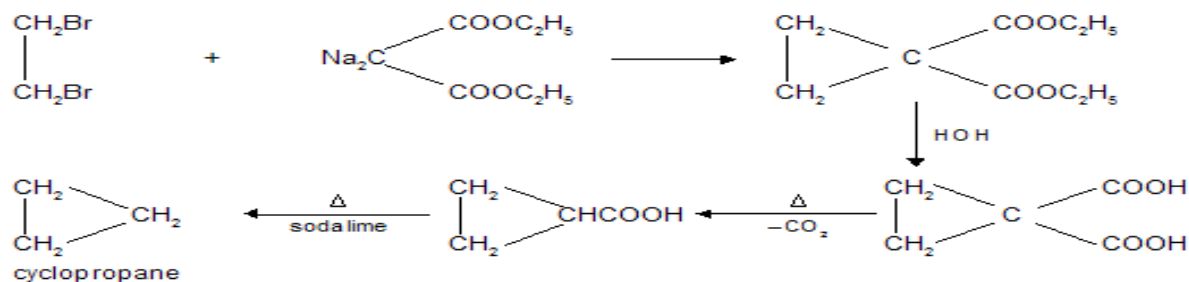

(ii) **By pyrolysis of divalent metal salts of dicarboxylic acids (Wislicenus method):** In this method salts of dicarboxylic acids heated followed by reduced with $\text{Zn}/\text{Hg}-\text{HCl}$ form cycloalkane.

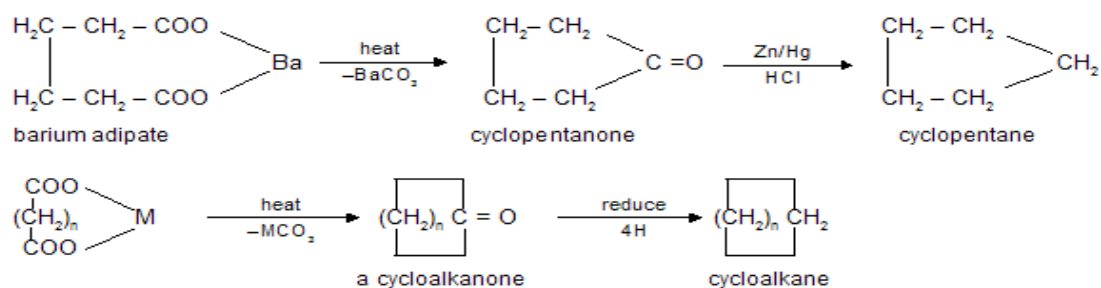

(iii) By Freund reaction: Elimination of terminal halogen atoms from dihalides with Na or Zn dust gives rise to the formation of cycloalkanes. The method can also be regarded as intramolecular Wurtz reaction. This can be used to prepare cycloalkanes from three to six carbon atoms.

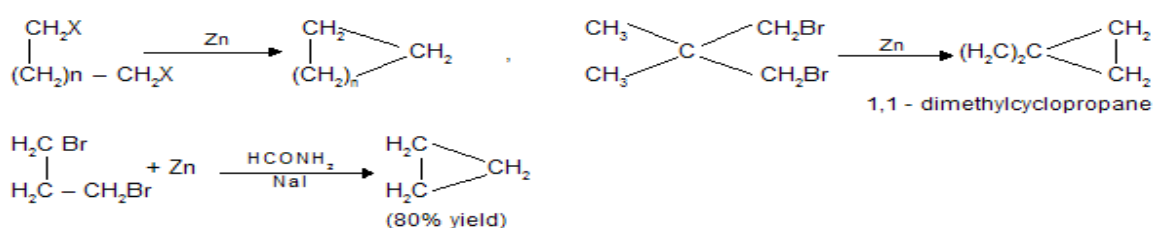

(iv) By the use of carbenes: Carbenes are unstable intermediates in which carbon has pair of unshared electrons. These are neutral species and have no formal charge, $:\text{CH}_2$ (methylene) is the simplest member of this series. On account of greater stability di halo carbenes ($:\text{CX}_2$) are also used. Carbenes are easily prepared in solution as shown below and in the same form they are used for the reaction. This method is very useful for the preparation of small ring compounds.

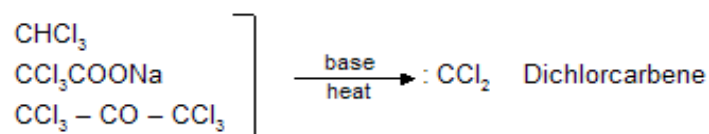

Methylene is prepared as follows

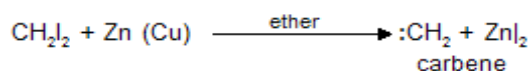

Cyclopropane and its derivatives can easily be prepared by the use of carbenes.

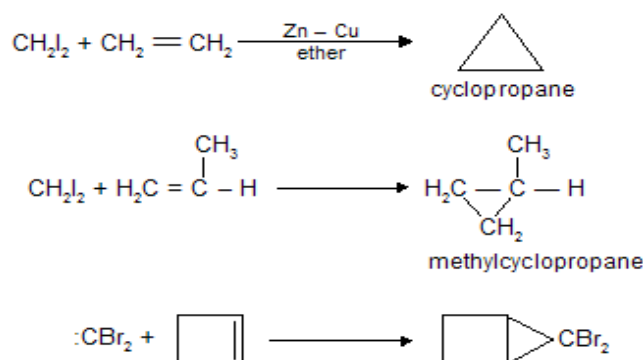

(v) **Reduction of a cyclic ketone:** The Wolff-Kishner carbonyl reduction is a good method for converting carbonyl group directly to methylene group. It involves heating the hydrazone of carbonyl compound in the presence of an alkali and a metal catalyst.

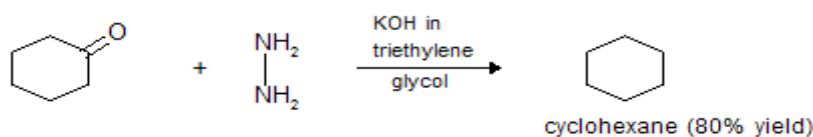

The Clemmensen's and Wolff- Kishner carbonyl reductions complement each other, for the former is carried out in acid solution, and the latter in alkaline solution. Thus, the Clemmensen carbonyl reduction may be used for alkali-sensitive compounds whereas Wolff-Kishner carbonyl reduction is the method of choice with acid sensitive compounds.

vi) **From aromatic compounds:** Six membered cyclo compounds can be easily obtained by the catalytic reduction of benzene and its derivatives.

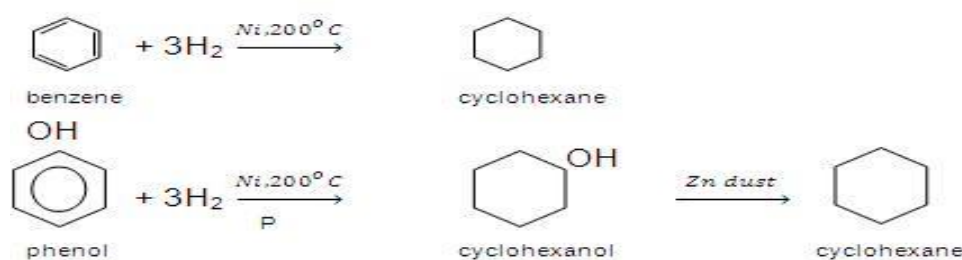

8.9.3 Chemical reactions:

Cycloalkanes are relatively inert towards the action of common reagents at room temperature. But cyclopropane and cyclobutane are exceptions and show a tendency to react with opening of the ring. Cyclopropane forms addition products with ring fission, as show:

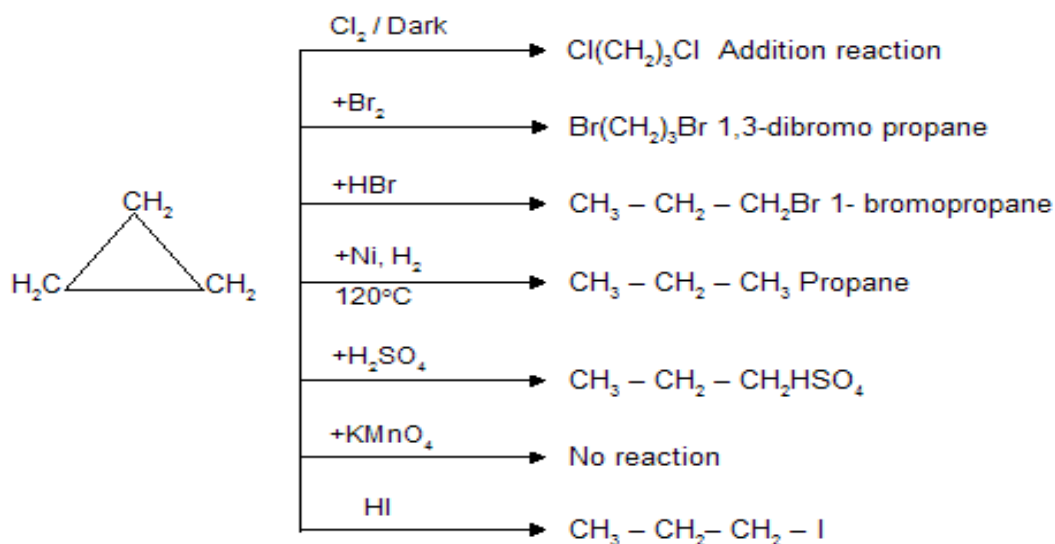

All other cycloalkanes show the reactivity expected by alkanes, i.e. they react by substitution. In diffused light, cyclopropane reacts with chlorine to give substitution product.

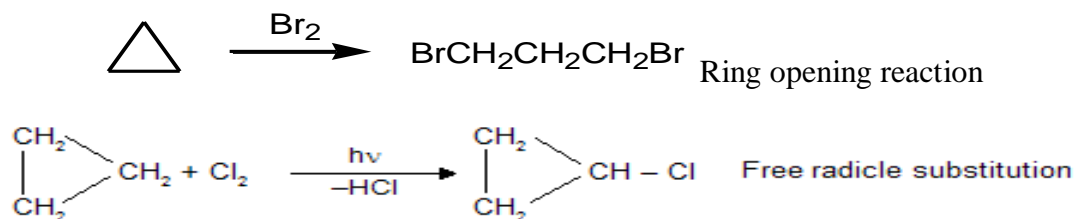

Oxidation: Cycloalkanes are oxidized by alkaline potassium permanganate to dicarboxylic acids involving ring fusion.

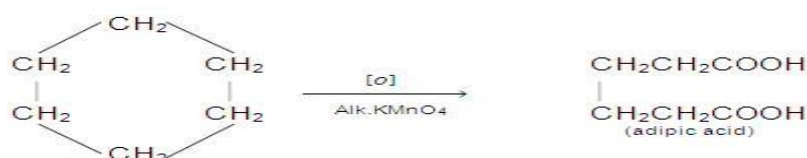

8.10 STABILITY OF CYCLOALKANE; BAEYER STRAIN THEORY

Adolf Van Baeyer, a German chemist, in 1885, proposed a theory to explain the relative stability of cycloalkanes. The theory is based on the fundamental concept of regular tetrahedral structure as given by Vant Hoff and Le Bel. According to them “the tetravalency of carbon atom are directed towards the four corners of a regular tetrahedron with carbon atom at the centre making an angle of $109^{\circ}28'$ between any pair of such valencies.” He argued that because the bond angles of small rings (60° for cyclopropane and 90° for cyclobutane) are significantly lower than the tetrahedral angle (109.5°), the rings suffer from strain (angle strain) and so are highly reactive, readily undergoing strain-relieving ring opening reactions. Baeyer’s arguments for larger alicyclic were that, beyond cyclopentane and cyclohexane, the bond angles became significantly higher than the tetrahedral angle, leading to the opposite kind of ring strain and instability. This argument was erroneous, especially for the larger rings, because Baeyer assumed planar structures. In reality, only cyclopropane is truly planar, the rest having puckered structures. Despite this error, Baeyer’s ideas on angle strain are still very useful.

Strain $\beta = \frac{1}{2}(109^{\circ}28' - \text{bond angle})$ where all the carbon atoms in the ring are in the same plane. Suppose there are n carbon atoms in the ring, then the bond angle of ring would be

$$\frac{n \times 180^\circ - 360^\circ}{n} = \frac{180^\circ (n - 2)}{n}$$

The amount of strain (δ) in the various cycloalkanes would be as :

$$\text{cyclopropane } \beta = \frac{1}{2} (109^\circ 28' - 60^\circ) = 24^\circ 44'$$

$$\text{cyclobutane } \beta = \frac{1}{2} (100^\circ 28' - 90^\circ) = 9^\circ 44'$$

$$\text{cyclopentane } \beta = \frac{1}{2} (109^\circ 28' - 108^\circ) = 0^\circ 44'$$

$$\text{cyclohexane } \beta = \frac{1}{2} (109^\circ 28' - 120^\circ) = -5^\circ 16'$$

$$\text{cycloheptane } \beta = \frac{1}{2} (109^\circ 28' - 128.5^\circ) = -9^\circ 33'$$

$$\text{cyclo octane } \beta = \frac{1}{2} (109^\circ 28' - 135^\circ) = -12^\circ 46'$$

It can be seen from the above data that the lowest value of the deviation is found in five and six-membered rings and so cyclopentane and cyclohexane are the most stable systems. The negative value of angle strain indicates that the bonds are bent outwards. The Baeyer's strain theory could easily explain the greater reactivity of cyclopropane and cyclobutane and the stability of cyclopentane and cyclohexane rings.

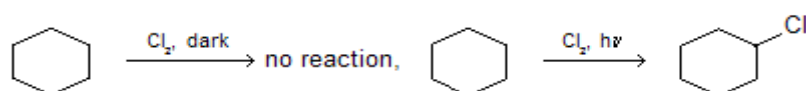

In above example cyclohexane is stable ring, so it cannot react in dark but in the presence of sunlight free radical substitution reaction occurs

Heats of Combustion and Relative Stabilities of Cycloalkanes

Stability, according to heats of combustion, reaches a maximum at cyclohexane and then decreases slightly until the ring size reaches 17, as shown in the table below.

Ring size	Heat of combustion per CH ₂ /kJ mol ⁻¹
3	696.4
4	685.5
5	663.4
6	657.9
7	661.7
8	662.9
12	658.8
17	657.1

The heat of combustion per CH₂ for alkanes is 657.9 kJ mol⁻¹.

From the above data, it is possible to calculate ring strain energy by subtracting the value $657.9 \text{ kJ mol}^{-1}$ from the figures in the table and multiplying by the number of CH_2 units in the rings. It can be seen that cyclopropane and cyclobutane are indeed strained, but cyclopentane is more strained than predicted by Baeyer's theory and for larger rings, there is no regular increase in strain. Furthermore, rings of more than 14 carbon atoms are actually strain-free.

The Nature of Ring Strain

The complex picture presented above can be explained only by supposing that cycloalkane minimum-energy conformations result from the balancing of three kinds of strain:

Angle strain: It is the strain induced in a molecule when the bond angles are different from the ideal tetrahedral bond angle of 109.5° , i.e., the strain caused by distortion of bond angles.

Torsional strain – it is caused by repulsion between the bonding electrons of one substituent and the bonding electrons of a nearby substituent, i.e., the strain caused by eclipsing of bonds on adjacent atoms.

Steric strain – the strain caused by repulsive interactions when nonbonding atoms are too close to each other, i.e., it is caused by atoms or groups of atoms approaching each other too closely.

Cyclopropane and cyclobutane, with ring angles of 60° and 90° respectively, suffer from the most angle strain and even the two main conformers of cyclopentane have a small amount of angle strain. Apart from angle strain, the single planar conformer of cyclopropane has eclipsed C-H bonds, with maximum torsional strain:

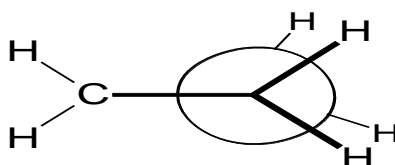

The larger rings can minimize torsional strain by adopting puckered (nonplanar) conformations.

Cyclopropane: an Orbital Picture of Ring Strain

In normal saturated compounds, the carbon atoms are sp^3 -hybridized, with C-C-C and H-C-H bond angles close to 109.5° . Overlap between the atomic orbitals involved in these bonds is a maximum.

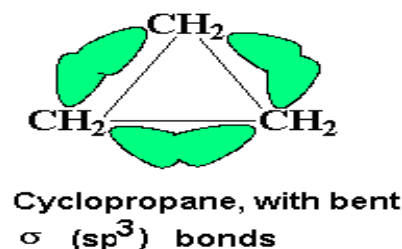
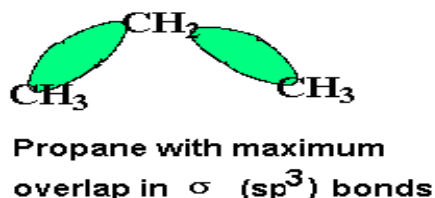

In cyclopropane, the C-C-C bond angle cannot be 109.5° , so there is poor overlap making the C-C bonds weaker than in open chain equivalents.

The Conformations of Cyclobutane and Cyclopentane

Like cyclopropane, the planar conformation of cyclobutane has considerable bond strain and torsional strain and hence the more favorable conformer of cyclobutane is puckered, with one carbon atom laying some 25° out of the plane formed by the other three carbon atoms. This conformer has rather more angle strain but considerably less torsional strain, because the C-H bonds are not fully eclipsed.

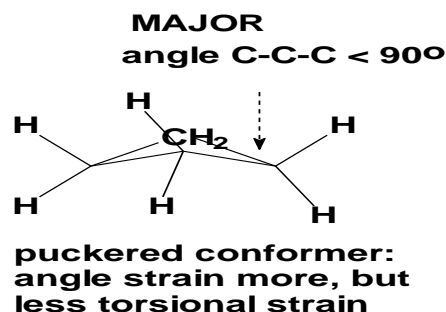
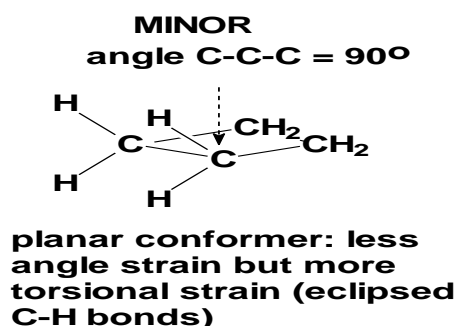

A similar, but more complex situation arises in cyclopentane, the two puckered forms being (about equally) more favorable than the planar conformer. Generally cyclic alkanes found in nature have five or six-membered rings. On the other hand, compounds with three and four-membered rings are found much less frequently. This observation suggested that alkanes with five- and six-membered rings must be more stable than those with three- or four-membered rings. It was proposed that such instability could be explained on the bases of angle strain. Ideally, a sp^3 hybridized carbon has bond angles of 109.5° . As a result, stability of a cycloalkane may be predicted by determining how close the bond angle of a planar cycloalkane is to 109.5° . The angles of an equilateral triangle are 60° . Therefore, the bond angles in a planar cyclopropane are compressed from the ideal bond angle of 109.5° to 60° , a 49.5° deviation causing angle strain. As described earlier, normal sigma bond between two carbon atoms are formed by the overlap of two sp^3 orbitals that point directly at each other. In

cyclopropane, overlapping orbitals cannot point directly at each other. Therefore, the orbital overlap is less effective than in a normal C-C bond. Hence, the less effective orbital overlap causes the C-C bond to be weaker and could be easily broken i.e. reactive.

For example, cyclopropane could be readily hydrogenated to propane. Because the C-C bonding orbitals in cyclopropane cannot point directly at each other, they have shapes that resemble bananas and, consequently, are often called **banana bonds**. In addition to angle strain, three-membered rings have torsional strain as a result of the fact that all hydrogen atoms are eclipsed.

Similarly, the bond angles in planar cyclobutane would have to be compressed from 109.5° to 90° , the bond angle associated with a planar square. Planar cyclobutane would then be expected to have fewer angles strain than cyclopropane because the bond angles in cyclobutane are only 19.5° away from the ideal angle.

Considering angle strain as the only factor, it was predicted that cyclopentane be the most stable of cycloalkanes because its bond angles (108°) are closest to the ideal tetrahedral one. In addition, it may be predicted that cyclohexane, with bond angles of 120° , would be less stable.

Cycloalkane	Strain Energy (kJ/mol)
Cyclobutane	110.9
Cyclopropane	114.2

In contrast to smaller rings, distortion from planarity in cyclohexane relieves both the angle and torsional strain of the planar structure. Once more, the internal angle in a planar hexagon is 120° , larger, not smaller, than the ideal sp^3 angle. Deviation from planarity will decrease both this angle and torsional strain from the six pairs of eclipsed hydrogens in planar model. This energy minimum cyclohexane is called the chair form. In the chair conformer of cyclohexane, all bond angles are 111° and all the adjacent bonds are staggered. Equatorial carbon-hydrogen bonds are parallel to the ring carbon-carbon bonds one bond away in chair cyclohexane. Axial carbon-hydrogen bonds are parallel and pointing either straight up or down in chair cyclohexane.

Equatorial carbon-hydrogen bonds are parallel to the ring carbon-carbon bonds one bond away in chair cyclohexane. Axial carbon-hydrogen bonds are parallel and pointing either straight up or down in chair cyclohexane. Cyclohexane rapidly interconverts between two

stable chair conformations because of the ease of rotation about its C-C bonds. Such process is called ring flip. When the chair form interconvert, bonds that are equatorial in one chair conformer become axial in the other chair conformer and vice versa. Cyclohexane can also exist in a boat conformation similar to the chair conformer; the boat conformer is free of angle strain. However, the boat conformer is not as stable because some of its bonds are eclipsed, giving torsional strain to the molecule. In addition, the boat conformation is further destabilized by the close proximity of the “flagpole hydrogens” which causes steric strain.

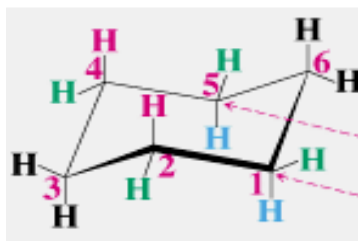

Cyclohexane conformations:

Cyclohexane is one of the most important. If the carbons of a cyclohexane ring were placed at the corners of a regular planar hexagon, all the C-C-C bond angles would have to be 120° . Because the expected normal C-C-C bond angle should be near the tetrahedral value of 109.5° , the suggested planar configuration of cyclohexane would have angle strain at each of the carbons, and would correspond to less stable cyclohexane molecules than those with more normal bond angles. The actual normal value for the C-C-C bond angle of an open-chain — $\text{CH}_2\text{—CH}_2\text{—CH}_2\text{—}$ unit appears to be about 112.5° , which is 3° greater than the tetrahedral value. From this we can conclude that the angle strain at each carbon of a planar cyclohexane would be $(120^\circ - 112.5^\circ) = 1.5^\circ$. Angle strain is not the whole story with regard to the instability of the planar form, because in addition to having C-C-C bond angles different from their normal values, the planar structure also has its carbons and hydrogens in the unfavorable eclipsed arrangement, as shown in following figure.

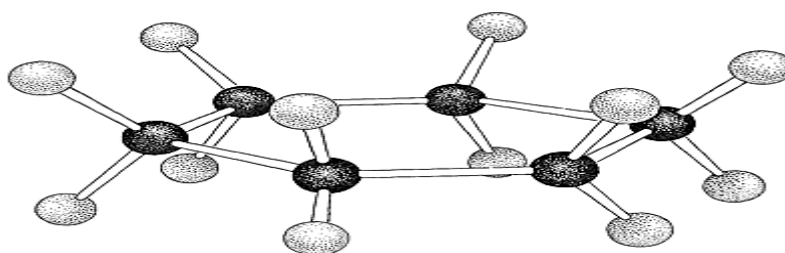
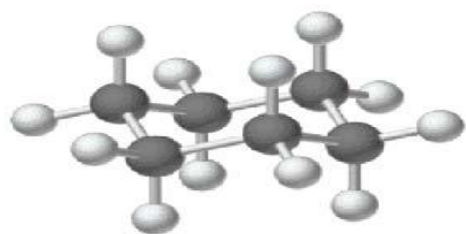
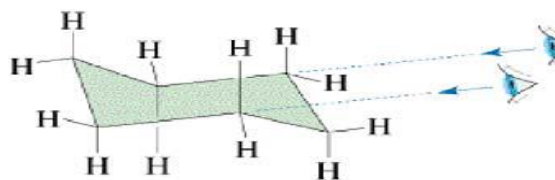

Figure 8.2: Cyclohexane in the strained planar configuration showing how the hydrogens become eclipsed



chair conformation of cyclohexane



chair conformation

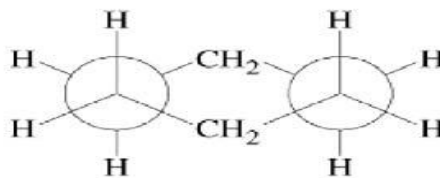

Newman projection

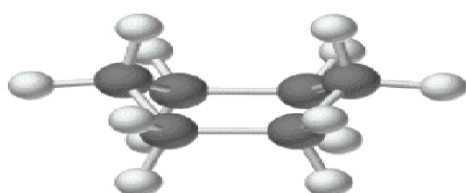

boat conformation of cyclohexane

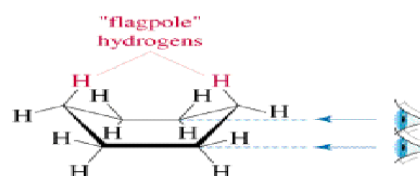

symmetrical boat

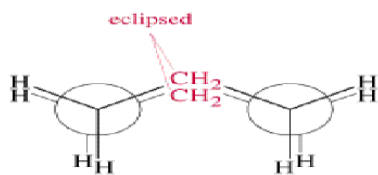

Newman projection

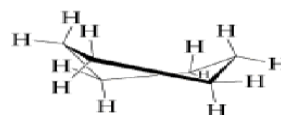

"twist" boat

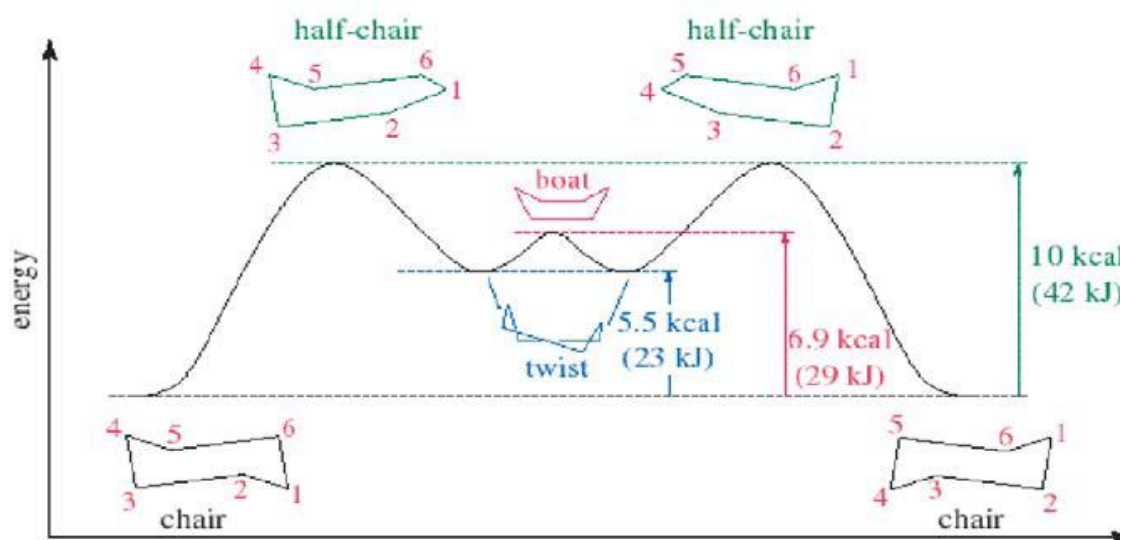

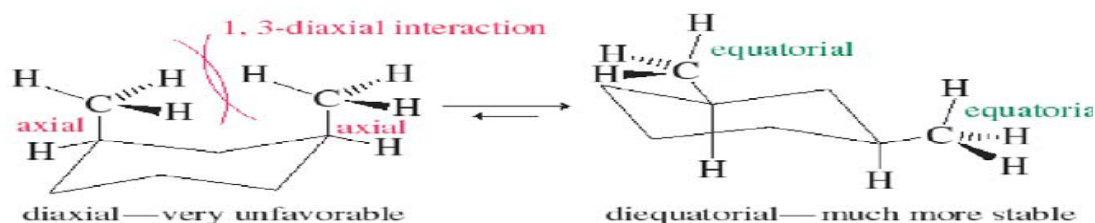

Therefore the chair form is expected to be more stable than the boat form because it has less repulsion between the hydrogens.

8.11 SUMMARY

- Classification of carbon atom of alkane and systematic IUPAC nomenclature of alkane and cycloalkane.
- Name reaction involved in the chemical reactions of alkanes such as wurtz reaction, clemmensen reduction and Wolf Kishner reaction.
- Orientation, reactivity and Selectivity involved in the chemical reactions of heiger alkanes.
- By using Wislicenus method, Perkin's Method and Freund reaction cycloalkane can be prepared.
- Baeyer strain theory explain the Stability of cycloalkane.

8.12 TERMINAL QUESTION

Q.1 Name the following alkyl halides according to IUPAC rules.

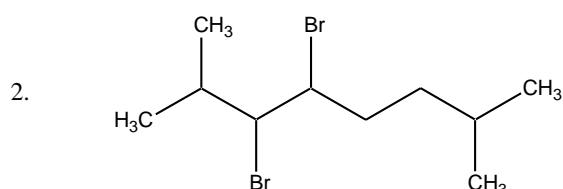
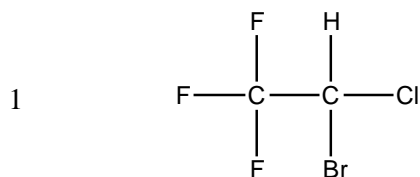

Q.2 Draw structures corresponding to the following IUPAC names.

(a) 2-chloro-3,3- diethylhexane (b) 4- sec-butyl-2-chlorononan

Q.3 Draw out and name the structural isomers of C_5H_{12} and C_6H_{14} .

Q.4 Complete the following reaction:

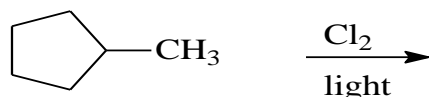

Q.5 Which of the following is the key intermediate in the chlorination reaction below?

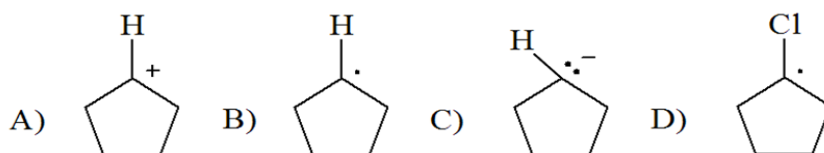

Q.6 Discuss the conformations of cyclohexane.

Q.7 Discuss the methods of preparation of alkane and their chemical properties.

8.13 BIBLIOGRAPHY

1. Organic Chemistry Vol. 1 by I L Finar, Published by Pearson Education; ISBN 10: 8177585428.
2. Organic Chemistry by T. W. Graham Solomons, Published by John Wiley; ISBN-10: 1118133579.
3. Stereochemistry of Organic Compounds by Ernest L. Eliel; Published by John Wiley; ISBN- 0-471-01670-5
4. Organic Chemistry by Leroy G. Wade. Published by Pearson Education; ISBN- 9780321768414.

UNIT 9: ALKENE

CONTENTS:

- 9.1 Introduction
- 9.2 Objectives
- 9.3 Nomenclature of alkenes
- 9.4 Isomerism of alkenes
- 9.5 Methods of preparation
- 9.6 Physical properties of alkenes
- 9.7 Chemical reaction of alkenes
 - 9.7.1 Mechanism involved in hydrogenation
 - 9.7.2 Electrophilic and free radical addition
 - 9.7.3 Markownikoff's rule
 - 9.7.4 Hydroboration oxidation
 - 9.7.5 Oxymercuration reduction
 - 9.7.6 Ozonolysis
 - 9.7.7 Oxidation with KMnO_4 and OsO_4
 - 9.7.8 Polymerization of alkenes
- 9.8 Industrial application of ethylene and propene
- 9.9 Diene
- 9.10 Nomenclature and classification of dienes
- 9.11 Isolated, conjugated and cumulated dienes
- 9.12 Structure of allenes and butadienes
- 9.13 Methods of formation
- 9.14 Polymerization.
- 9.15 Chemical reactions
- 9.16 Summary
- 9.17 Terminal question
- 9.18 Bibliography

9.1 INTRODUCTION

An alkene in organic chemistry is an unsaturated acyclic hydrocarbon containing at least one carbon to carbon double bond. The simplest alkenes, with only one double bond, form a

homologous series, *the alkenes* with general formula C_nH_{2n} . A double bond is a σ bond and a π bond. A π bond is weaker than a σ bond and hence more reactive than σ bonds. Due to this, π bonds are considered to be a functional group. Alkenes are also called olefins (from Greek: ‘oil-formers’) and vinyl compounds. Terminal alkenes have the double bond at the end of the carbon chain (on a terminal carbon), whereas internal alkenes have the double bond on non-terminal carbon atoms.

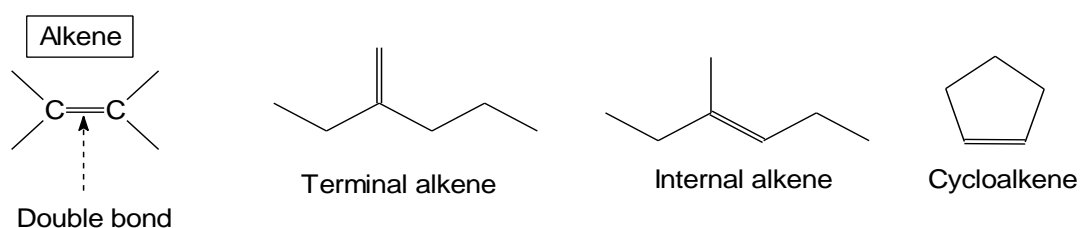

9.1.1 Structure of Alkenes

In alkenes the bond angles about each carbon in a double bond are about 120° . Both carbons are sp^2 hybridized and so the geometry of an alkene double bond is based on a trigonal plane. The alkene double bond is stronger than a single covalent bond and also shorter with an average bond length of 133 picometer. The C-H bonds are formed by overlap of sp^2 orbitals from the carbon overlapping with 1s orbital from the Hydrogen. The ethene C-H bonds contain more s character than the ethane C-H bonds and are therefore shorter and stronger. sp^2 has $1/3$ s, whereas sp^3 $1/4$ s character. s orbitals are closer to the nucleus and lower in energy. The carbon-carbon bond in ethene is shorter and stronger than in ethane partly because of the sp^2 - sp^2 overlap being stronger than sp^3 - sp^3 , but especially because of the extra π bond in ethene.

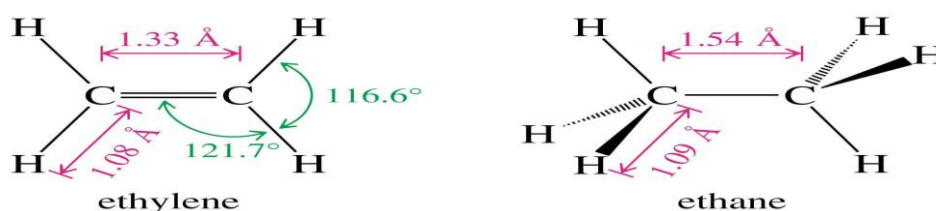

The π bond exists with half its electron density above the σ bond, and half below. The unhybridized 2p atomic orbitals, which lie perpendicular to the plane created by the axes of the three sp^2 hybrid orbitals, combine to form the pi bond.

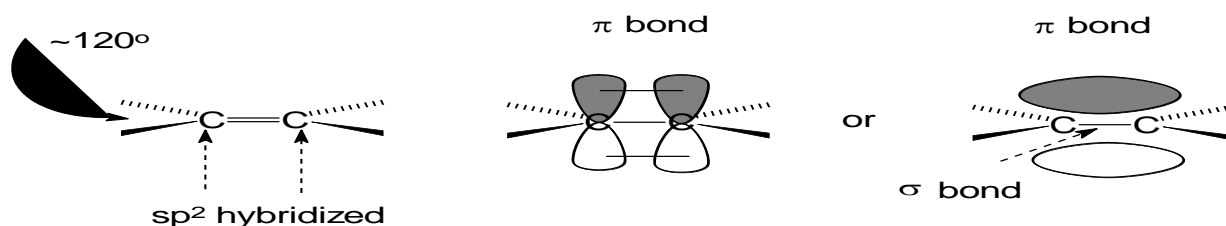

9.2 OBJECTIVES

After completing these unit learners able to:

- Learn the IUPAC nomenclature of alkanes.
- Understand the structure and bonding of alkenes geometry of disubstituted alkenes.
- Known the various methods of preparation, physical and chemical properties of alkenes.
- Draw the major product of the addition reaction of an alkene with diborane followed by basic hydrogen peroxide.
- Use Markovnikov's rule to predict the major product of an addition reaction of an alkene.
- Explain the difference between cumulated, isolated, and conjugated dienes, and be able to draw or recognize examples of these compounds.
- Explain why conjugated dienes have two preferred conformations (*s-cis* and *s-trans*), and how this is different from *cis* and *trans* stereoisomers of alkenes.
- Write the mechanism for a Diels-Alder reaction.

9.3 NOMENCLATURE OF ALKENE

According to IUPAC nomenclature, alkenes are identified by the suffix –ene. Number the chain beginning at the end closest to the double bond so that the double bond will have the lowest carbon number.

- Name branched or substituted alkenes in a manner similar to alkanes.
- Number the carbon atoms, locate and name substituent groups, locate the double bond, and name the main chain.
- *cis* and *trans* isomers must be designated by the appropriate *cis*- or *trans*- prefix.

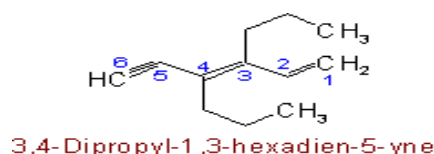
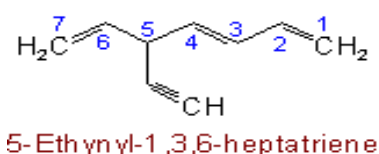

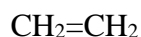

Ethene



Propene



2-Methylpropene



1-Hexene

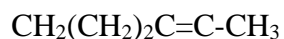

2-Hexene



1-Octene

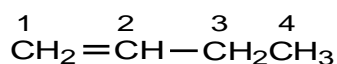

but-1-ene

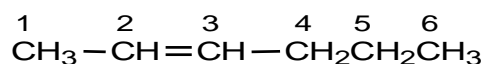

hex-2-ene

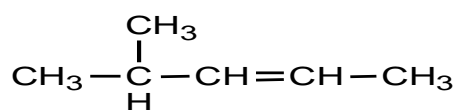

4-methylpent-2-ene

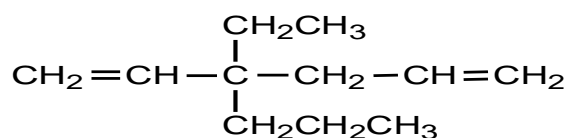

3-ethyl-3-propylhexa-1,5-diene

9.4 ISOMERISM OF ALKENE

The geometry of the C=C bond is determined by the π -bond. The rotation about the carbon-carbon double bond is very difficult and therefore severely restricted. As a consequence substituted alkenes exist as one of two isomers called a *cis* isomer and a *trans* isomer. When similar groups are on the same side of the double bond the alkene is said to be *cis*. When similar groups are bound to opposite side of the double bond it is said to be *trans*. *cis-trans* isomerism to occur there must be a double bond and two different groups on each of the double bonded carbon atoms. *E-Z* and *cis-trans* are different terms for the same type of isomerism.

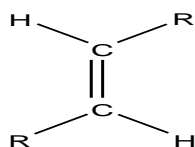
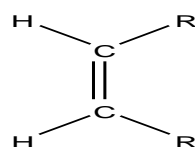
*E*- isomer (*trans*)*Z*- isomer (*cis*)

Example: Isomers of butene

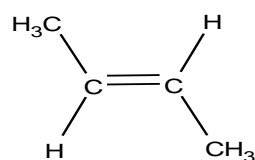

trans- But-2-ene

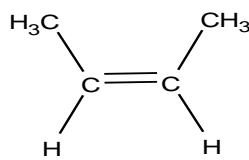

cis- But-2-ene

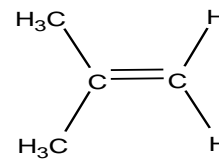

2-Methylpropene

The *cis* and *trans* isomers will be chemically very similar, though not quite identical, and will have slightly different melting and boiling points.

cis-2-Butene

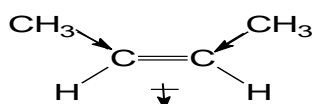

Small net dipole

B.p. 4 °C

+I effects reinforce

trans-2-Butene

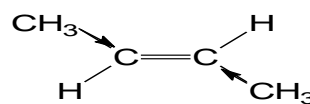

Zero net dipole

B.p. 1 °C

+I effects cancel

In general, a *cis* alkene is more polar than a *trans* alkene, giving it a slightly higher b.p. and making it somewhat more soluble in polar solvents.

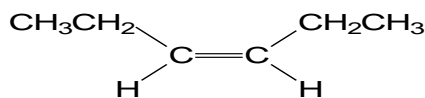

cis-3-hexene

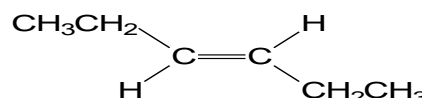

trans-3-hexene

9.5 METHODS OF PREPERATION

9.5.1 Dehydration of Alcohols

Dehydration is a process of removal of the H₂O from a substrate molecule. When heated with strong acids catalysts (most commonly H₂SO₄, H₃PO₄), alcohols typically undergo a 1, 2-elimination reactions to generate an alkene and water. The more stable alkene is the major product; this product may arise from the rearrangement of the original carbon skeleton.

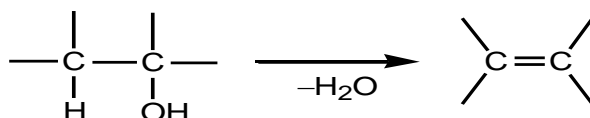

Tertiary alcohols are usually dehydrated under extremely mild conditions:

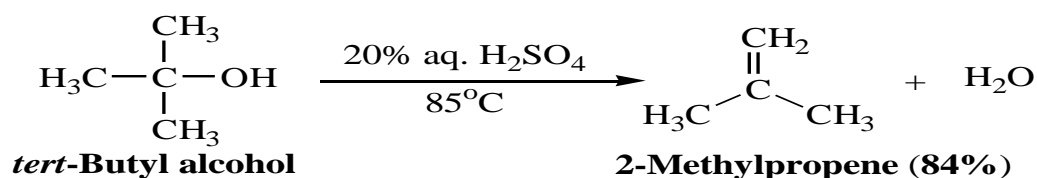

The dehydration of alcohols can also take place by passing the vapors of an alcohol over heated alumina (Al₂O₃) at 623K (350°C).

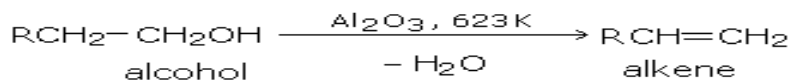

For example,

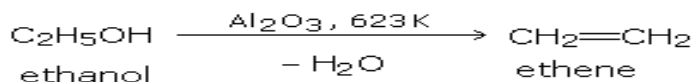

The order of the ease of dehydration of alcohols is, tertiary > secondary > primary.

9.5.2 Dehydrohalogenation of Alkyl Halides

Dehydrohalogenation is the removal of a halogen atom and a hydrogen atom from adjacent carbons. When heated with strong bases (sodium or potassium hydroxides or alkoxides) in alcohol, alkyl halides typically undergo a 1,2-elimination reaction to generate alkenes. Regioselectivity is usually controlled by the relative stability of the product alkenes. The most stable alkene is usually the major product if more than one product is possible.

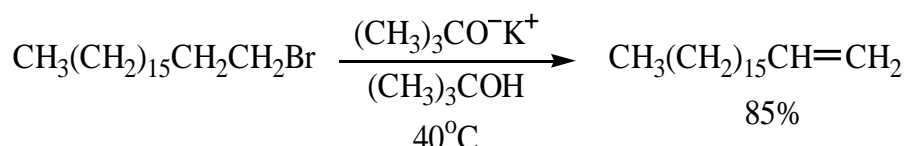
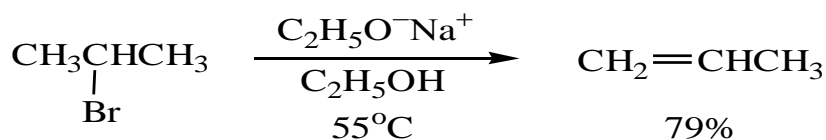
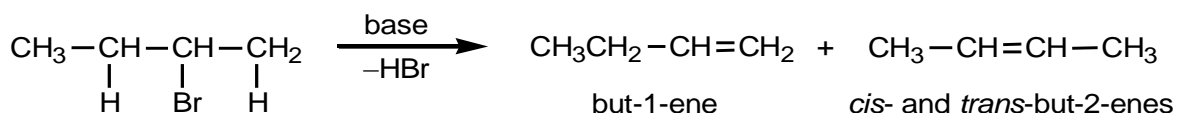
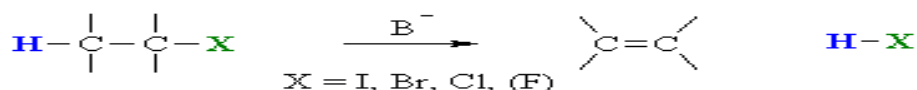

9.5.3 Reduction of Vicinal Dibromides

The action of zinc metal in acetic acid on vicinal dibromides to produce alkenes is elimination, a reduction and a dehalogenation reaction.

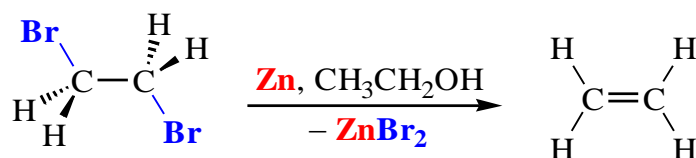

9.5.4 Dehydrogenation of alkanes

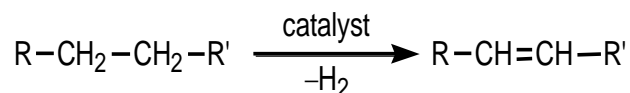

9.6 PHYSICAL PROPERTIES OF ALKENE

The physical properties of alkenes are comparable with alkanes. The physical state depends on molecular mass. The simplest alkenes, ethylene, propylene and butylene are gases. Like the alkanes, alkenes are nonpolar; insoluble in water; soluble in non polar organic solvents; less dense than water, flammable and nontoxic. Most alkenes, like alkanes exhibit only weak van der Waals interactions, so their physical properties are similar to alkanes of similar molecular weight. Alkenes have low melting points (m.p.) and boiling points (b.p.). M.p. and b.p. increase as the number of carbons increases because of increased surface area.

9.7 CHEMICAL REACTION OF ALKENE

The alkenes are more reactive than the alkanes because of the C=C bond. . The carbon-carbon double bond consists of a strong sigma bond and a weak pi bond. The typical reactions of alkenes involve the breaking of this weaker pi bond and formation of two new sigma bonds. Because of the presence of the multiple bonds, characteristic reactions are the electrophilic additions. It is possible for the double bond to break, allowing each carbon to form a new bond, which is often energetically favourable.

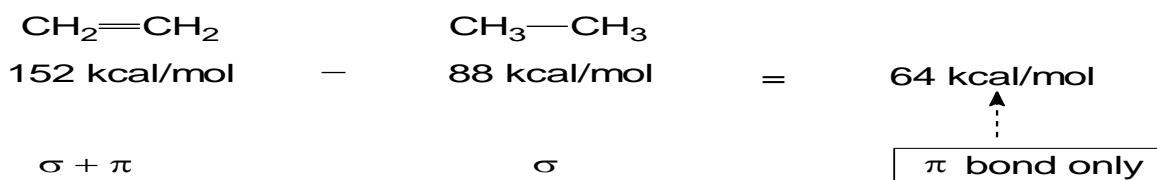

9.7.1 Hydrogenation

In the presence of finely divided metals like Ni, Pt, Pd, Rh, and Ru, addition of a hydrogen molecule takes place on alkene at room temperature. When the catalyst is in a different physical state to the other reactants it is called heterogeneous catalysis (E.g. a solid catalyst with a liquid and a gas). In contrast a liquid catalyst in a reaction solution is an example of

homogeneous catalysis (acid catalyzed alcohol dehydration). During catalytic hydrogenation, the hydrogen adsorbs onto the surface of the metal catalyst, and they add *syn* to the double bond. One face of the π system binds to the catalyst, then the bound hydrogen inserts into the π bond, and the product is liberated from the catalyst. This is a *syn* addition reaction, i.e., both hydrogen atoms attack from the same side of the molecule.

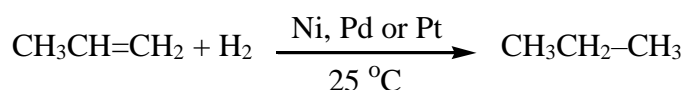
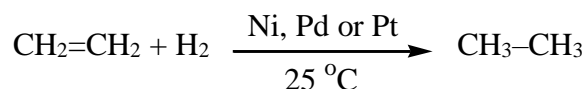
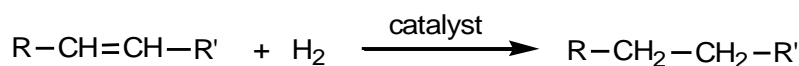

Finely divided metals activate molecular hydrogen and the hydrogen atoms add to the double bond. This is usually a *syn* addition, i.e., both hydrogen atoms attack from the same side of the molecule.

9.7.2 Electrophilic Addition

The most common chemical transformation of a carbon-carbon double bond is the addition reaction. The characteristic reaction of alkenes is electrophilic addition, because the π bond is both weak and electron rich (nucleophilic). An important feature of alkene reactivity is an ability to react with a variety of *electrophilic reagents*, those reagents attracted to the source of extra electron density. In an alkene, pi bond serves as a source of electron. An **electrophile** will attract pi electrons, and can pull them away to form a new bond. This leaves one carbon with only 3 bonds and a +ve charge (carbocation). The double bond acts as a **nucleophile** (attacks the electrophile). In most cases, the cation produced will react with another nucleophile to produce the final overall electrophilic addition product. Electrophilic addition is probably the most common reaction of alkenes.

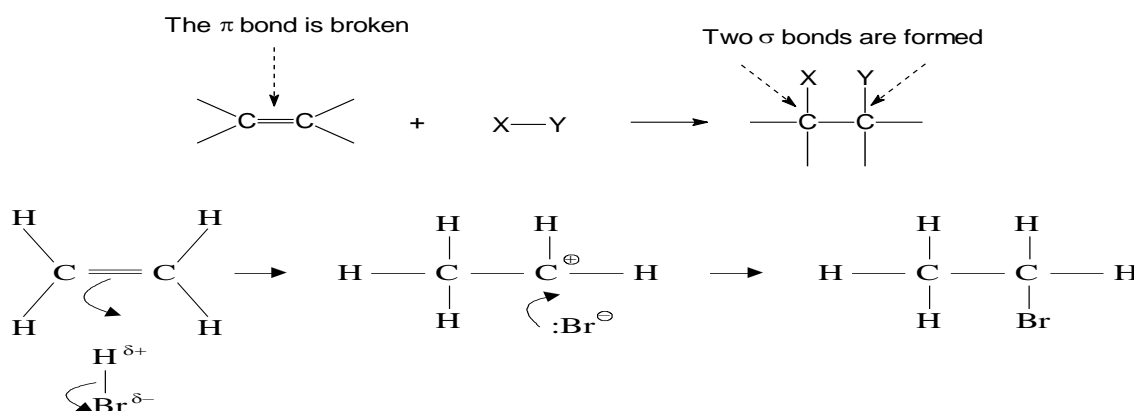

The alkene abstracts a **proton** from the HBr, and a carbocation and bromide ions are generated.

The bromide ion quickly attacks the cationic center and yields the final product. In the final product, H-Br has been added across the double bond.

Consider the addition of H-Br to 2-methyl-2-butene:

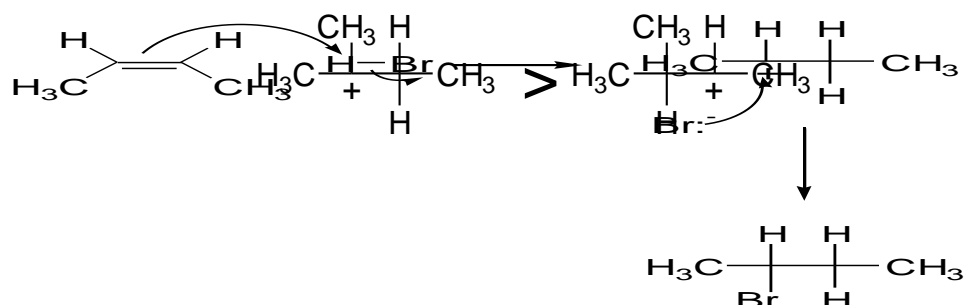

There are two possible products arising from the two different ways of adding H-Br across the double bond. But only one is observed. The observed product is the one resulting from the more stable carbocation intermediate.

Tertiary carbocations are more stable than secondary. The protonation occurs at the least highly substituted end so that the cation produced is at the most highly substituted end (and therefore more stable).

The acid-catalyzed process is a convenient method for the preparation of secondary and tertiary alcohols. The reaction is usually regioselective and follows *Markovnikov's rule*.

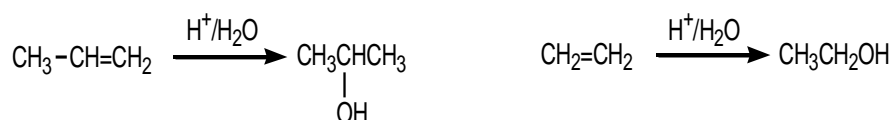

Mechanism:

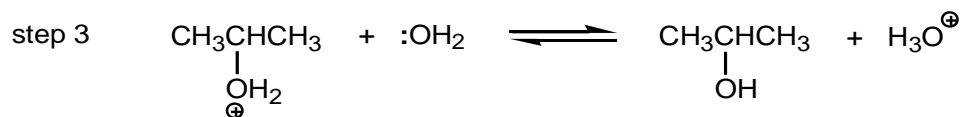
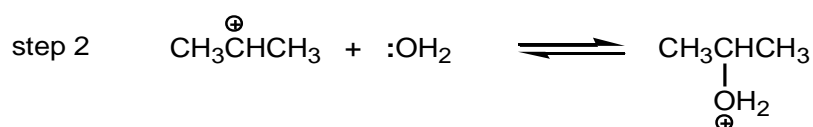
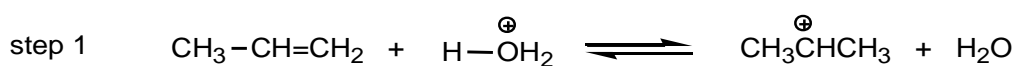

9.7.3 Markovnikov's Rule

After studying many addition reactions of unsymmetrical alkene, the Russian chemist Vladimir Markovnikov in 1869 noticed a trend in the structure of the favored addition product and formulated a rule. According to this rule "The addition of a halogen acid to the double bond of an unsymmetrical alkene results in a product with the acid hydrogen bound to the carbon atom that already has the greater number of hydrogens attached." Reactions that give such products are said to have Markovnikov orientation, and are Markovnikov products. The electrophilic addition of HBr is said to be **regiospecific**, since it only gives one orientation of addition.

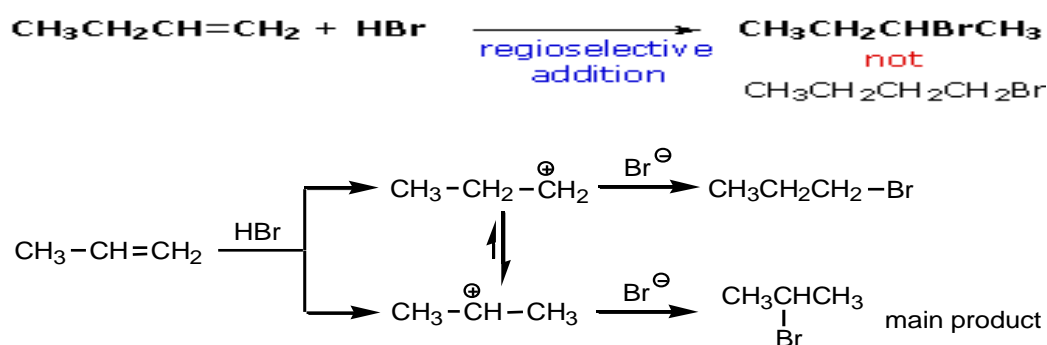

The basis of Markovnikov's rule is the formation of a carbocation in the rate-determining step. The modern statement of Markovnikov's rule: in the ionic addition of an unsymmetrical reagent to a double bond, the positive portion of the reagent attaches itself to the carbon so as to yield the more stable carbocation (lower energy). Rearrangements often occur during the addition of HX to alkenes, because of the involvement of carbocation intermediates.

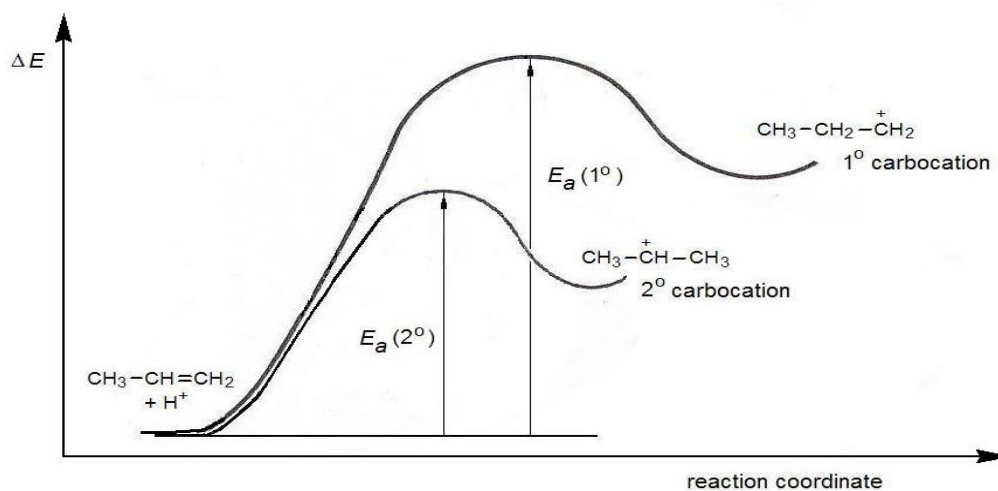
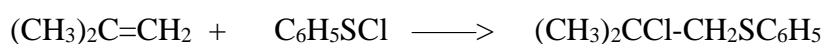
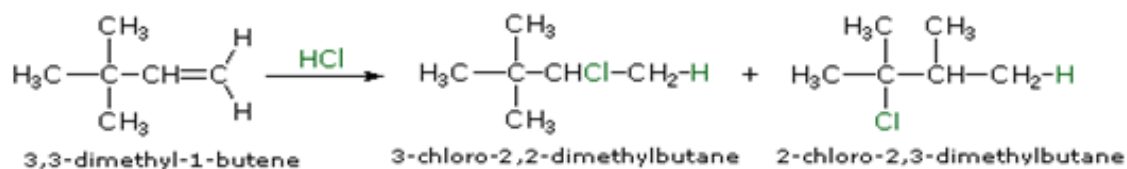
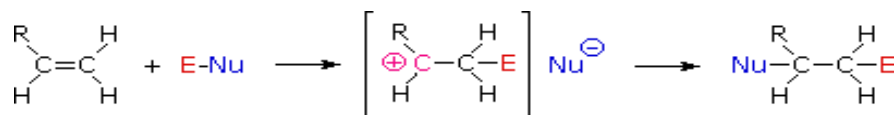

Figure 9.1: Potential energy diagram for the protonation of propene.



The regioselectivity of the above reactions may be explained by the same mechanism we used to rationalize the Markovnikov rule. Thus, bonding of an electrophilic species to the double bond of an alkene should result in preferential formation of the more stable (more highly substituted) carbocation, and this intermediate should then combine rapidly with a nucleophilic species to produce the addition product. This is illustrated by the following equation.



Free Radical addition to Alkenes: It is possible to obtain anti-Markovnikov products when HBr is added to alkenes in the presence of free radical initiators like peroxide. The free radical initiators change the mechanism of addition from electrophilic addition to free radical addition. This change of mechanism gives rise to the opposite regiochemistry.

Initiation: The oxygen-oxygen bond is weak, and is easily homolytically cleaved to generate two alkoxy radicals by thermal or light energy. The resulting alkoxy radical then abstracts a hydrogen atom from HX in a strongly exothermic reaction. Once a halogen atom is formed it adds to the π -bond of the alkene in the first step of a chain reaction. This addition is regioselective, giving the more stable carbon radical as an intermediate.

Propagation:

The halogen radical is electron deficient and electrophilic. The radical adds to the double bond, generating a carbon centered radical. This radical then abstracts hydrogen from a molecule of H-X, giving the product, and another halogen radical (Chain process). Each of the steps in this chain reaction is exothermic, so once started the process continues until radicals are lost to termination events. The orientation of this reaction is anti Markovnikov. The reversal of regiochemistry through the use of peroxides is called the **peroxide effect**.

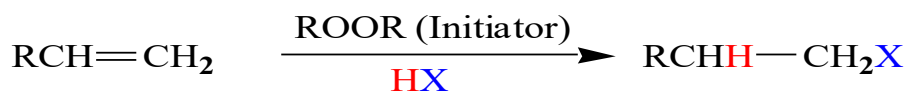

Tertiary radicals are more stable than secondary radicals. The reaction goes through the most stable intermediate

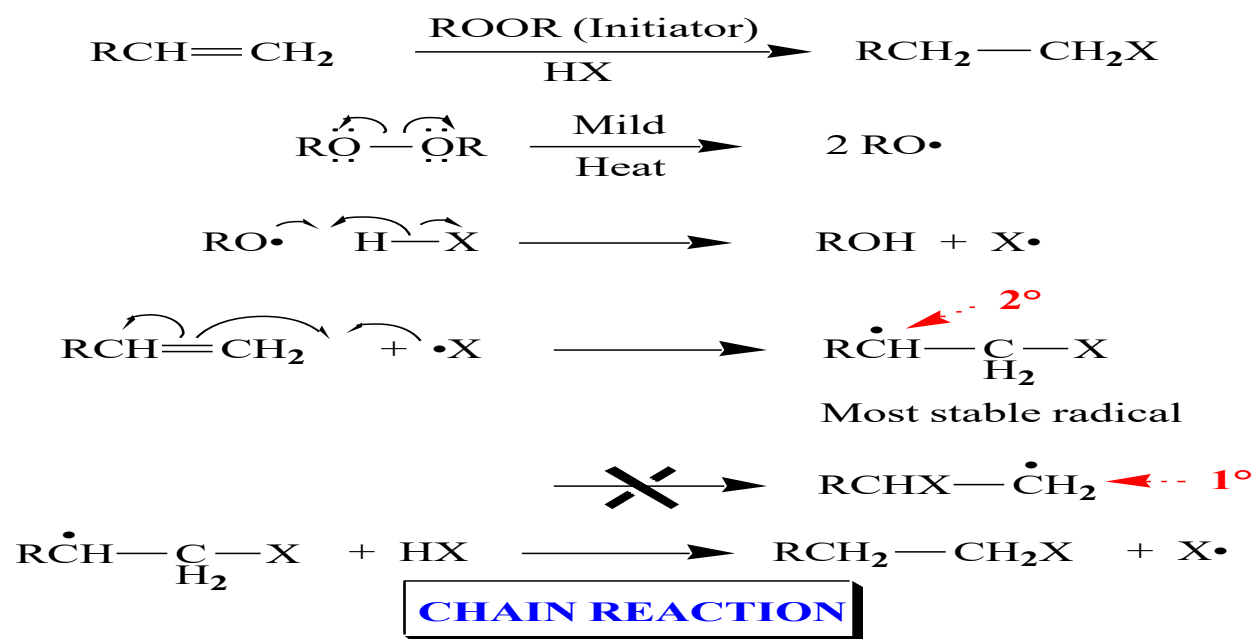

9.7.4 Hydroboration of Alkenes

Alkenes are capable of adding diborane to yield alkylboranes. Diborane is the dimer of a hypothetical borane, BH_3 . Borane has only six valence electrons and is very electron deficient. BH_3 act as a Lewis acid and can bond to the pi-electrons of a double, i.e., borane act as an electrophilic molecule, and reacts with double bonds in a one step process to generate an alkylborane. Intermediate alkylborane is not isolated but is oxidized with alkaline H_2O_2 to yield an alcohol. This is one of the most useful methods of preparing alcohols from alkenes.

Mechanism

Hydroboration-oxidation is a two-step reaction sequence that converts an alkene to an alcohol. Borane adds to alkenes with anti-Markovnikov orientation. The BH_2 fragment will be directed onto the least substituted carbon and the hydride onto the most substituted carbon. In the final product the hydroxy group will replace the BH_2 group giving rise to an overall anti-Markovnikov addition of H_2O to an alkene. Thus, the reaction is regioselective since it represents an overall syn-addition to the double bond. The overall result of hydroboration-oxidation is the syn addition of the elements of H and OH to a double bond.

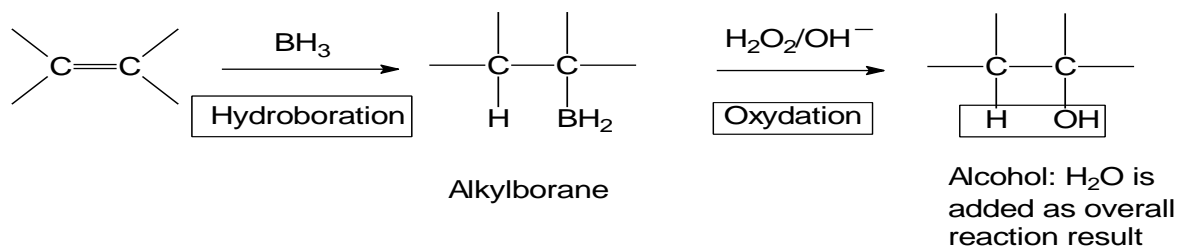

The di- and tri-alkyl boranes behave just as the alkylboranes, but for simplicity they are often written as mono alkylboranes.

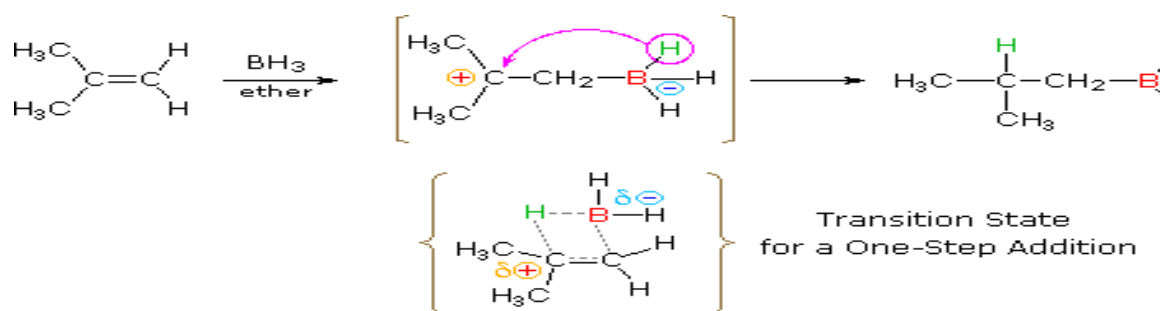

9.7.5. Oxymercuration-Demercuration

This is another alternative for converting alkenes to alcohols with Markovnikov orientation. This method has the advantage of not involving free carbocationic species, and thus removes the possibility of rearrangements. The reagent is called mercuric acetate, and is usually abbreviated to Hg(OAc)₂. In solution it ionizes into acetate ion and a positively charged mercury species which is very electrophilic and attack on a alkene double bond, giving a 3 membered ring compound called a mercurinium ion.

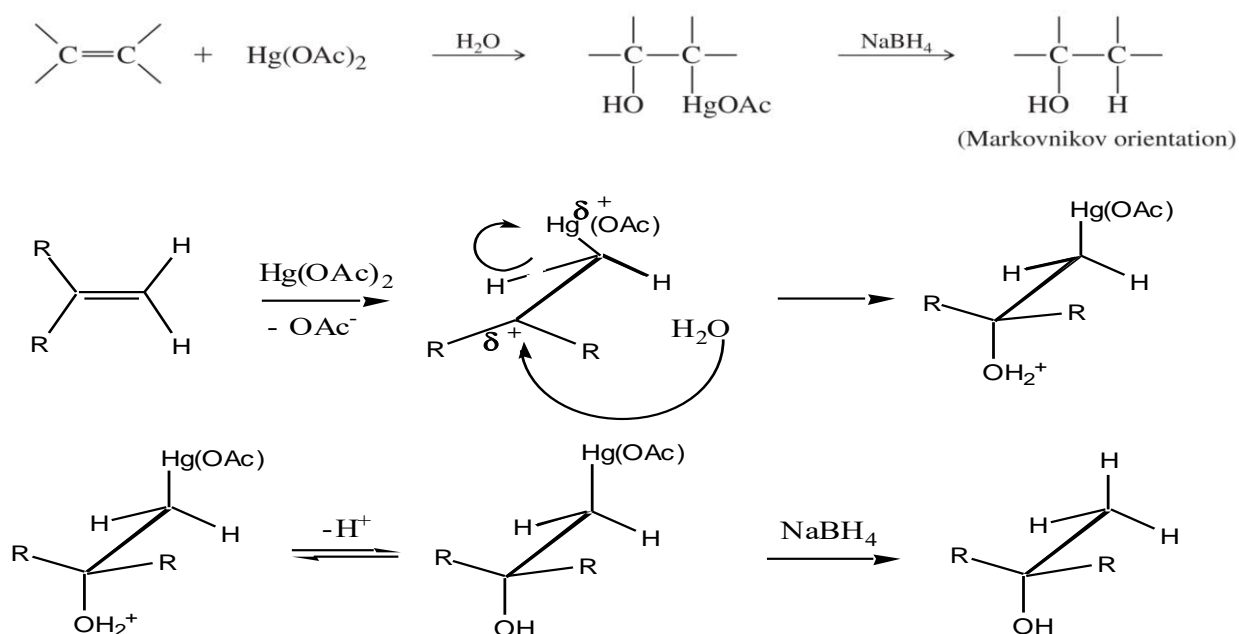

When water is present, the nucleophilic oxygen will open the mercurinium ring, and generate an organomercurial alcohol. Demercuration is the removal of the mercury containing species, which is achieved by reaction with sodium borohydride, a powerful reducing agent, which replaces the mercury species with a hydrogen atom – giving the desired alcohol. The opening of the mercurinium ion proceeds in the Markovnikov fashion, with the incoming H (this time as a *hydride*) being placed on the least substituted carbon. The reaction is *regioselective* since the water nucleophile will attack the carbon with positive charge since it represents an overall anti-addition H and OH groups to the double bond. Oxymercuration-demercuration also gives Markovnikov orientation of the alcohol. The electrophile $^+\text{HgOAc}$ remains bound to the less highly substituted carbon.

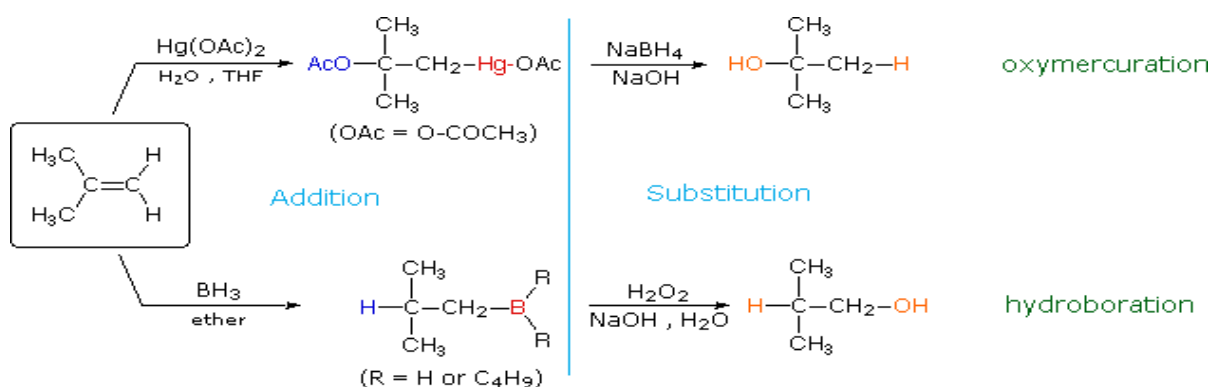

9.7.6 Ozonolysis

Ozone, O_3 , is highly reactive electrophile. Ozone adds to carbon-carbon double bonds forming a number of intermediates the most important of which is ozonide. Reactive ozonide is reduced by zinc in the presence of water to give aldehydes or ketones depending on the degree of substitution of the double bond. Each double bond yields two fragments if it is substituted asymmetrically. Both acyclic and cyclic alkenes are subject to degradative ozonolysis.

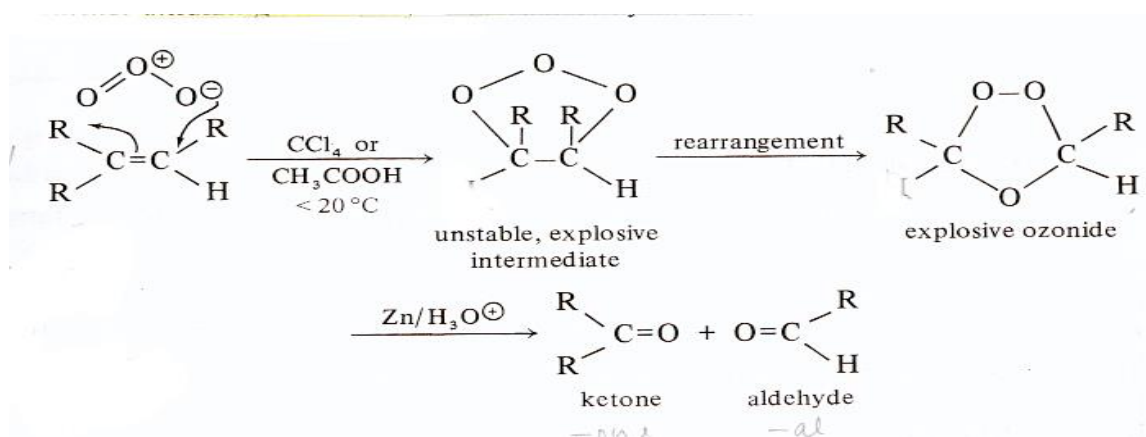

After reduction step of ozonolysis:

- (i) an alkene with an unsubstituted carbon atom yields formaldehyde
- (ii) an alkene with a monosubstituted carbon atom yields an aldehyde
- (iii) an alkene with a disubstituted carbon atom yields a ketone

Hence these reactions can be useful for the characterisation of molecules of unknown structure which contain carbon-carbon double bonds. The position of the double bond is clearly determined by ozonolysis method.

9.7.7 Oxidation with KMnO_4 and OsO_4

When alkenes are oxidised with cold, alkaline KMnO_4 , dihydroxy compounds (diols or glycols) are obtained. The KMnO_4 gets decolourised. This reaction is therefore, used as Bayer's test for unsaturation (the presence of double or triple bonds) in any molecule.

e.g., Ethene gives ethane-1,2-diol.

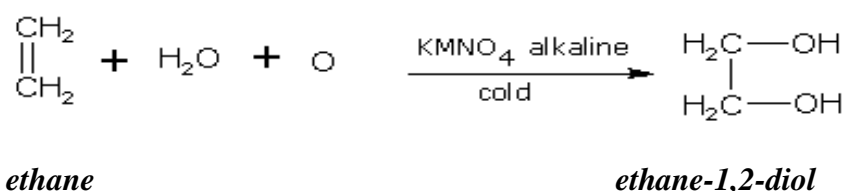

In basic solution the purple permanganate anion is reduced to the green manganate ion, providing a nice colour test for the double bond functional group. Permanganate and osmium tetroxide have similar configurations, in which the metal atom occupies the center of a tetrahedral grouping of negatively charged oxygen atoms. The reaction involves formation of the cyclic oxomanganese intermediate that is subsequently hydrolyzed in alkaline medium to give the desired product. Note that the reaction represents a syn-addition pathway and is a diastereoselective and stereospecific route to diols.

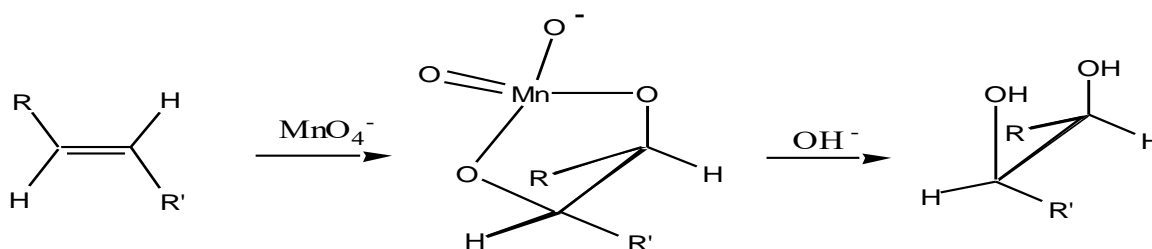

With Acidified potassium permanganate (or potassium dichromate) oxidises the dihydroxy compound so produced in reaction to ketone or carboxylic acid. For example,

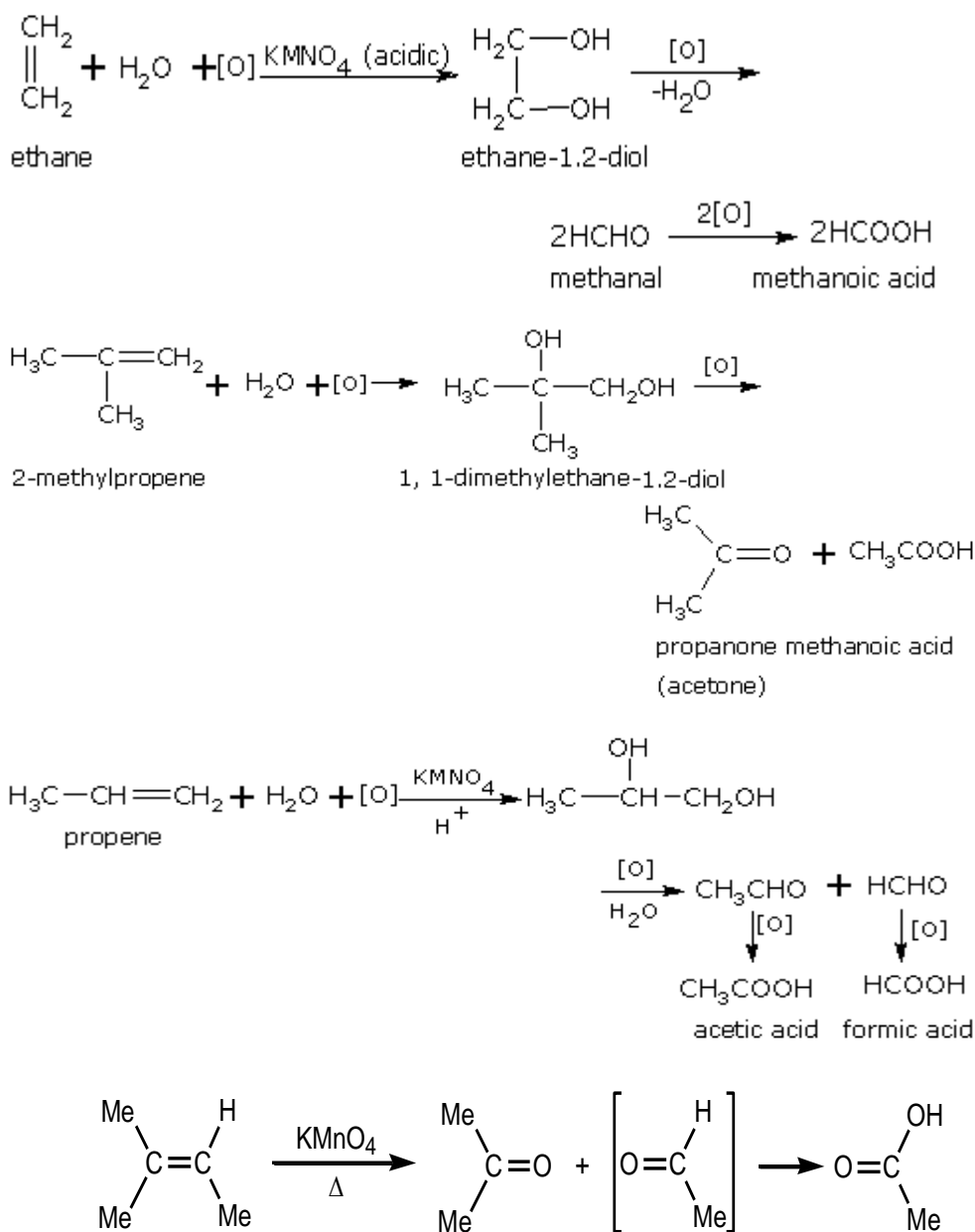

The purpose of this reagent is to replace the double bond with two oxygen atoms.

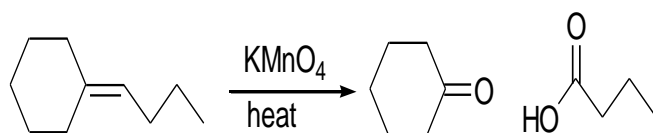

Therefore, one may expect to see two types of products: aldehydes and ketones. Hot KMnO_4 is a vigorous oxidizer. As the result, the oxidation is carried out further with aldehydes being oxidized to carboxylic acids and formaldehyde (CH_2O) to CO_2 and water. Ketones are resistant to oxidation and are therefore found as products under these conditions. Both acyclic and cyclic alkenes are subject to degradative ozonolysis.

Alkenes will also react with OsO_4 to form diols. The reaction involves formation of the cyclic osmate ester intermediate subsequently hydrolyzed in alkaline medium to give the desired product. The reaction represents a syn-addition pathway and is a diastereoselective and stereospecific route to diols.

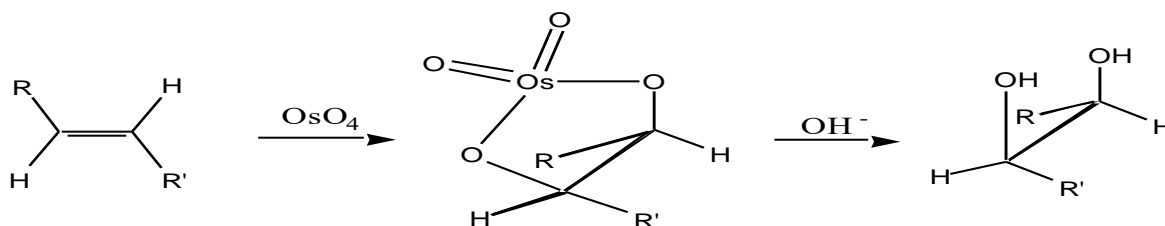

This reaction proceeds via a concerted electrophilic addition generating an osmate ester, which is hydrolyzed to a syn diol by hydrogen peroxide, which also reoxidizes the osmium catalyst. The two C-O bonds are formed at the same time with the cyclic ester, and the oxygen atoms are added at the same face of the π bond – syn orientation.

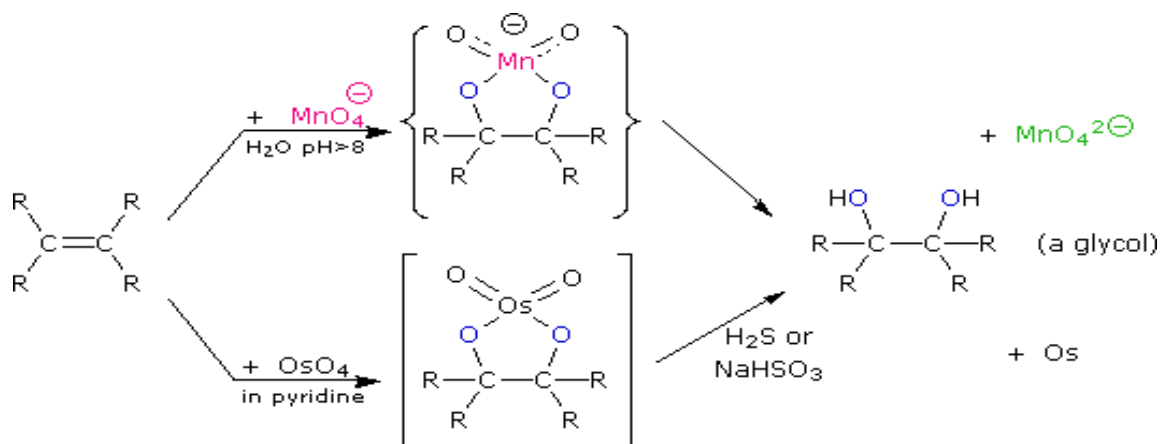

9.7.8 Polymerisation of alkenes

The process when monomer units are linked together to form polymeric material without the loss of material is called addition or chain-growth polymerization. The products, the addition or chain-growth polymers, are made of alkenes or substituted alkenes to produce polyethylene, polypropylene, polyisobutylene, polystyrene, polyvinyl chloride (PVC), polymethylmethacrylates, polyacrylonitriles, polytetrafluoroethylene (Teflon). Polymerization occurs in a stepwise manner through reactive intermediates. Polymerization can either proceed via a free-radical or an ionic mechanism.

When ethene is heated at high temperature under high pressure in presence of oxygen, we get polyethene

Example: Buta-1,3-diene

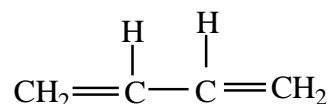

9.10 NOMENCLATURE AND CLASSIFICATION OF DIENES

Dienes can be divided into three classes, depending on the relative location of the double bonds:

- 1. Non- conjugated dienes (isolated dienes):** In this type of dienes the two double bonds are separated by more than one single bond are known as Non- conjugated dienes.

Examples:

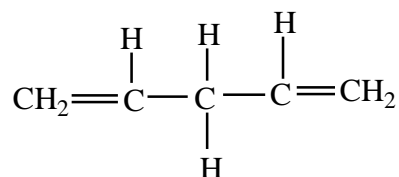

Penta-1,4-diene

- 2. Conjugated dienes:** In this type of dienes the two double bonds are separated by only one single bond are known as conjugated dienes.

Examples:

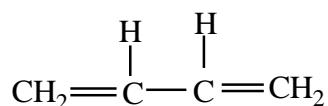

Buta-1,3-diene

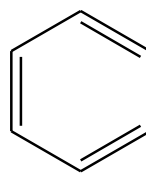

benzene

- 3. Cumulated dienes:** In this type of dienes the two double bonds are continuous, so these are named as cumulated dienes.

Examples:

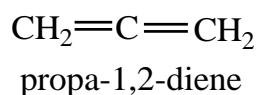

Nomenclature of dienes:

Dienes are alkenes with two double bonds. IUPAC name is same as alkene, but change -ene to -adiene and use two numbers to locate the two double bonds (number from the end of the chain which makes the smaller of these numbers smaller). A type of organic compounds, called **polyenes**, contains two or more double bonds. For example, **dienes** have two double bonds, and **trienes** have three. To name a diene or a triene, follow the same steps for naming an alkene with these exceptions.

Step 1 Write the numbers indicating the locations of the double bonds separated by commas and followed by a hyphen.

Step 2 After the hyphen; write the parent name of the compound, changing the ending from —ene to —diene, if there are two double bonds, or —triene, if there are three, etc.

The following example demonstrates how to name a polyene.

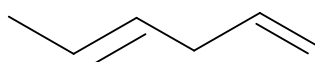

Step 1 Determine the length of the parent chain and the positions of the double bonds. The parent chain is six carbons long. There are two double bonds, and their positions are C1 and C4.

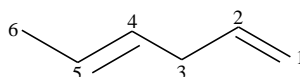

Step 2 Write the numbers of the locations of the double bonds followed by a hyphen: 1,4—.

Step 3 After the hyphen write the name of the parent chain with the —diene ending. The name of the compound is 1,4-hexadiene.

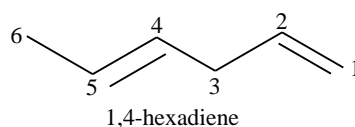

➤ **Some common diens and their IUPAC Nomenclature:**

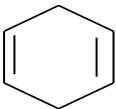
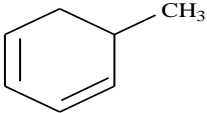
1. $\text{CH}_2=\text{CH}-\text{CH}=\text{CH}_2$ — 1,3- butadiene
2. $\text{CH}_2=\text{CH}-\text{CH}=\underset{\text{CH}_3}{\text{C}}-\text{CH}_3$ — pent- 4- methyl-1,3-diene
3.  — 1,4-hexadiene
4.  — 5-methyl-1,3-hexadiene

9.11 STRUCTURE OF ALLENES AND BUTADIENES

9.11.1 Structure of allenes

An allene is a compound in which one carbon atom has double bonds with each of its two adjacent carbon centres. Allenes are classified as polyenes with cumulated dienes. The parent compound of allene is propadiene. Compounds with an allene-type structure but with more than three carbon atoms are called cumulenes. Allenes are much more reactive than most other alkenes.

The central carbon of allene forms two sigma bonds and two pi bonds. The central carbon is sp -hybridized, and the two terminal carbons are sp^2 -hybridized. The bond angle formed by the three carbons is 180° , indicating linear geometry for the carbons of allene. It can also be viewed as an "extended tetrahedral" with a similar shape to methane.

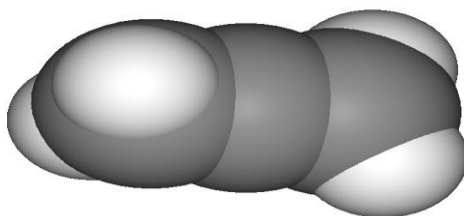

3-D- structure of Allene

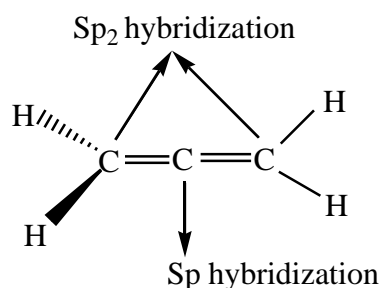

9.11.2 Structure of 1,3-butadiene

Each carbon in buta-1,3-diene is sp^2 hybridization and the sp^2 hybridized orbital of C_1 is overlap with $1s$ orbital of 2 H atom to form sp^2-s σ -bond and also sp^2 orbital of C_2 to form sp^2-sp^2 σ -bond. Similarly C_4 and C_2 overlap with $1s$ of 1H atom to form sp^2-s σ -bond and it is also overlapped with C_1 and C_3 . Hence the σ bond structure of 1,3-butadiene is represented as

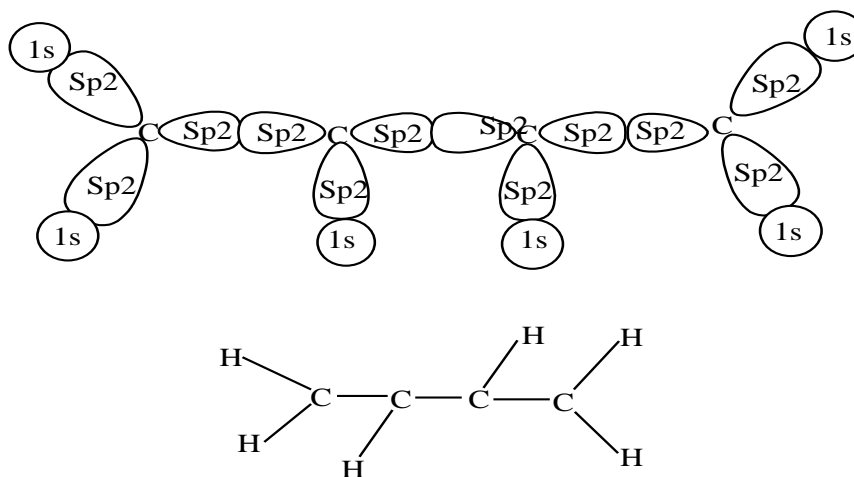

In 1,3-butadiene each carbon consists of one unhybridized p-orbital which overlaps from the nearest carbon atoms to form the π -bond by π -electron cloud. This is known as delocalization of π -electrons.

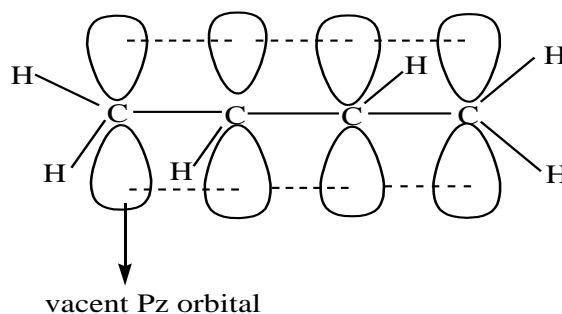

9.12 METHODS OF FORMATION

- From 1,4-dichloro butane:** 1,4-dichloro butane on react with alc. KOH gives buta-1,3-diene.

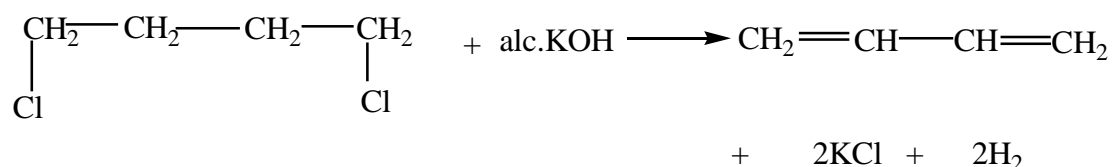

- From 1, 4- butane diol:** Bute 1,4- diol on react with conc. H_2SO_4 from 160-170 $^\circ\text{C}$ temperature gives bute-1,3-diene.

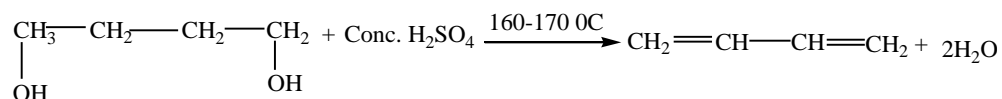

- From n- butane:** n-butane on heating in the presence of $\text{Cr}_2\text{O}_7\text{-Al}_2\text{O}_3$ at 600 $^\circ\text{C}$ than it gives 1,3-butadiene.

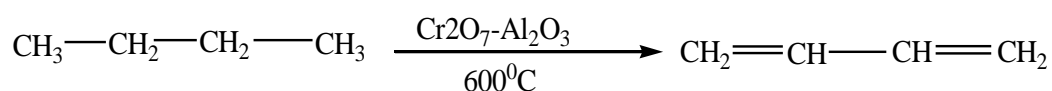

9.13 CHEMICAL REACTIONS

1. **Addition of halogens:** 1,3-butadiene when react with halogens in the presence of catalyst than it gives 1,2 and 1,4 addition products.

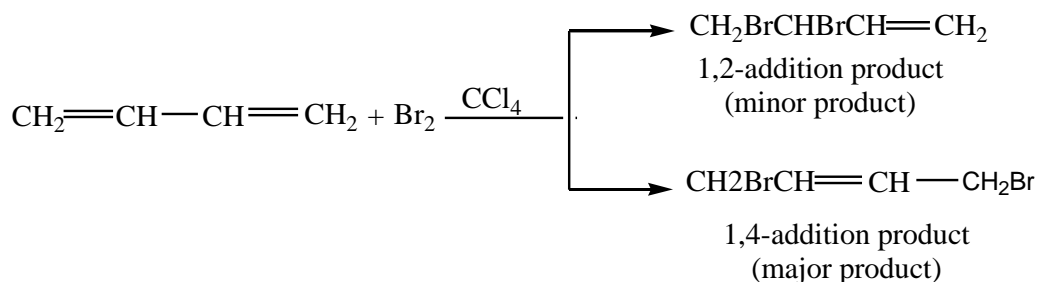

2. **Diels-Alder reaction:** In this reaction buta-1,3-diene is react with unsaturated compound such as alkene, alkyne etc. to form the product without any catalyst. This reaction is known as Diels-alder reaction and the product formed by the reaction is known as adduct.

E.g.

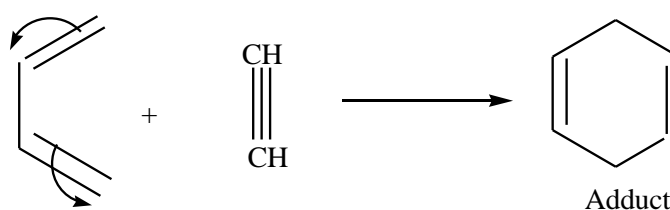
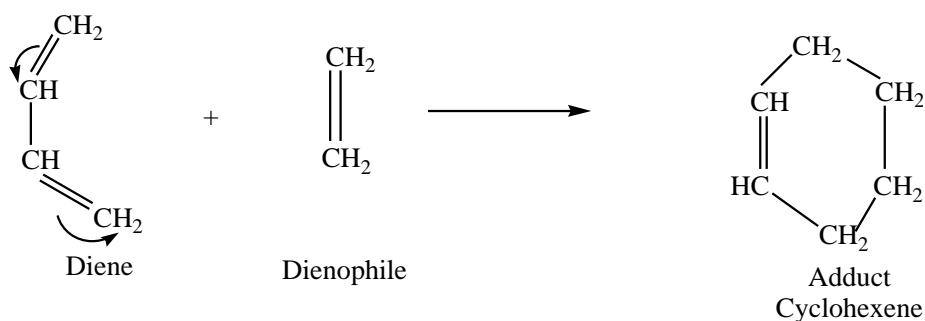

3. **Polymerization Reaction:** n-molecules of 1,3-butadiene are polymerize to give the addition polymer.

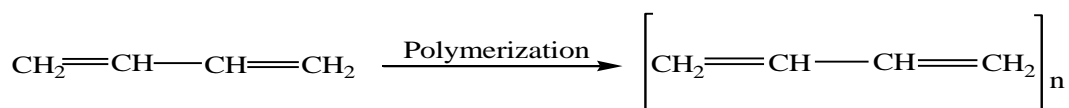

4. **Hydrogenation:** In the presence of Ni catalyst buta-1,3-diene on react with H_2 gives n-butane.

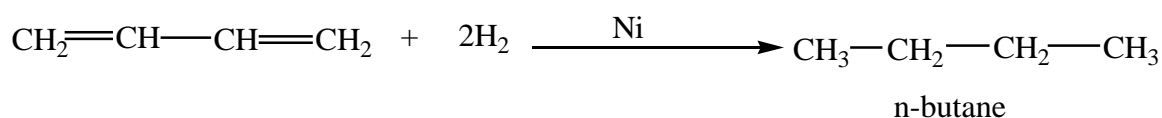

9.14 SUMMARY

- The major characteristics of the addition reactions covered in this chapter are summarized in the table below.

Reagent	Product	Mechanism	Regioselectivity	Stereochemistry
HX	Alkyl halide	2 step <i>via</i> rate-determining formation of R ⁺ . Rearrangements possible	Markovnikov	Syn and anti addition
H ₂ O	Alcohol	As above	As above	As above
X ₂ /H ₂ O	Halohydrin (2-haloalcohol)	3 steps, but similar to halogenations	Markovnikov: X ⁺ bonds to less substituted C.	Anti addition
BH ₃ (or equivalent), then H ₂ O ₂ /OH ⁻	Alcohol	2 steps: one-step hydroboration, then oxidation. No rearrangements	Anti-Markovnikov	Syn addition in hydroboration step; retention of configuration in oxidation step

- Summary of reactions involved in the alkene

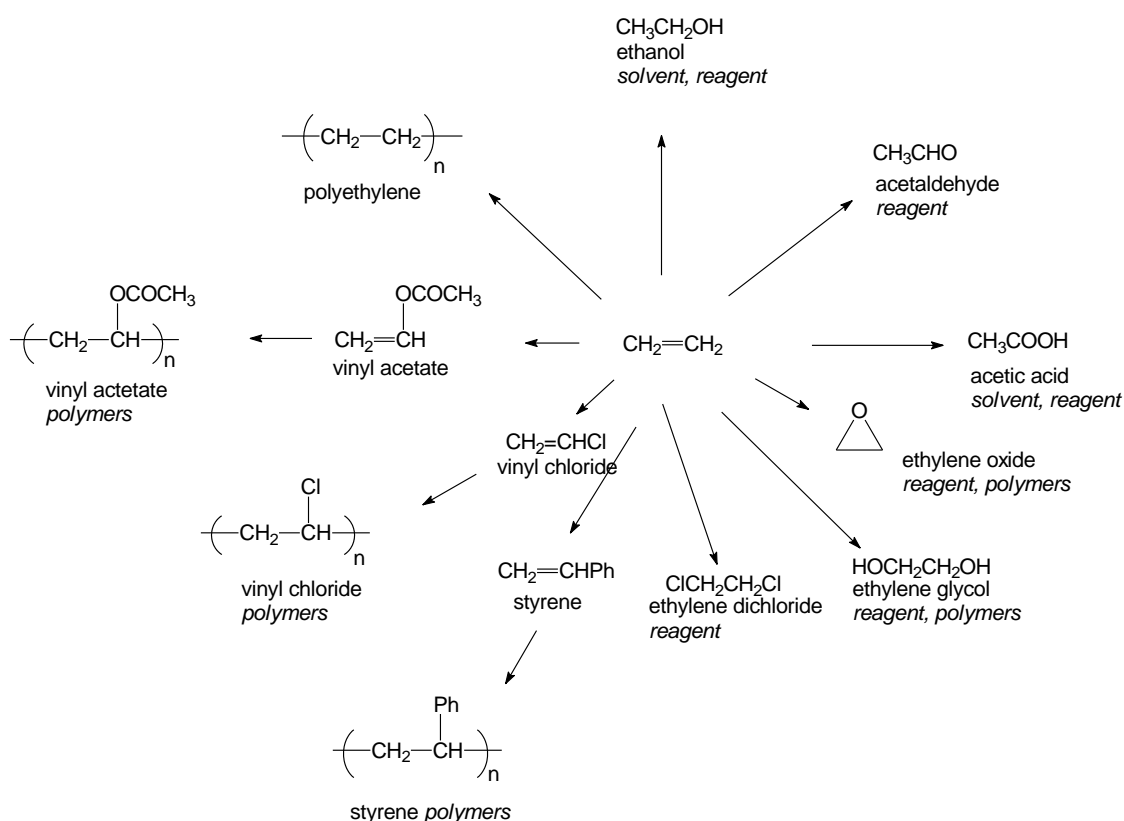

- The major and minor product (stereochemistry) of addition reaction of alkene determined by the Markovnikov rule.
- In Conjugated dienes, the conjugated double bonds are separated by one single bond and isolated double bonds are separated by more than one single bond while Cumulated double bonds are adjacent to each other.
- A conjugated diene is more stable than an isolated diene, which is more stable than a cumulated diene.
- An isolated diene, like an alkene, undergoes only 1,2- addition.
- A conjugated diene reacts with a limited amount of electrophilic reagent to form a 1,2-addition product and a 1,4-addition product.
- In a Diels–Alder reaction, a conjugated diene ($4\pi e^-$) reacts with a dienophile ($2\pi e^-$) to form a cyclic compound; in this concerted cycloaddition reaction, two new bonds are formed at the expense of two bonds.. The reactivity of the dienophile is increased by electron-withdrawing groups attached to the carbons.

9.15 TERMINAL QUESTIONS

Q.1 Provide the major product for each of the following reactions, showing stereochemistry where appropriate.

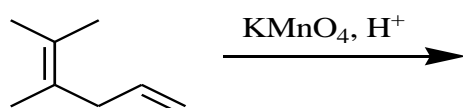
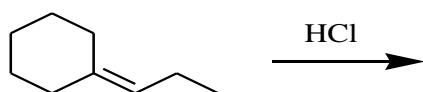
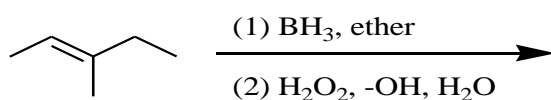
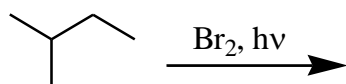

Q.2 Write the major product of the following reaction:

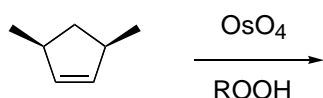

Q.3 Find out the structure of the major product formed from the following reactions. Justify your selections.

(i)

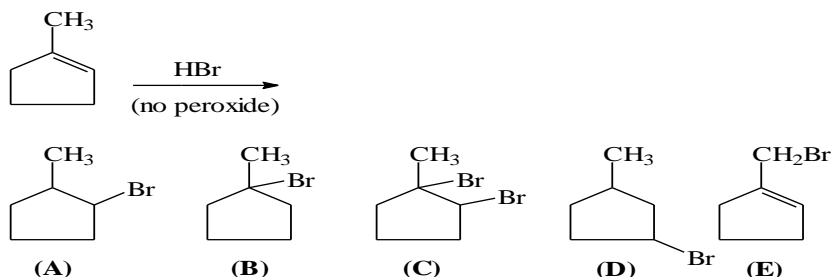

(ii)

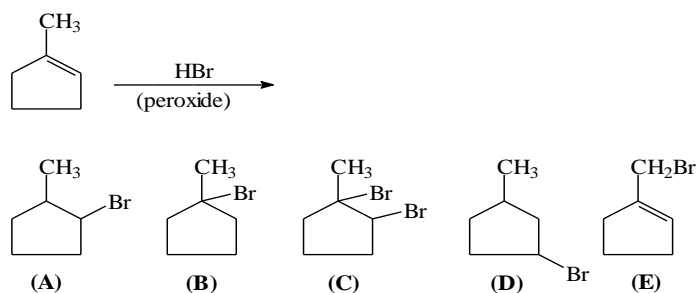

Q.4 Discuss the Markovnikov rule for the stereochemistry determination of addition reaction of alkene.

Q.5 Write short note on Diels–Alder reaction?

Q.6 Discuss why conjugated diene is more stable than non-conjugated diene.

Q.7 Give the mechanism of 1,2 and one four addition reaction of 1,3 butadiene.

9.16 BIBLIOGRAPHY

1. Advanced Organic Chemistry by, Jagdamba Singh and L.D.S. Yadav, Pragati Prakashana.
2. Paula Yurkanis Bruice 4th edition.
3. Organic Reactions and Their Mechanisms, by P. S. Kalsi, New edge Science.
4. R. L. Madan, S. Chand and company Pvt. Ltd.

UNIT 10: ALKYNE

CONTENTS:

- 10.1 Introduction
- 10.2 Objectives
- 10.3 Nomenclature and classification
- 10.4 Structure and bonding in alkynes
- 10.5 Methods of formation
- 10.6 Physical properties
- 10.7 Chemical reactions of alkynes
 - 10.7.1 Acidity of alkynes
 - 10.7.2 Mechanism of electrophilic and nucleophilic addition reactions
 - 10.7.3 Oxidation and polymerization
- 10.8 Summary
- 10.9 Terminal Question
- 10.10 Bibliography

10.1 INTRODUCTION

Alkynes are hydrocarbons which contain carbon-carbon triple bond. The triple bond is indicated by changing the ending of the name to -yne, in the same manner as the double bonds in alkenes are indicated by the ending -ene. Alkynes, like alkenes are unsaturated hydrocarbons with the general formula C_nH_{2n-2} . Their suffix is -yne and the IUPAC name of them is written as Alkane-ane+ yne = Alkyne. For example, ethyne the simplest alkyne, which is more commonly known by its common name **acetylene**, is a gas often used as a fuel for cutting and welding torches because it burns with a very hot flame?



(Structure of Ethyne, Acetylene)

The first stable member of alkyne series is ethyne which is popularly known as acetylene. Acetylene is used for arc welding purposes in the form of oxyacetylene flame obtained by mixing acetylene with oxygen gas. Alkynes are starting materials for a large number of organic compounds. Hence, it is interesting to study this class of organic

The first few members of this series are represented by the following structures:

Name	Structure	Condensed structure
Ethyne	$\text{H}-\text{C}\equiv\text{C}-\text{H}$	$\text{HC}\equiv\text{CH}$
Propyne	$\begin{array}{c} \text{H} \\ \\ \text{H}-\text{C}\equiv\text{C}-\text{C}-\text{H} \\ \\ \text{H} \end{array}$	$\text{HC}\equiv\text{CCH}_3$
But-1-yne	$\begin{array}{c} \text{H} \quad \text{H} \\ \quad \\ \text{H}-\text{C}\equiv\text{C}-\text{C}-\text{C}-\text{H} \\ \quad \\ \text{H} \quad \text{H} \end{array}$	$\text{HC}\equiv\text{CCH}_2\text{CH}_3$
But-2-yne	$\begin{array}{c} \text{H} \quad \quad \quad \text{H} \\ \quad \quad \quad \\ \text{H}-\text{C}-\text{C}\equiv\text{C}-\text{C}-\text{H} \\ \quad \quad \quad \\ \text{H} \quad \quad \quad \text{H} \end{array}$	$\text{CH}_3\text{C}\equiv\text{CCH}_3$
Pent-1-yne	$\begin{array}{c} \text{H} \quad \text{H} \quad \text{H} \\ \quad \quad \\ \text{H}-\text{C}\equiv\text{C}-\text{C}-\text{C}-\text{C}-\text{H} \\ \quad \quad \\ \text{H} \quad \text{H} \quad \text{H} \end{array}$	$\text{HC}\equiv\text{CCH}_2\text{CH}_2\text{CH}_3$
Pent-2-yne	$\begin{array}{c} \text{H} \quad \quad \quad \text{H} \quad \text{H} \\ \quad \quad \quad \quad \\ \text{H}-\text{C}-\text{C}\equiv\text{C}-\text{C}-\text{C}-\text{H} \\ \quad \quad \quad \quad \\ \text{H} \quad \quad \quad \text{H} \quad \text{H} \end{array}$	$\text{CH}_3\text{C}\equiv\text{CCH}_2\text{CH}_3$

10.2. OBJECTIVES

- Explain the difference between alkynes and unsaturated compounds with carbon carbon triple bonds.
- Nomenclature of Alkynes
- Hybridization and bond formation of Alkynes
- Explain how the sigma and two pi bonds are formed in a C---C.
- Explain how carbon-carbon single, double, and triple bonds compare in length.
- Give the physical properties of alkynes, including polarity, water solubility, flammability, and odor.
- Chemical Reactions of Alkynes.

10.3 NOMENCLATURE AND CLASSIFICATION

The naming of the alkynes follows the exact rules as those used for naming alkenes except, of course, that the suffix *-yne* is used to indicate that a triple bond is now present.

Naming Alkynes:

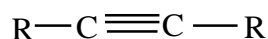

Where, both R will be H or same alkyl group

- b. Non-terminal alkynes:** Non-Terminal Alkynes, on the other hand have triple bond at any place other than the end positions.

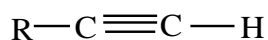

10.4 STRUCTURE AND BONDING IN ALKYNES

Each carbon atom of ethyne has two sp hybridised orbitals. Carbon-carbon sigma (σ) bond is obtained by the head to head overlapping of the two sp hybridised orbitals of the two carbon atoms. The remaining sp hybridized orbital of each carbon atom undergoes overlapping with the $1s$ orbital of each of the two hydrogen atoms in the same plane to form two C-H sigma bonds. The H-C-C bond angle is of 180° . Each carbon has two unhybridised p orbitals which are perpendicular to each other as well as to the plane of the C-C sigma bond. The $2p$ orbitals of one carbon atom are parallel to the $2p$ orbitals of the other carbon atom, which undergo sidewise overlapping to form two π bonds between two carbon atoms. Thus ethyne bonds. Thus, σ bonds and two C-C π bond, two C-H σ molecule consists of one C-C σ ethyne is a linear molecule.

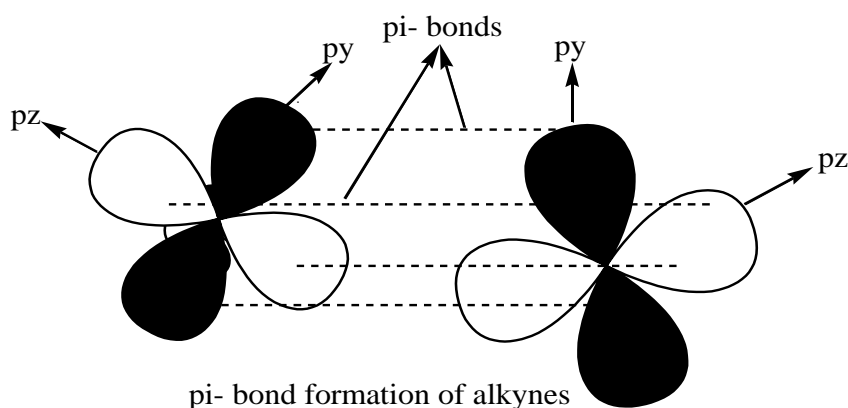
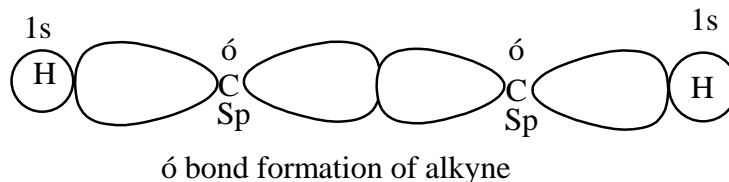

10.5 METHODS OF FORMATION

- 1. From Vicinal di- halides:** Vic. di halides on react with alc. KOH gives alkynes.

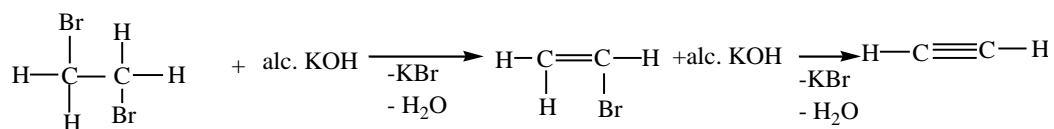

2. From gem. dihalides: 1,1- dihalides are known as gemdihalides, gem-dihalides on react with alc. KOH gives alkyne.

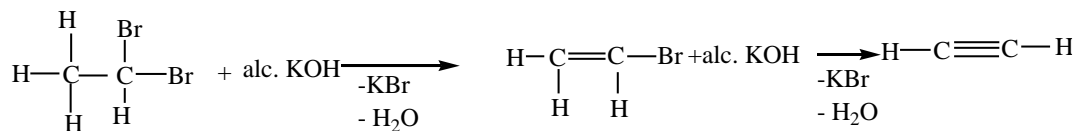

3. From tetra halides: Tetra halides on react with Zn form alkynes.

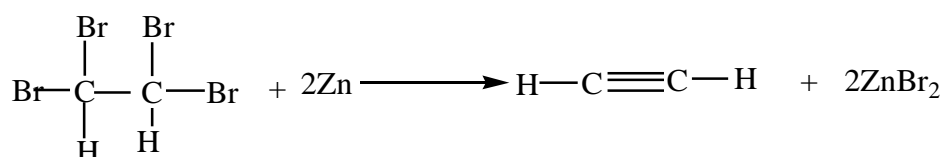

4. From Chloroform: The trihalogen derivatives of CH_4 are known as haloform. Such as CHX_3 ($\text{X} = \text{Cl}, \text{Br}, \text{I}$). Chloroform on react with Ag powder gives acetylene.

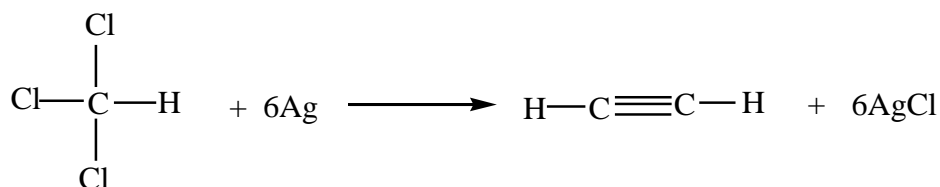

5. From Kolbey's electrolysis method: The Na or K salt of malic acid on react with H_2O and after electrolysis gives acetylene and CO_2 at anode and H_2 and NaOH at cathode.

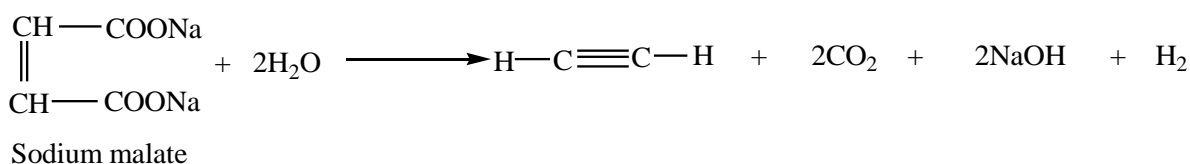

10.6 PHYSICAL PROPERTIES

1. Physical State:

The first three members of alkynes are gases while those containing five to thirteen carbon atoms are liquids and higher alkynes are solids.

2. Melting and Boiling Points:

The melting and boiling points of alkynes are quite low and increase regularly with increase in molecular mass. Alkynes are less volatile than alkanes and alkenes.

3. Solubility:

Alkynes are insoluble in water but are soluble in organic solvents such as benzene, hexane, ether, carbon tetrachloride, etc.

4. Density:

All alkynes are lighter than water. Their densities increase regularly with increase in molecular mass.

10.7 CHEMICAL REACTIONS OF ALKYNES**1. Electrophilic Addition Reactions**

Carbon-carbon triple bond, C≡C, is a combination of one and two bonds. Alkynes give electrophilic addition reactions as they show reactivity due to the presence of bonds. This property is similar to alkenes but alkynes are less reactive than alkenes towards electrophilic addition reactions due to the compact CC electron cloud. Some typical electrophilic addition reactions given by alkynes are:

- a. Addition of hydrogen:** An alkyne reacts with hydrogen in the presence of catalyst (Pt or Ni) at 250°C, first forming alkenes and finally alkane.

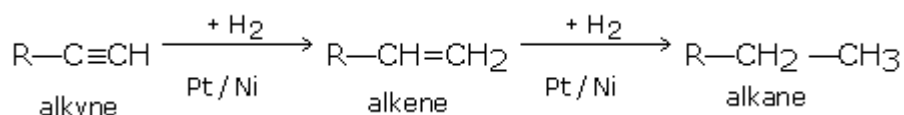

For example, ethyne gives ethane in two steps.

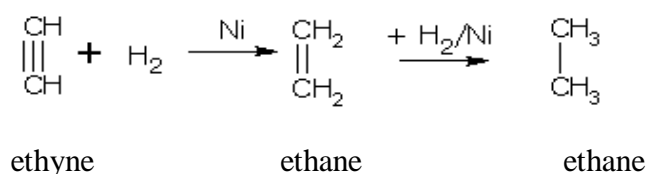

- b. Addition of Halogens:** Alkynes when react with halogens (Cl₂ or Br₂) in the dark, initially it gives dihaloalkenes and then finally gives tetrahalo alkanes. The reaction gets accelerated in the presence of light or halogen carriers.

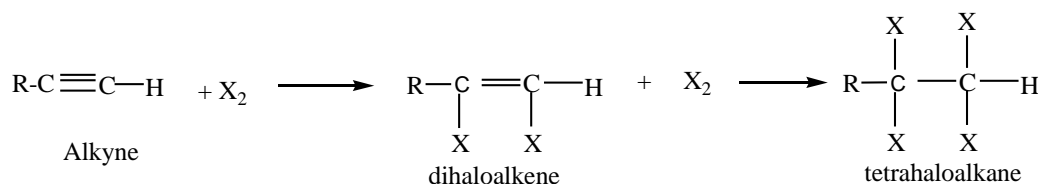

For example, ethyne (acetylene) with chlorine gives,

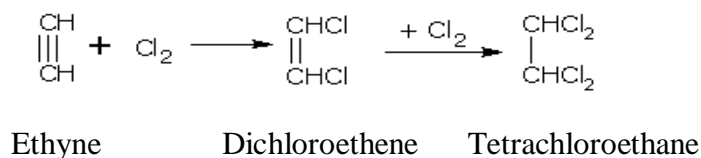

- c. Addition of Halogen Acids:** Alkynes reacts with halogen acids (HX, X= Cl, Br, I) according to the Markownikoff's rule to give initially mono-halo alkenes and then finally gives di-halo alkanes.

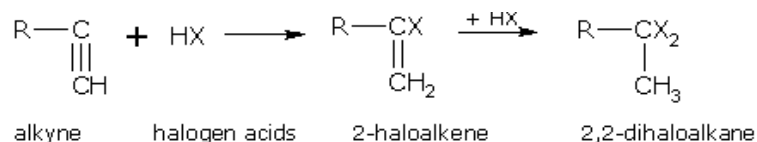

For example, ethyne (acetylene) with HBr gives,

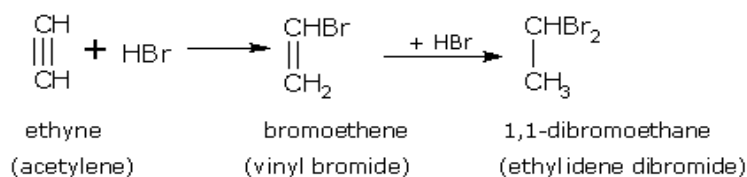

- 2. Substitution Reactions:** Due to their acidic nature, alkynes form metallic salts called alkynides i.e. sodium, silver and copperous salts.

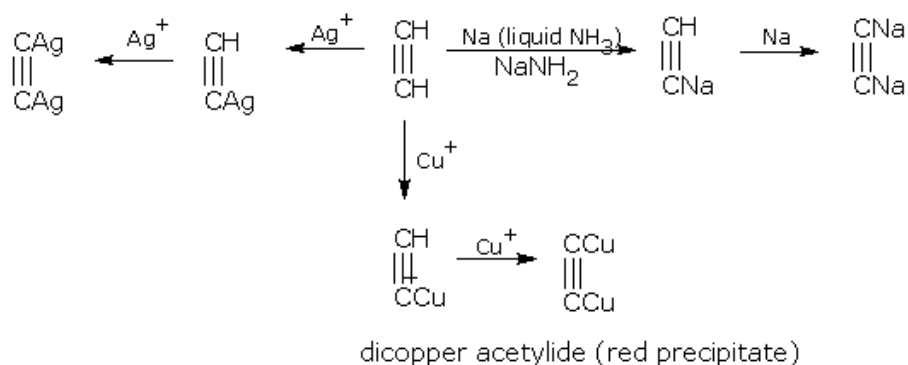

3. Hydrogenation:

- a. Uncontrolled hydrogenation:** In the presence of Ni catalyst alkyne on react with H₂ gives alkane.

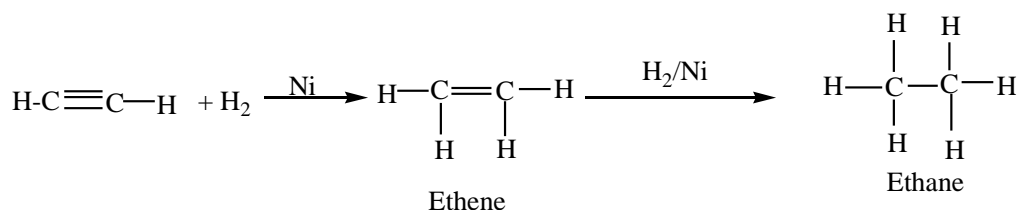

- b. **Controlled hydrogenation:** Alkynes on react with H₂ in the presence of Pd-CaCO₃/Quinolin gives alkene. This reaction is known as controlled hydrogenation of alkenes.

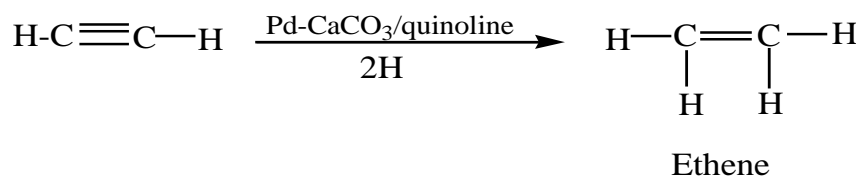
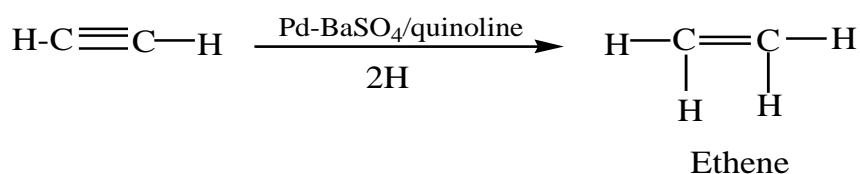

4. **Polymerization:** In the presence of red hot Cu tube, three molecules of C₂H₂ are undergoes polymerization and give a polymer C₆H₆. This reaction is known as polymerization of C₂H₂.

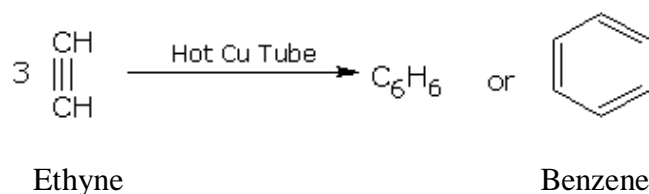

5. **Oxidation:** Oxidation of alkynes gives mono or dicarboxylic acids.

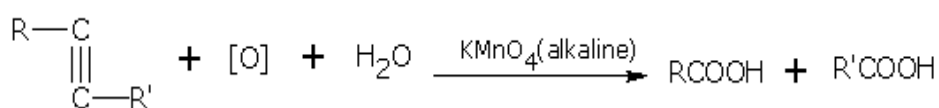

6. **Ozonolysis:** In the presence of CCl₄ alkyne on react with O₃ gives alkyne ozonimide which on react with Zn/H₂O gives di-carbonyl compound.

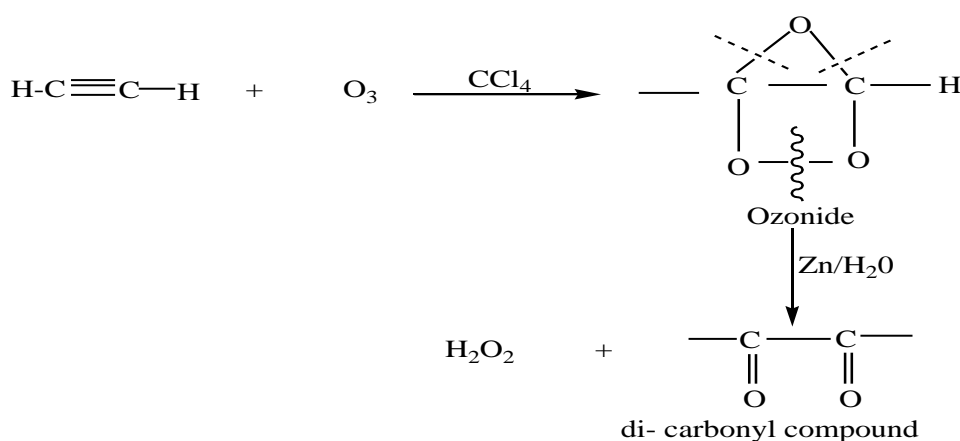

10.8 SUMMARY

- Alkynes contain the doubly unsaturated $C\equiv C$ functional group. Terminal alkynes, $R-C\equiv C-H$, are quite acidic for hydrocarbons and can be deprotonated to form a carbanion that can then be alkylated. Like alkenes ($C=C$), the alkyne $C\equiv C$ undergoes a variety of addition reactions.
- Summary of the Key reaction of Alkynes.

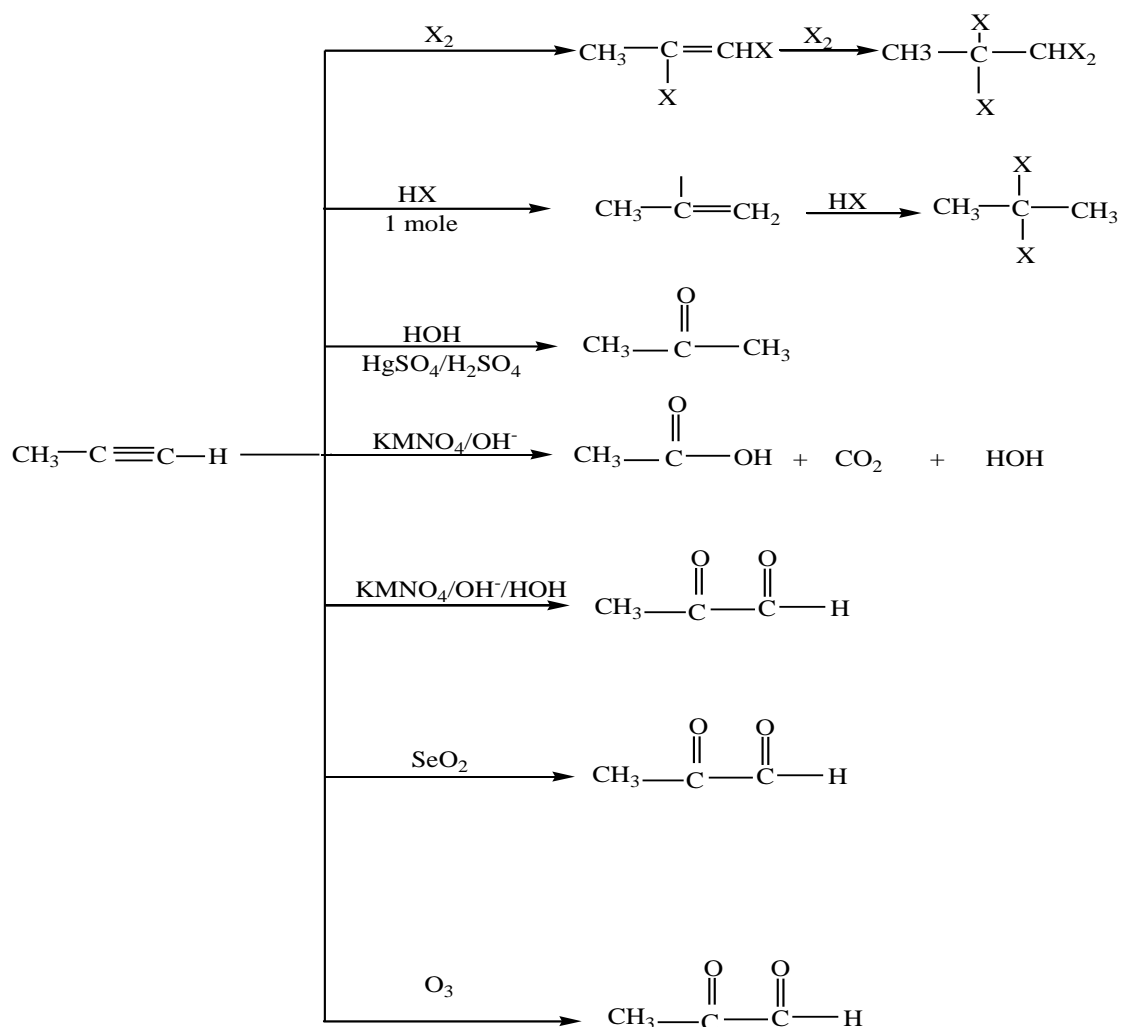

10.9 TERMINAL QUESTION

Q.1 Explain why?

- Alkynes do not exhibit geometrical isomerism while alkenes do so why?
- Alkynes are less reactive than alkenes towards electrophilic addition reaction why?
- Why does acetylene behave like a weak acid?
- Alkynes undergo both electrophilic and nucleophilic addition reactions. Why?

Q.2 Discuss structure of alkyne.

Q.3 Give mechanism of addition of halogens to alkynes.

Q.4 How will you distinguish between Ethene and Ethyne? Give reaction.

10.10 BIOLIOGRAPHY

1. Advanced Organic Chemistry by, Jagdamba Singh and L.D.S. Yadav, Pragati Prakashana.
2. Paula Yurkanis Bruice 4th edition.
3. Organic Reactions and Their Mechanisms, by P. S. Kalsi, New edge Science.
4. R. L. Madan, S. Chand and company Pvt. Ltd.

UNIT 11: STATE OF THE MATTER-I

CONTENTS

- 11.1 Introduction
- 11.2 Objective
- 11.3 Distribution of Molecular velocities
- 11.4 Different kind of velocitie
- 11.5 Qualitative discussion of Maxwell's distribution of velocities
- 11.6 Collision number/collision diameter
- 11.7 Collision frequency
- 11.8 Mean free path
- 11.9 Liquification of gases
- 11.10 Joule-Thomson's Effect
- 11.11 Intermolecular forces
- 11.12 Structure of liquids
- 11.13 Characteristic properties of liquids
- 11.14 Refractive Index
- 11.15 Liquid Crystals:
- 11.16 Structure of liquid crystals
- 11. 17 Summary
- 11.18 References
- 11.19 Terminal Questions

11.1 INTRODUCTION

Though gas molecules possess very high velocity and because of collisions the velocity of gas molecules changes in a very short span but velocity can be easily calculated from kinetic gas equation. In this unit you will study different types of velocities their correlation and calculation, collision diameter, collision number, free path and various methods of liquefaction of gases will be discussed in this chapter. It will also be very interesting to study how molecular velocities are distributed i.e. Maxwell's equation for distribution of velocities. Liquids can be obtained from gases by cooling the latter below their respective critical temperature followed by the treatment of high pressure. Effect of cooling is to decrease the thermal energies of molecules and the effect of pressure is to decrease the volume of the system so as to allow the molecules to come closer, thereby increasing the force of attraction amongst them. Alternatively, liquids can be obtained by heating solids upto or beyond their melting points. Thus we see the properties of liquids lie in between those of solids and gases. For example liquids are less compressible than gases but a little more compressible than solids. They are less dense than solid but more dense than gases. The two important properties of liquids, namely, the fixed volume but no fixed shape arises mainly because of the following two facts

- (1) The energies binding the molecules are larger than their average thermal energy.
- (2) Their binding energies are not strong enough to stop the motion of the molecules altogether, as in the case of solids, with the result that molecules can move from one place to another but cannot escape from the liquid unless they are present at the surface.

11.2 OBJECTIVES

In this unit you are able to know about the :

- Till now you have studied the various postulates of kinetic theory of gases, the kinetic gas equation and derivation of various gas laws by making use of kinetic gas equation.
- Though the kinetic gas equation is useful in deriving the gas law but at high pressure and at low temperature there are considerable deviations from ideal gas behaviour.
- These derivations have been explained by Van der Waal and the Van der Waal's equation explains the deviations by applying pressure and volume corrections.

- The law of corresponding state and its consequences have been discussed in this chapter. The matter exists in three states. The solid state in crystalline form exhibits a complete orderly arrangement of molecules atoms or ions as the case may be.
- The gaseous state exhibits complete disorder or randomness. The liquid state lies in between these two extreme order and disorder.
- The definite and ordered arrangement of the constituents of a solid extends over a large distance. This is termed as long range order. The liquids exhibit only a short range order while gases show no order at all.
- A liquid may be regarded as a condensed gas or molten solid. In a solid the molecules are rigidly fixed and, therefore, it has a definite shape and a definite volume. In a gas, on the other hand the molecules have random motion and, therefore, it has neither a definite shape nor a definite volume. In a liquid the molecules are not as rigidly fixed as in solids.
- They have some freedom of motion which, however, is much more restricted than that in gases. A liquid, therefore has a definite volume although not a definite shape. It is much less compressible and are far denser than gases.

11.3 DISTRIBUTION OF MOLECULAR VELOCITIES

All the molecules constituting a given quantity of any gas do not possess the same velocity. Even a single molecule cannot maintain the same velocity for any length of time. As it collides with another molecule the kinetic energies and the velocities of two are redistributed and a consequence change in velocity takes place. In fact the velocity of a molecule changes after a span of less than 10^{-9} seconds, thus making it difficult to know the speed of a single molecule. Since number of molecule is very large, a fraction of molecule will have the same particular velocity. In this way there is a broad distribution of velocities over different fraction of molecules. In 1860 James Clark Maxwell calculated the distribution of velocities from the laws of probability. He derived the following equation for the distribution of molecular velocities.

$$\frac{dN_c}{N} = 4\pi\left(\frac{M}{2\pi RT}\right)^{3/2} e^{-\frac{Mc^2}{2RT}} c^2 dc \quad \dots\dots(1)$$

Where dN_c = number of molecules having velocities between c and $(c+dc)$

N = total number of molecules

M = molar mass

T = temperature in absolute scale.

This relation is called Maxwell's law of distribution of velocities. The ratio dN_c/n gives the fraction of the total number of molecules having velocities between c and $(c+dc)$.

Maxwell plotted such fractions against velocity possessed by the molecules. The curve so obtained illustrate the salient features of Maxwell distribution of velocities. Fig 11.1 shows the distribution of velocities in nitrogen gas, N_2 at 300K and 600K. It is noticed that:

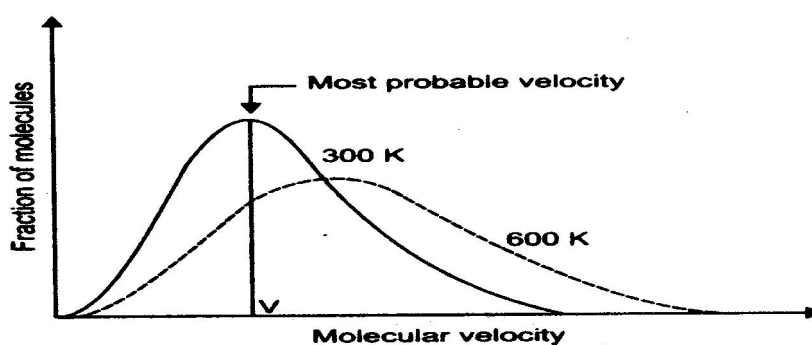

Fig 11.1 Distribution of molecular velocities at two temperatures.

1. A very small fraction of molecules has either very low (close to zero) or very high velocities (i.e. velocity greater than a high value).
2. A large majority of the molecules have a velocity in a relatively small range of variation more or less around the peak of the curve.

The velocity represented by maximum number of molecules of a gas at a given temperature is called most probable velocity. This corresponds to the highest point on the curve.

3. At higher temperature, the whole curve shifts to the right (dotted curve at 600K). This shows that at higher temperature more molecules have higher velocities and fewer molecules have lower velocities.

11.4 DIFFERENT KIND OF VELOCITIES

11.4.1 Root mean square velocity: Velocity v which is possessed by each of the n molecules of the gas leads to correct calculation of total kinetic energy of the gas is known as root mean square velocity.

$$\text{Total kinetic energy} = n \frac{1}{2} m v^2 \quad \dots\dots(2)$$

We will proceed to test the validity of the above equation (2) mathematically.

Out of the total number of molecules n contained in the given sample of gas, let n_1 , n_2 molecules have velocity v_1 , n_2 molecules have velocity v_2 and so on then,

$$n = n_1 + n_2 + n_3 \quad \dots\dots\dots(3)$$

the total kinetic energy KE of the n molecules is the sum of the kinetic energies of the individual molecules.

Thus

$$KE = n_1 \times \frac{1}{2} m_1 v_1^2 + n_2 \times \frac{1}{2} m_2 v_2^2 + \dots\dots$$

$$\frac{1}{2} n v^2 = n_1 \times \frac{1}{2} m_1 v_1^2 + n_2 \times \frac{1}{2} m_2 v_2^2 + \dots\dots \quad \dots\dots(4)$$

$$n v^2 = n_1 v_1^2 + n_2 v_2^2 + \dots\dots \quad \dots\dots (5)$$

$$v^2 = \frac{n_1 v_1^2 + n_2 v_2^2 + \dots\dots}{n} \quad \dots\dots\dots(6)$$

thus v^2 is the mean of squares of the velocities of all the n molecules in the gas and is termed as mean square velocity.

$$\text{so } v = \sqrt{\frac{n_1 v_1^2 + n_2 v_2^2 + \dots\dots}{n}} \quad \dots\dots\dots(7)$$

Here v is root of the mean of squares of velocities and is called root mean square velocity and is often written simply as rms velocity. Its value can be calculated as

$$v_{\text{rms}} = \sqrt{\frac{3RT}{M}} \quad \dots\dots\dots(8)$$

11.4.2 Average velocity

The average velocity is given by the arithmetic mean of different velocities possessed by the molecules of the gas at a given temperature.

Suppose one molecule is moving with velocity v_1 , one molecule with velocity v_2 , third molecule with velocity v_3 and so on. Then total velocity will be

$$v_1 + v_2 + v_3 \dots\dots\dots$$

There are total of n molecules

$$\text{The } v_a = \frac{v_1 + v_2 + v_3 \dots\dots\dots}{n}$$

its value can be calculated as $v_a = \left(\frac{2RT}{M}\right)^{1/2}$ (9)

This is average velocity represented by v_a

11.4.3 Most probable velocity

Velocity possessed by most number of molecules is known as most probable velocity. (Fig 3.1)

Most probable velocity

$$v_{mp} = (8RT/\pi M)^{1/2} \dots\dots(10)$$

It is found that

$$v_{rms} > v_a > v_{mp}$$

$$v_{rms} : v_a : v_{mp} = 1.0 : 0.92 : 0.82$$

11.5 QUALITATIVE DISCUSSION OF MAXWELL'S DISTRIBUTION OF VELOCITIES

Though molecules of the gas moves with very high velocity and the velocity changes because of collisions with in very short time span, but with the help of Maxwell's distribution

law and molecular kinetic energy molecular velocity can be calculated. It will be clear to you when you study numerical problems.

11.5.1 Effect of temperature on velocity distribution

It is clear from fig 3.1 that the velocity distribution of molecules in gas is influenced by a rise in temperature. At a higher temperature (600K) the curve maintains the same general trend of distribution. However, it becomes more flattened with the peak shifting to a higher velocity region. In other words, there is more even distribution of velocities about 'most probable velocity' and the number of molecules having velocities near this value becomes more. Thus higher the temperature, higher is the most probable velocity.

11.6 COLLISION NUMBER/COLLISION DIAMETER

The kinetic theory of gases treats molecule as point masses. When two such molecules approach each other, a point is reached at which they cannot come closer beyond a certain distance.

The closest distance between the centres of the two molecules taking part in collision is called the collision diameter. It is denoted by σ .

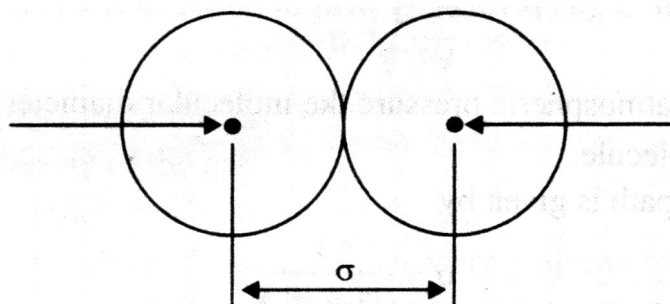

Fig 11.2

Whenever the distance between the centres of two molecules is σ , a collision occurs. The collision diameter can be determined from viscosity measurements. The collision diameter of hydrogen is 2.74\AA and that of oxygen is 3.61\AA .

11.7 COLLISION FREQUENCY

The collision frequency of a gas is defined as:

The number of collisions taking place per second per unit volume (c.c.) of the gas.

Let a gas contain N molecules per cc. From kinetic considerations it has been established that the number of molecules, n , with which a simple molecule will collide per second, is given by the relation

$$n = \sqrt{2\pi} v_a \sigma^2 N \quad \dots\dots(11)$$

where v_a = average velocity and σ = collision diameter.

If the total number of collisions taking place per second is denoted by z we have

$$\begin{aligned} z &= \sqrt{2\pi} v_a \sigma^2 N \times N \\ &= \sqrt{2\pi} v_a \sigma^2 N^2 \quad \dots\dots(12) \end{aligned}$$

Since each collision involves two molecules, the number of collision per second per cc, of the gas will be $z/2$

$$\begin{aligned} \text{Hence the collision frequency} &= \frac{\sqrt{2\pi} v_a \sigma^2 N^2}{2} \\ &= \frac{\pi v_a \sigma^2 N^2}{\sqrt{2}} \quad \dots\dots(13) \end{aligned}$$

Evidently, the collision frequency of a gas increases with increase in temperature, molecular size and the number of molecules per c.c.

11.7.1 Effect of temperature on collision frequency

We know collision frequency is given by

$$z = \frac{\pi v_a \sigma^2 N^2}{\sqrt{2}} \quad \dots\dots(14)$$

From the equation it is clear

$$z \propto v_a$$

But $v_a \propto \sqrt{T}$ (from equation 9)

Hence $z \propto \sqrt{T}$

Hence collision frequency is directly proportional to square root of temperature.

11.7.2 Effect of pressure on collision frequency

From equation (14)

$$z \propto N^2$$

Where N is number of molecules per cc.

But we know $P \propto N$

Hence $z \propto P^2$

Thus collision frequency is directly proportional to the square of pressure of the gas.

11.8 MEAN FREE PATH

A very important quantity in kinetic theory of gases is the mean free path. At a given temperature, a molecule travels in straight line before collision with another molecule.

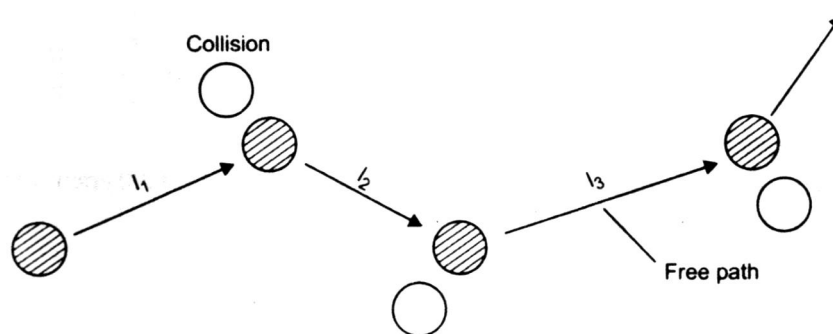

Fig 11.3 Mean free path

The distance travelled by the molecule before collision is termed free path. The mean distance travelled by a gas molecule between two successive collisions is called the mean free path. It is denoted by λ . If l_1, l_2, l_3 are the free paths for a molecule of a gas, its free path

$$\lambda = \frac{l_1 + l_2 + l_3 + \dots + l_n}{n} \quad \dots \dots \dots (15)$$

n

Where n is number of molecules with which the molecule collides. Evidently, the molecular collisions will be less at a lower pressure or lower density and longer will be the mean free path. Mean free path is also related with viscosity of the gas.

$$\lambda = \frac{\eta \sqrt{3}}{P_d}$$

where p = pressure of the gas

η = coefficient of viscosity of the gas

d = density of the gas

From the above equation it is clear that by the determination of viscosity mean per path can be calculated. At NTP the mean free path for hydrogen is 1.78×10^{-5} cm and for oxygen 1.0×10^{-5} cm.

11.8.1 Effect of temperature on mean free path

The ideal gas equation is $PV = nRT$ (16)

Where n is number of moles given by

$$n = \text{No of molecules} / \text{Avogadro's number} = N/N_0$$

Substituting the value of n in equation (16)

$$PV = N/N_0 \times RT$$

$$\text{or } N/V = (PN_0)/RT$$

$$\text{At constant pressure} \quad N \propto \frac{1}{T} \quad \text{.....(17)}$$

The mean free path is given by

$$\begin{aligned} \lambda &= \text{Distance Travelled by the molecule per second} / \text{Number of collisions per cc} \\ &= \frac{v}{\sqrt{2} \pi \sigma^2 v N} \quad \text{.....(18)} \end{aligned}$$

Combining equation (17) and equation 18

$$\lambda \propto T$$

Thus mean free path is directly proportional to the absolute temperature.

11.8.2 Effect of pressure on mean free path

We know that the pressure of a gas at certain temperature is directly proportional to the number of molecules cc. that is,

$$P \propto N$$

and mean free path is $\lambda = 1/\sqrt{2}\pi\sigma^2N$

Hence we get

$$\lambda \propto 1/P$$

Thus mean free path is inversely proportional to the pressure of a gas at constant temperature.

11.9 LIQUIFICATION OF GASES

The general behaviour of gases with the decrease of temperature with increase of pressure is shown by the Andrew isotherm of carbon dioxide. You have studied these in chapter 2.3.3 and shown in fig 2.10.

It is clear from Andrews isotherm, it is necessary to cool a gas below its critical temperature before it can be liquified. In the case of gases like ammonia, Chlorine, sulphur dioxide or carbon dioxide, which has a fairly high critical temperature (table 3.1), by the application of pressure gas can be liquified.

Gas	Critical temperature (K)
He	5.2
Ne	44.2
H ₂	33.0
O ₂	154.8
N ₂	126.2
CO ₂	304.2
NH ₃	405.0

Table 3.1 Critical temperature of various gases

Gases such as hydrogen, oxygen, helium and nitrogen have low critical temperature. So these gases cannot be liquified by this simple technique. These gases can be liquified if they first cooled below these respective critical temperature.

Two principles are usually applied in cooling gases below these critical temperature.

11.10 JOULE-THOMSON'S EFFECT

Joule and Thomson observed that when a gas under high pressure is made to expand into a region of low pressure it suffers a fall in temperature. This phenomenon is known as Joule-Thomson effect.

The Joule-Thomson effect offers further support to the view that attractive forces attractive forces do exist between gas molecules. As the gas expands, the molecules fall apart one another. Therefore, work has to be

done in order to overcome the cohesive or attractive forces which tend to hold the molecules together. Thus work is done by the system at the expense of the kinetic energy of the gaseous molecules. Consequently, the kinetic energy decreases and since it is proportional to temperature cooling results.

Experiments have shown that gases become cooler during the Joule-Thomson expansion only when they are below a certain temperature known as inversion temperature T_i . The inversion temperature is characteristic of each gas. The inversion temperature is related to von der Waals constants a and b of the gas concerned by the expression

$$T_i = 2a/Rb$$

At the inversion temperature there is no Joule-Thomson effect. If the temperature is above inversion temperature then after passing into lower pressure region there will be rise of temperature and if it takes place below the inversion temperature there is fall of temperature.

In most gases, the inversion temperature lies within the range of ordinary temperatures. Hence they get cooled in Joule-Thomson expansion. Hydrogen and helium, however, have very low inversion temperature. Thus at ordinary temperatures these gases get warmed up instead of getting cooled at the Joule-Thomson expansion. If these gases are first cooled to their respective inversion temperatures, then these gases also get cooled on expansion in accordance with the Joule-Thomson effect.

Adiabatic expansion involving mechanical work:

When a gas is made to expand against pressure it does some work as in the case of an engine, it does some external work also at the expense of its kinetic energy which decreases. Hence, there is a fall of temperature.

11.10.1 Methods of liquefaction

From the above discussion it is clear to you that two conditions which tend to change a gas into the liquid state are low temperature and high pressure. If a gas is cooled below its critical temperature and subjected to adequate pressure, it liquefies. The various methods employed for the liquification of gases depend on the technique used to attain low temperature. The three important methods are

- (i) Faraday's method in which cooling is done with a freezing mixture.
- (ii) Linde's method in which compressed gas is released at a narrow jet (Joule-Thomson effect).
- (iii) Claude's method in which gas is allowed to do mechanical work.

11.10.2 Faraday's method- Faraday (1823) used freezing mixture of ice with various salts for external cooling of gases.

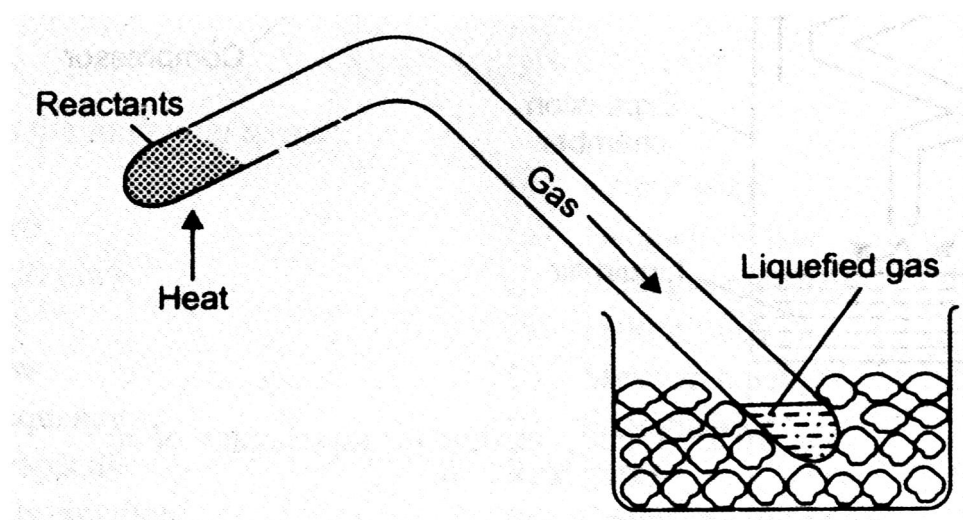

Fig 11.4 Faraday's method for the liquefaction of gases

The melting of ice and dissolution of salts both are endothermic processes. The temperature of the mixture is lowered up to a temperature when the solution becomes saturated.

Faraday succeeded in liquefying a number of gases such as SO_2 , CO_2 , NO , Cl_2 by this method. He used V-shaped tube in one arm of which gas was prepared. In the other arm the gas was liquefied under its own pressure.

The gases liquefied by this method had their critical temperature above or just below the ordinary atmospheric temperature. The gases like N_2 , O_2 and H_2 having low critical points could not be liquefied by this method.

11.10.3 Linde's method

Linde's (1895) used Joule-Thomson effect as the basis for liquefaction of gases. When a compressed gas is allowed to expand into vacuum or a region of low pressure, it produces intense cooling.

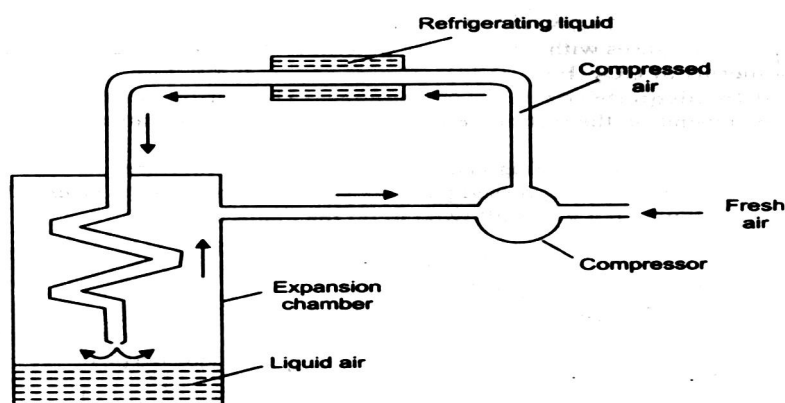

Fig 11.5 Linde's method for liquefaction of air

In a compressed gas molecules are very close and attraction between them are appreciable. As the gas expands, the molecules move apart. In doing so, the intermolecular attraction must be overcome. The energy for it is taken from the gas itself which is thereby cooled.

Linde used an apparatus worked on the above principle to the liquefaction of air as shown in **Fig 11.5**. Pure dry air is compressed to about 200 atmospheres. It is passed through a pipe cooled by a refrigerating liquid such as ammonia. By doing this the heat of compression is removed. The compressed air is then passed into a spiral pipe with a jet at the lower end. The free expansions of air at the jet result in a considerable drop of temperature. The cooled air which is now at about one atmosphere pressure passed up the expansion chamber. It further cools the incoming air of the spiral tube and returns to the compressor. By

repeating the process of compression and expansion a temperature low enough to liquefy air is reached. The liquefied air collects at the bottom of the expansion chamber.

11.10.4 Claude's method

In this method the compressed air is allowed to do mechanical work by driving an engine.

The energy for it comes from the gas itself.

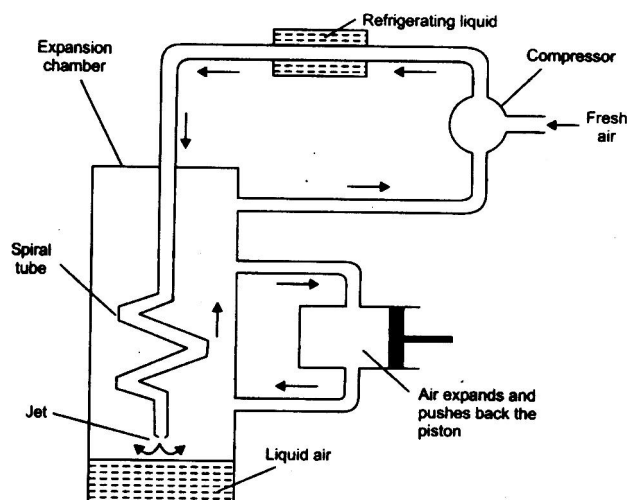

Fig 11.6 Claude's method for liquefaction of air

Thus in Claude's method the gas is cooled not only by overcoming the intermolecular forces but also by performance of work. That is why the cooling produced greater than in Linde's method.

Claude's apparatus is shown in fig 11.6 for liquefaction of air. Dry air is compressed to about 200 atmospheres. It is passed through a tube cooled by refrigerating liquid to remove any heat produced during compression. The tube carrying the compressed air then enters the expansion chamber. At this stage it bifurcates and a part of this air passes through a side tube into the cylinder of an engine. Here it expands and pushes back the piston. Now it is clear that the air does mechanical work and it cools. The air then enters the expansion chamber and cools the incoming air through the spiral tube. The air undergoes further cooling by expansion at the jet and liquefies. The gas escaping liquefaction goes back to the compressor and the whole process is repeated over and over again.

Paramagnetic cooling:

It was shown by Debye on theoretical grounds that a very close approach to absolute zero was possible by adiabatic demagnetisation of a paramagnetic salt. When a paramagnetic substance is magnetised, external work is done by it and its temperature rises. But when it is demagnetised external work is done by it and its temperature falls. In this method a temperature of the order of 0.002K has been attained.

11.11 INTERMOLECULAR FORCES

Since the molecules in a liquid are not far apart from each other, the intermolecular forces are fairly strong. The characteristic properties of liquid arise from the nature and the magnitude of these intermolecular forces.

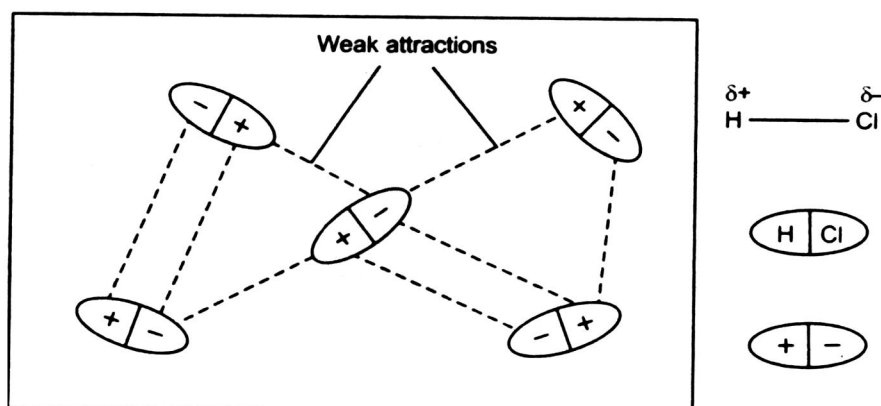

Fig 11.7 Weak attraction between polar HCl molecules

Intermolecular forces in liquids are collectively called von der Waal's forces. These forces are essentially electrical in nature and result from the attraction of charges of opposite sign. The principle kinds of intermolecular forces are:

- (i) Dipole-dipole interaction
- (ii) London forces
- (iii) Hydrogen bonding.

11.11.1 Dipole-dipole interaction

We have seen that HCl is an example of a polar molecule. Such molecule have a partial positive charge at one end and a partial negative charge at the other.

They are called dipoles. The positive end of one dipole attracts the negative end of the other. The thermal energy of molecules tends to disturb these attractions but still there exists a net attraction between the polar molecules. These forces are referred to as dipole-dipole attractions. Generally such attractions are about 1% as strong as covalent bond. It is to be noted that the attractions between the opposite poles are greater than repulsive forces between like poles. Thus these molecules have a net attraction to each other.

11.11.2 London forces

In 1930 Fritz London first offered a simple explanation of weak forces between nonpolar molecules or atoms. In a molecule (or atom) electrons are constantly moving. Most of the time electrons in the molecules could not be visualized as distributed symmetrically. However according to the principle of probability, for an instant the electrons may concentrate on one side of the molecule than the other. This causes the molecule (A) to become momentarily polar and we call it instant dipole.

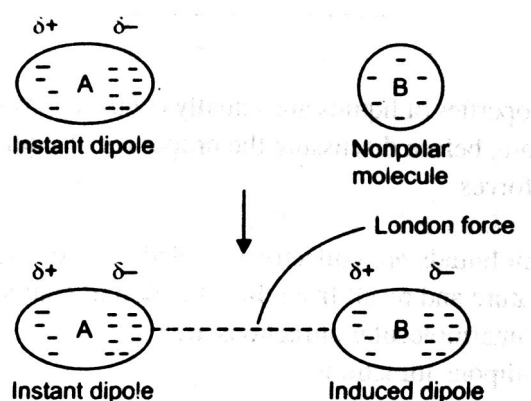

fig 11.8 Explanation of London forces

The negative side of the instantaneous dipole repels the electrons of an adjacent molecule (B). As a result the second molecule B also becomes a dipole by induced polarity. This is called induced dipole **Fig 11.8**.

The instantaneous dipole A and the induced dipole B will now attract each other. Because the electrons keep moving an instant dipole may vanish the next moment and new

are produced. This continual process produces a weak overall attraction between molecules of liquid.

The momentary attraction between the molecules of liquid caused by instantaneous-dipole and **induced-dipole attractions are called London forces**. These London forces are present in polar molecules also in addition to other von der Waal's forces.

The strength of the London forces depends as to how easily the electron cloud in a particular molecule is deformed. This is determined by the number of electrons and also on the size of the molecule. Thus Argon (-245.9°C) with a greater number of electron and larger molecular weight has a higher boiling point than helium (-268.9°C)

11.11. 3 Hydrogen bonding

In compounds of hydrogen with strongly electronegative elements, such as fluorine, oxygen and nitrogen, the electron pair shared between the two atoms lies far away from the hydrogen atom as a result of which the hydrogen atom becomes highly electropositive with

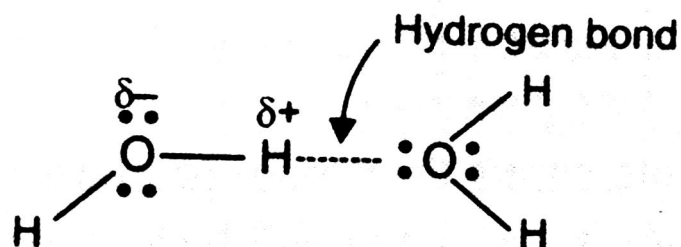
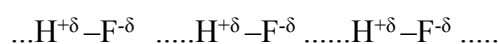

Fig 11.9 Hydrogen bond

respect to other atom which become electronegative. This phenomenon of charge separation in water is represented as shown in the fig 11.9. The electronegativity difference in H and O is so large that the electron pair in the covalent bond, H-O is shifted toward O. It leaves a partial positive charge on the H atom. This leads to a strong electrostatic attraction between positively charged H atom and an unshared electron pair on the O atom of another molecule. Thus you can understand that two or more molecules may associate together to form large cluster of molecule. This is shown below for the association of several molecules of hydrogen fluoride.



In this case, while the length of covalent bond between H and F atoms is found to be 1.00\AA , the length of the hydrogen bond between H and F atoms of neighbouring molecules has been found to be 1.55\AA . this cluster of HF molecules may be described as $(\text{HF})_n$

The attractive force which binds hydrogen atom of one molecule with electronegative atom of another molecule, generally of the same substance is known as the hydrogen bond.

The hydrogen bonding is the strongest of all intermolecular forces including the dipole-dipole attractions and London forces.

In the above discussion you have seen that cluster of HF molecule is described as $(\text{HF})_n$ and cluster of water molecule may be described as $(\text{H}_2\text{O})_n$

Alcohols and carboxylic acids also form associated molecules for the same reason, as shown below

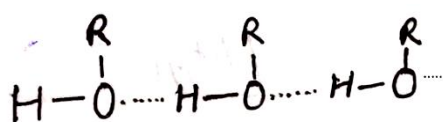

Alcohols

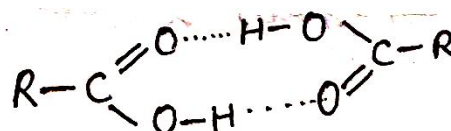

Carboxylic Acids

11.12 STRUCTURE OF LIQUIDS

In a liquid, the molecules are not as rigidly fixed as in a solid. They have some freedom of motion which, however, is much less than that in a gas. Liquids resemble solids in being compact, incompressible and in having a definite volume. These properties are indicative of a regular structure in liquids similar to that in solids.

From X-ray diffraction technique, it has been found that the resemblance of liquid state with solid state is valid within a small range; i.e. within only a small distance from a given molecule. In other words the regularly ordered structure which exists in crystalline solids is of short range in liquids. It means it exists only within a short distance from any given molecule. A solid possesses short range as well as long range order since the ordered structure extends regularly throughout the whole crystal.

Now it should be clear to you that

- (i) A gas consists of molecules separated wide apart in empty space. The molecules are free to move about throughout the container.
- (ii) A liquid has molecule touching each other. However, the intermolecular space, permit the movement of molecule throughout the liquid.
- (iii) A solid has molecules, atoms or ions arranged in a certain order in fixed position in the crystal lattice. The particles in a solid are not free to move about but vibrate in their fixed position.

11.13 CHARACTERISTIC PROPERTIES OF LIQUIDS

As you have studied earlier in this unit that the properties of liquids arise from

- (i) The nature and
- (ii) The magnitude of intermolecular forces of attraction existing between their molecules.

The important properties of liquids are :

1. Vapour pressure
2. Surface tension
3. Viscosity
4. Refraction

Now you will study these properties in detail

11.13.1 Vapour pressure

When a liquid is in an open vessel, it evaporates. You have studied in the gases unit, that the gas molecules have a particular velocity. This is so in case of liquids also. Only a few liquid molecules have lower or higher velocity, i.e. lower or higher kinetic energies. The energy distribution of molecules in a liquid is shown in Fig 11.10

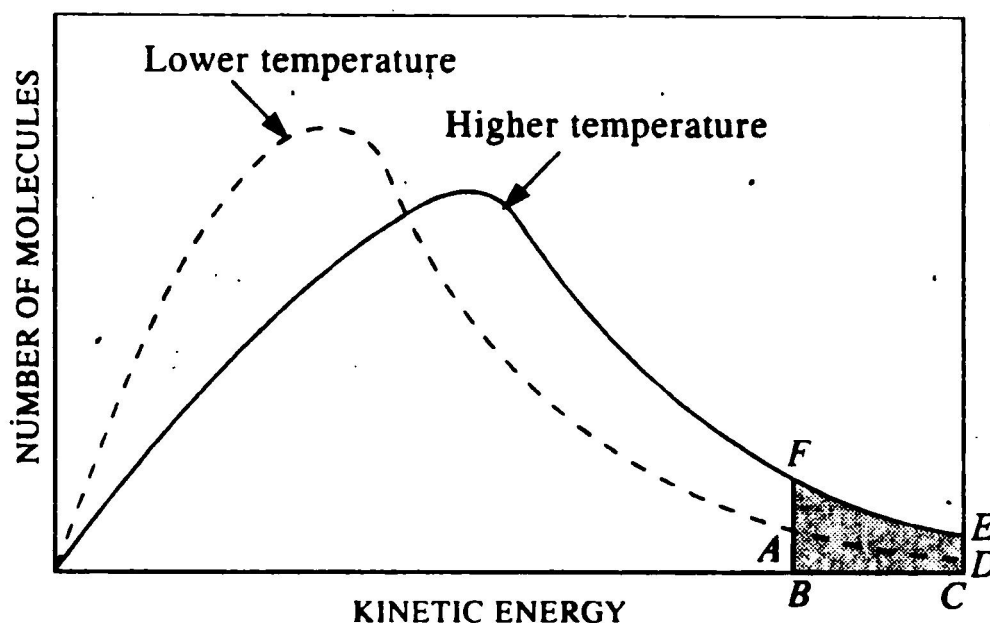

Fig 11.10 energy distribution of molecules of a liquid

It is clear from the **Fig 11.10** that the number of molecules with high kinetic energies, as shown by the shaded portion ABCD of the dotted curve is very small. This number, however, increases with rise in temperature, as shown by the shaded portion FBCE of the bold line curve.

When a liquid is placed in an open vessel it evaporates. The molecules in the liquid are moving with different kinetic energies. The molecules that possess above average kinetic energies can overcome the intermolecular forces that hold them in the liquid. These energetic molecules escape from the surface as vapour. This process by which molecules of a liquid go into gaseous state is called vaporisation or evaporation. The reverse process whereby gas molecules become liquid is called condensation.

When a liquid is placed in a closed vessel, the molecules with high kinetic energies escape into space above the liquid as shown in fig 4.5. as the number of molecules in the gas phase increases, some of them strike the liquid surface and are recaptured (condensation).

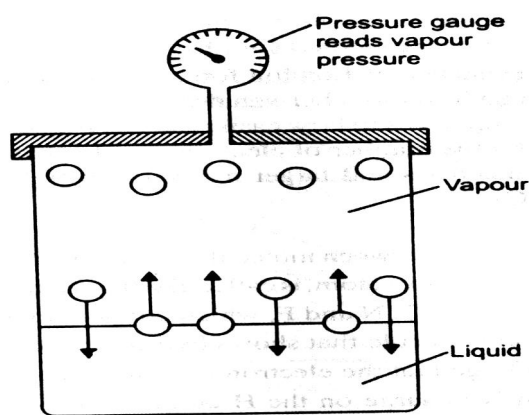
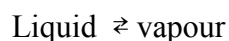

Fig 11.11 Illustration of vapour pressure

A stage comes when the number of molecules escaping from the liquid is equal to the number of molecules returning to the liquid. Thus a dynamic equilibrium is established between the liquid and the vapour at a given temperature.



Now the concentration of the vapour in the space above the liquid will remain unchanged with lapse of time. Hence the vapour will exert a definite pressure at the equilibrium. Hence vapour pressure of a liquid defined as: **The pressure exerted by the vapour in equilibrium with the liquid at a fixed temperature is the vapour pressure of the liquid.** As the temperature rises, the number of molecules escaping from the liquid surface increases as there is an increase in the number of vapour molecules in the space above the liquid when equilibrium is attained.

Hence vapour pressure of the liquid increases with increase of temperature.

11.13.1.1 Determination of vapour pressure

(a) Static method:

A simple apparatus used in this method is shown in fig 4.6. A sufficient amount of the liquid whose vapour pressure is to be determined is placed in the bulb connected to a mercury manometer and a vacuum pump.

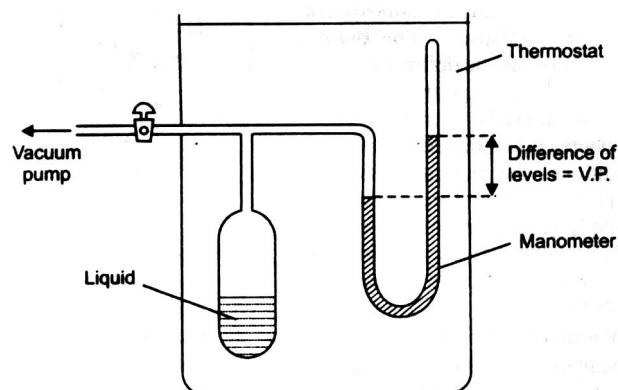

Fig 11.12 Determination of vapour pressure by static method

All the air from the bulb is removed by working the vacuum pump and the stopcock closed. A part of liquid evaporates. The system is then maintained at a fixed temperature for enough time so that equilibrium is attained. The difference in the levels of mercury in the manometer is equal to vapour pressure of the liquid. This method is used for liquids having vapour pressure up to one atmosphere.

(b) Dynamic method:

The apparatus used for the dynamic method is shown in fig 4.7.

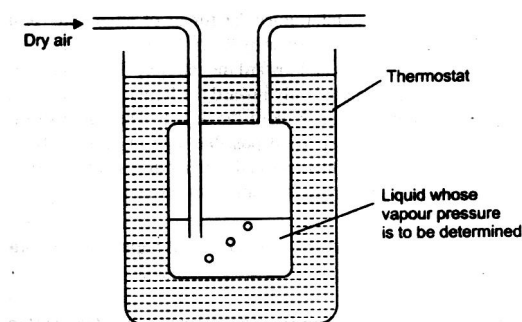

Fig.11.13 Dynamic method

An inert gas is passed through the given liquid at a constant temperature (T). The gas saturated with the vapour of the liquid leaves the flask at the exit tube. If V is the volume of the gas passed and m the loss in weight of the liquid the vapour pressure is given by the expression.

$$\text{Vapour pressure} = \frac{m}{MV} RT$$

Where M is the molecular weight of the liquid and R the gas constant. This method is particularly useful for liquids of very low vapour pressure

11.13.2 Surface tension

The existence of strong intermolecular forces of attraction in liquids gives rise to a property known as surface tension. The phenomenon of surface tension can be described as follows.

A molecule in the interior of a liquid is attracted equally in all directions by the molecules around it. A molecule in the surface of a liquid is attracted only sideways and towards the interior. The forces on the sides being counterbalanced, the surface is pulled only inward the liquid. These unbalanced attractive forces acting downward tend to draw the surface molecules into the body of the liquid and, therefore, tend to reduce the surface to minimum. The liquid then behaves as if it were under a strain or tension. It is this force which is called surface tension. It may be defined as **“the force in dynes acting on the surface of the liquid at right angles to one centimetre length of the surface”**. It is represented by a symbol γ (gama).

In CGS system the unit of surface tension is dynes per centimetre (dyne cm^{-1}). In SI system, the unit is Newton per metre (Nm^{-1}). Both these units are related as follows

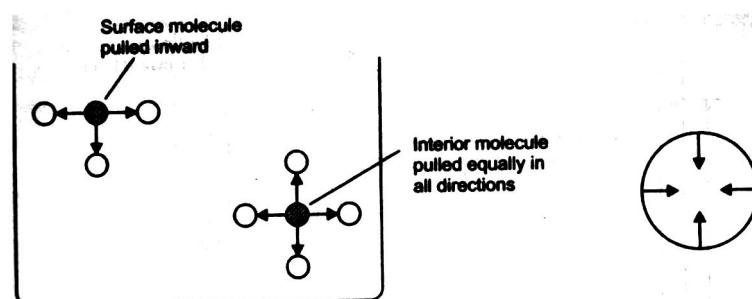

Fig. 11.14 molecular attractions

$$\text{Surface energy} = \frac{\text{amount of work done}}{\text{amount of area extended}} = \frac{\text{force} \times \text{distance}}{\text{area}}$$

Hence in CGS units we have

$$\text{Surface energy} = \frac{\text{dyn} \times \text{cm}}{\text{cm}^2} = \text{dyn} \times \text{cm}^{-1} = \text{surface tension}$$

In SI units we have

$$\text{Surface energy} = \frac{\text{N} \times \text{m}}{\text{m}^2} = \text{Nm}^{-1}$$

obviously,

$$1 \text{ dyne cm}^{-1} = (10^{-5}\text{N}) (10^{-2}\text{m})^{-1} \\ = 10^{-3}\text{Nm}^{-1}$$

11.13.2.1 Effect of temperature on surface tension

When temperature increases, there is increase in kinetic energy of liquid molecules ($KE \propto T$) thereby decreasing intermolecular forces. It results in decrease in inward pull functioning on the surface of the liquid. That means you can say surface tension decreases with increase in temperature. As surface tension arises of the attractive forces operating between the molecules, Ramsay and Shields gave the following relationship between the surface tension of a liquid and its temperature.

$$\gamma(M/d)^{2/3} = k(t_c - t - \theta)$$

where k is constant

t_c is critical temperature and t any other temperature $\gamma (M/d)^{2/3}$ represents molar surface energy of liquid.

11.13.2.2 Determination of surface tension

(i) Capillary rise method:

In this method a capillary tube of radius r is vertically inserted into the liquid. The liquid rises to a height h and form a concave meniscus.

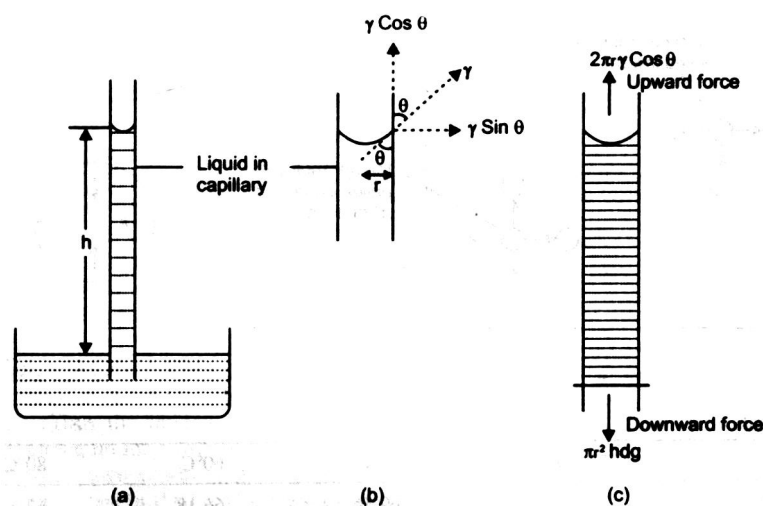

Fig 11.15 capillary rise method of surface tension

The surface tension γ acting in the inner circumference of the tube exactly supports the weight of the liquid column. By definition, surface tension is force per 1 cm acting at a tangent to the meniscus surface. If the angle between the tangent and the tube wall is θ , the

vertical component of surface tension is $\gamma \cos\theta$. The total surface tension along the circular contact line of meniscus is $2\pi r$ times.

Therefore upward force = $2\pi r\gamma \cos\theta$

Where r is radius of capillary. For most liquids, θ is essentially zero, and $\cos\theta=1$ then the upward force reduces to $2\pi r\gamma$

The downward force on the liquid column is due to its weight which is mass \times g , thus downward force is $h\pi r^2 dg$, where d is density of the liquid

Now upward force = downward force

$$2\pi r\gamma = h\pi r^2 dg$$

$$\gamma = hrdg/2 \text{ dynes/cm}$$

once r , h and d are known γ can be calculated.

(ii) Drop weight/ number method:

When a liquid is allowed to flow very slowly through a capillary tube a drop will form which will increase upto a certain point and then fall. If the radius of the end of the tube be r , the total surface tension supporting the drop will be $\gamma 2\pi r$. The drop falls down when its weight W is just equal to this force. Hence we have

$$\gamma 2\pi r = W = mg$$

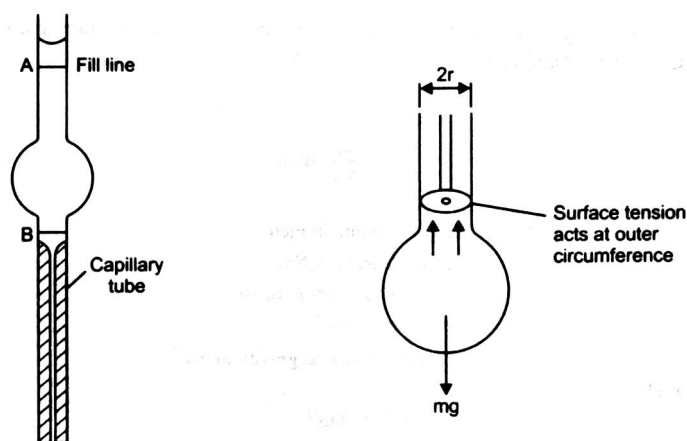

Fig. 11.16 determination of surface tension by drop-pipette

The apparatus employed is a glass pipette with a capillary at the lower part. This is called a drop pipette or stalagmometer. It is cleaned, dried and filled with the experimental liquid, say upto the mark A. (**Fig 11.16**). Then the surface tension is determined by any of the following two methods.

(a) Drop weight method:

About 20 drops of the given liquid are received from the drop-pipette in a weighing bottle and weighed. Thus weight of one drop is found. The drop-pipette is again cleaned and dried. It is filled with the second reference liquid (say water) and weight of one drop is determined as before.

Then we have

$$m_1g = 2\pi r \gamma_1 \text{ and } m_2g = 2\pi r \gamma_2$$

$$\gamma_1/\gamma_2 = \frac{m_1}{m_2}$$

Thus knowing the surface tension of one liquid, the surface tension of other liquid can be found.

(b) Drop number method:

The drop pipette is filled up to the mark A with the liquid whose surface tension is to be determined. The numbers of drops are counted as the meniscus passes from A to B. Similarly the pipette is filled with the reference liquid as the meniscus passes from A to B. Let n_1 and n_2 be the number of drops produced by the same volume V of the two liquids. Thus,

the volume of drop of the experimental liquids = V/n_1

mass of one drop of this liquid = $V/n_1 \times d_1$

where d_1 is its density.

Similarly the mass of one drop of reference liquid = $V/n_2 \times d_2$

Then we have $\gamma_1/\gamma_2 = \frac{(V/n_1)d_1}{(V/n_2)d_2} = \frac{n_2d_1}{n_1d_2}$

The density d_1 can be determined by density bottle, once γ_2 and d_2 are known γ_1 can be calculated.

For most liquids surface tension at room temperature vary between 27 and 42 dynes cm^{-1} . For water however, γ is 72.8 dynes cm^{-1} at 20°C.

This high value is obviously due to strong intermolecular forces which exists in water as a result of extensive hydrogen bonding.

11.13.2.3 Surface tension and chemical constitution

From the study of a large number of liquids, Maclead (1923) showed that

$$\frac{\gamma^{1/4}}{D-d} = C \quad \text{.....(1)}$$

Where γ is surface tension of the liquid, D its density and d density of vapour at the same temperature, C is a constant. Sugden (1924) modified this equation by multiplying both sides by M, the molecular weight of the liquid

$$M \cdot \gamma^{1/4} / D - d = MC = [P] \quad \text{.....(2)}$$

The quantity P, which is a constant for a liquid, was given the name parachor. As d is negligible as compared to D equation (2) reduces to

$$\begin{aligned} M\gamma^{1/4}/D &= [P] \\ \text{or } M/D\gamma^{1/4} &= [P] \\ V\gamma^{1/4} &= [P] \quad \text{.....(3)} \end{aligned}$$

Where γ is molar volume of the liquid. If surface tension γ is unity then $V = [P]$

Thus parachor may be defined as the molar volume of a liquid at a temperature at which its surface tension is unity.

Use of parachor in elucidating molecular structure:

Sugden examined the experimental parachor values of several organic compounds of known molecular structure. He showed that parachor is both additive and constitutive property. That is parachor of an individual compound can be expressed as sum of

- (i) Atomic parachors: which are the contributions of each of the atoms present in the molecule.
- (ii) Structural parachors: which are the contributions of various bonds, rings and other structural factors present in the molecule. By correlating the experimental values of parachor with molecular structure, Sugden (1924) calculated the atomic and structural parameters. These values were further revised by Vogel (1948) on the basis of more accurate measurements of surface tension table 11.2.

Atom	Parachor	Bonder ring	parachor
------	----------	-------------	----------

C	8.6	single bond	0
H	15.7	double bond	19.9
O	20.0	coordinate bond	0
N	12.5	3-member ring	12.3
Cl	55.2	6- member ring	1.4
S	48.2	= CO	44.4

Table 11.2

You will see now that how these values are useful in elucidating molecular structure.

(i) Structure of benzene:

If the Kekule formula for benzene be accepted the parachor value can be calculated by using the data:

6xc	6x8.6	= 51.6
6H	6x15.7	= 94.2
3 =	3x19.9	= 59.7
6 member ring		<u>= 1.4</u>
Total parachor value		= <u>206.9</u>

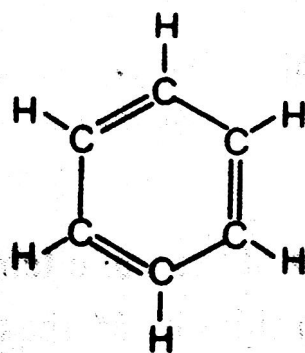

Kekule formula

Fig 11.17

Experimental value of parachor of benzene is 206.2 since the calculated value tallys with that determined by experiment, the Kekule structure for benzene is supported.

(ii) Structure of quinone:

The two possible structural proposed for quinone are

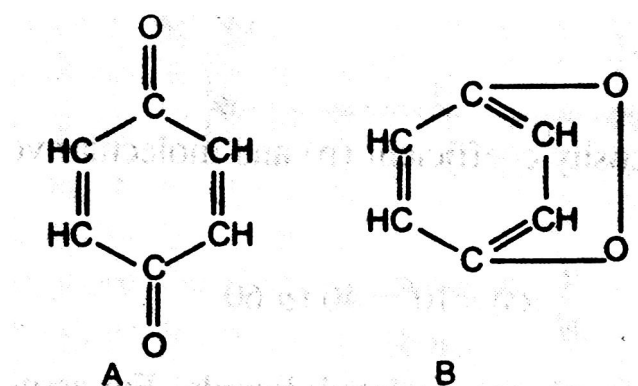

Fig 11.18

The parachor calculated for the two structure are:

Structure A			Structure B		
6C	6x8.6	= 51.6	6C	6x8.6	=51.6
4H	4x15.7	= 62.8	4H	4x15.7	= 62.8
2O	2x19.8	= 39.6	2O	2x19.8	= 39.6
4(=)	4x19.9	= 79.6	3(=)	3x19.9	= 59.7
1 six member ring		= 1.4	2 six member ring		<u>2.8</u>
	Total	235.0		Total	216.5

The observed value for quinone is 236.8 and hence the formula A represents correctly the structure of its molecule.

11.13.3 Viscosity

Some liquids flow more rapidly than others. In other words, liquid molecules pose resistance to the flow of one layer over the other. This property of liquids which determines their flow is termed viscosity. The property of the liquid which determines its flow is called viscosity of the liquid.

The resistance to flow of one layer of liquid molecules over another depends on the following factors.

1. The intermolecular attractive forces do not permit a free flow of molecules in a liquid. The strength of intermolecular forces gives a rough major of the viscosity of the liquids.
2. The molecular weight or mass of the molecules of a liquid also determines flow of the liquid. Thus heavier the molecule of a given liquid the greater will be its viscosity.
3. Structure and shape of the molecules of a liquid place an important role in influencing its viscosity. Liquids with the large irregularly shaped molecules are generally known to be more viscous than those with small and symmetrical molecule. Since only hard symmetrical molecules have perfectly elastic collision, the large and irregular molecules will have less elastic molecules amongst themselves. Thus collisions between large molecules involves the loss of kinetic energy and as a consequence the intermolecular forces dominating the molecules tends to stick together. This increases the viscosity of the liquid.
4. An increase in temperature decreases the viscosity of the liquid, the molecular motion increases at the expense of cohesive forces causing resistance to flow.
5. The increase of pressure goes to strengthen the cohesive forces between molecules. Hence with increase of pressure the viscosity of a given liquid increases somewhat.

The flow is a characteristic property of liquids. Let us consider flow of a liquid. A liquid may be considered to be consisting of molecular layers arranged one over the other. When shearing force is applied, it flows.

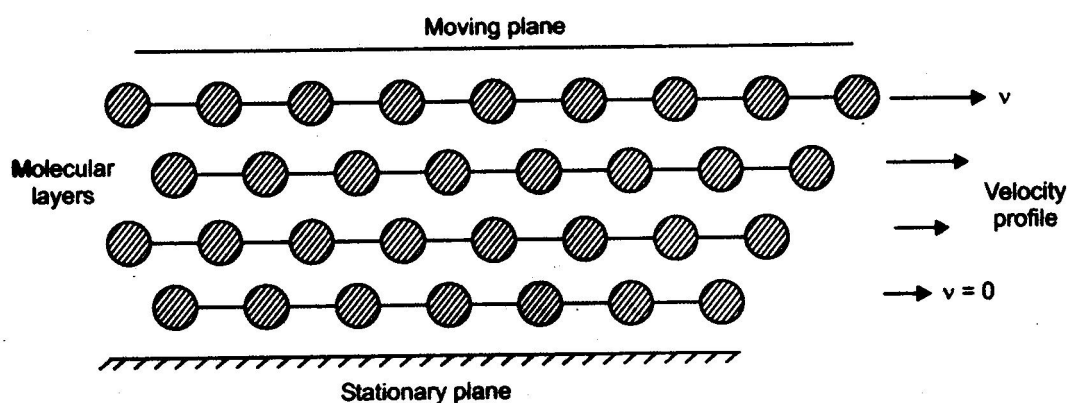

Fig 11.18 flow of liquid on a glass surface

However the force of friction between the layers offers resistance to this flow. Viscosity of a liquid is a measure of its frictional resistance.

Let us examine a liquid flowing on a glass surface. The molecular layer in contact with the stationary surface has zero velocity. The successive layers above it move with increasingly higher velocities in the direction of the flow.

Now consider two adjacent moving layers of a liquid (fig 11.18). Let these be separated by a distance dx having velocity difference $d v$. The force of friction (F) resisting the relative motion of the two layers is directly proportional to the area A and velocity difference $d v$, while it is inversely proportional to the distance between the layers dx .

$$\begin{aligned} \text{Hence} \quad F &\propto A \, d v/dx \\ &= \eta \, A \, d v/dx \\ \text{or} \quad \eta &= F/A \times dx/dv \end{aligned}$$

where η (eta) is the proportionality constant. It is known as coefficient of viscosity or simply viscosity of a liquid. It may be defined by the above equation as:

the force of resistance per unit area which will maintain unit different of velocity between two layers which are unit distance apart.

Unit of viscosity:

$$\begin{aligned} \eta &= F/A \times dx/dv \\ &= \text{force/area} \times \text{distance/velocity} \\ &= \text{mass} \times \text{length} \times \text{time}^{-2}/\text{length}^2 \times \text{length/length/time} \\ &= \text{mass} \times \text{length}^{-1} \times \text{time}^{-1} \end{aligned}$$

In CGS system the unit of η is expressed as $\text{g cm}^{-1}\text{s}^{-1}$, it is called poise. In practice smaller units centipoise (10^{-2} poise) and millipoise (10^{-3} poise) are used.

A liquid is said to have coefficient of viscosity as one poise when a force of one dyne maintains a velocity difference of one centimetre per second between two parallel layers of the liquid one cm apart and have an area of contact equal to one square cm. **The reciprocal of viscosity is known as fluidity.**

11.13.3.1 Effect of temperature on viscosity

As the temperature increases, the molecular motion increases at the expense of cohesive forces causing resistance to flow. Therefore, the viscosity of liquids is found to decrease by 1 to 2 per cent for each degree rise of temperature.

11.13.3.2 Determination of viscosity

The apparatus used for determination of viscosity in the laboratory is known as Ostwald's viscometer. A simple form of Ostwald viscometer is shown in fig 4.14, the left-hand limb is essentially a pipette with two calibration marks A and

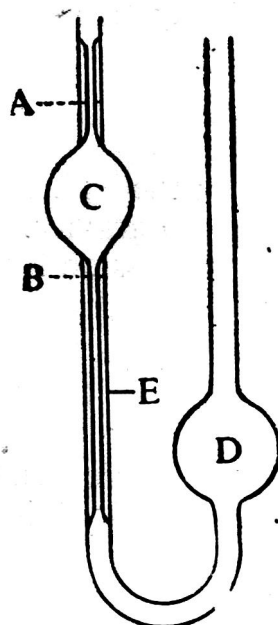

Fig 11.19 Ostwald viscometer

B. A length of capillary tube joins the pipette to the bulb D in the right-hand limb.

A definite volume of liquid (say about 25 ml) is poured into the bulb D with a pipette. The liquid is sucked up near to the top of the left-hand limb with the help of rubber tubing attached to it. The liquid is then released to flow back into the bulb D. the time t_1 to flow from A to B is noted with a stopwatch. Then the apparatus is cleaned and the experiment is repeated with water taking about the same volume. The time of flow of water t_2 from A to B is recorded. The density of the liquid d and that of water d_w are determined with the help of density bottle. The relative viscosity is calculated from the expression

$$\eta/\eta_w = dt_1/d_w t_2$$

where η is coefficient of viscosity of the experimental liquid and η_w is the coefficient of viscosity of water. Knowing the value of coefficient of viscosity of water η_w at the temperature of experiment, the absolute viscosity coefficient η of the given liquid can be found.

11.13.3.3 Viscosity and chemical constitution

As you know viscosity is largely due to intermolecular attractions which resist the flow of liquid. Therefore some sort of relationship between viscosity and molecular structure should be there. Viscosity is also dependent on the shape, size and mass of the liquid molecules. The following general rules have been discovered.

(i) Dunstan Rule:

Dunstan in 1909 showed that coefficient of viscosity η and molecular volume (d/M) were related as

$$d/M \times \eta \times 10^6 = 40 \text{ to } 60$$

This expression holds only for normal (unassociated) liquids for associated liquids the value is much higher than 60. For example the value for benzene is 73 and for water it is 559 and for ethanol it is 189. This shows benzene is a normal liquid while water and ethanol are associated liquids.

(ii) Molar Viscosity:

The product of molar surface and viscosity is termed as molar viscosity. That is molar viscosity = molar surface \times viscosity

$$= (M/d)^{2/3} \times \eta$$

Thorpe and Rodger (1894) found that molar viscosity is an additive property at the boiling point. They worked out the molar viscosity contributions of several atoms (C, H, O, S, etc) and groups. From these, they calculated the molar viscosity of liquid from its proposed structure. By tallying this value with the experimental one, they were able to ascertain the structure.

(iii) Rheochor:

Newton Friend (1943) showed that if molecular volume (M/d) be multiplied by the eighth root of the coefficient of viscosity it gives a constant value [R], it is termed as Rheochor

$$M/d \times \eta^{1/8} = R$$

Like parachor, rheochor is both additive and constitutive property.

11.14 REFRACTIVE INDEX

11.14.1 Definition

When a ray of light passes from air into denser medium say a liquid, it is bent or refracted towards the normal. The ratio of the sine of angle of incidence and the sine of angle of refraction is constant and characteristic of that liquid. This is known as Snell's law. **The constant ratio n is called refractive index of the liquid** and may be written as

$$\sin i / \sin r = n$$

The ratio of sines of the angles of incidence and refraction is identical with the ratio of the velocity of light in two media.

$$\text{Thus } n = \sin i / \sin r = \frac{\text{velocity in air}}{\text{velocity in liquid}}$$

when a ray of light passes from a rarer to denser medium it can be shown from law of refraction that

$$\frac{\sin i}{\sin r} = \frac{n_2}{n_1}$$

n_1 is refractive index of rarer medium

n_2 is refractive index of denser medium

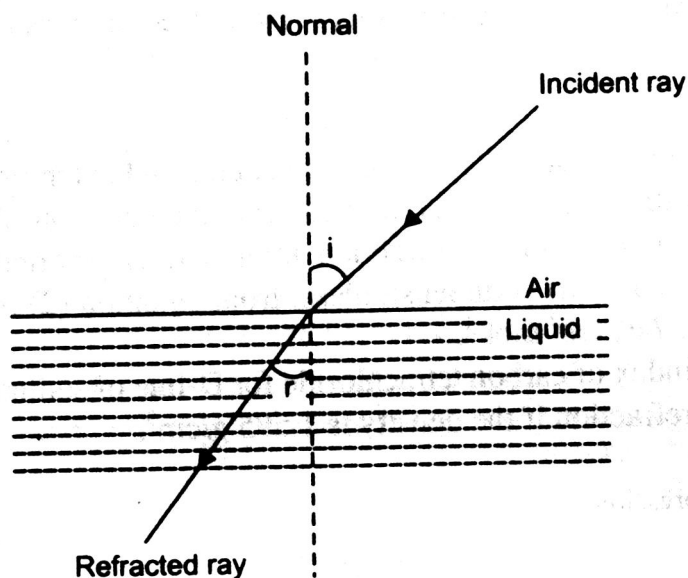

Fig 11.20

11.14. 1. Determination of refractive index

The instruments used for determining refractive index are known as refractometers.

Pulfrich-refractometer:

This refractometer is very accurate and simple in principle. It is indicated diagrammatically in fig 11.21. The main part of the instrument is a right angled glass prism with a small glass cell

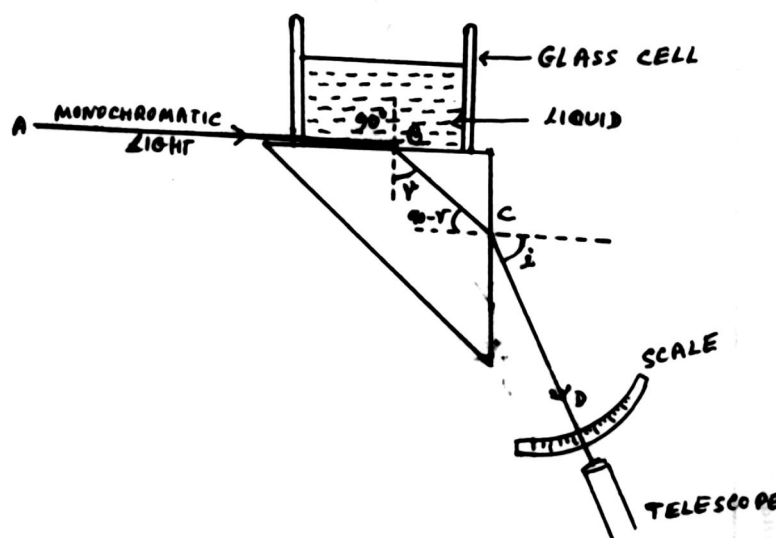

Fig 11.21 The optical system of Pulfrich refractometer

connected to its top. The liquid under examination is placed in the cell and a beam of monochromatic light is made to enter the liquid at an angle of 90° along the surface between the liquid and the prism. If the telescope is moved to make an angle with the horizontal which is less than *i* no light can reach it. At this angle *i* a sharp boundary between a dark and a bright field can be seen through the telescope.

For a ray of light passing from the liquid into the prism, if *r* be the angle of refraction when the angle of incidence is 90° we have already stated that $\sin r = n_1 / n_2$

$$\dots\dots(1)$$

Where *n*₁ is the refractive index of the liquid and *n*₂ is that of glass prism. It is also clear to you from the fig 4.16 that

$$\sin i / \sin (90-r) = n_2 \dots\dots(2)$$

$$\text{or } \sin i / \cos r = n_2 \dots\dots(3)$$

$$\text{or } \cos r = \sin i / n_2 \dots\dots(4)$$

But $\sin r = \sqrt{1-\cos^2r}$

substituting the value of *cos r* in equation (4)

we get

$$\sin r = \sqrt{(1 - \sin^2 i / n_2^2)} \quad \dots\dots\dots(5)$$

From equation (1) we get

$$\begin{aligned} n_1 \sin i &= n_2 \sin r \\ &= \sqrt{n_2^2 - \sin^2 i} \end{aligned}$$

If the refractive index n_2 of the glass is known and angle i is measured n_1 the refractive index n_1 of liquid can be calculated.

11.14.2 Refractive index and chemical constitution

Lorenz and Lozentz (1880) purely from theoretical considerations derived the following relation for refracting power of substance

$$R = \frac{n^2 - 1}{n^2 + 2} \times \frac{1}{d} \quad \dots\dots(1)$$

where R is specific refraction, d the density and n the refractive index. The value of R was constant at all temperatures.

Molar refraction:

It is defined as the product of specific refraction and molecular mass. Thus molar refraction is obtained by multiplying equation (1) by molecular mass (M).

$$R_M = \frac{n^2 - 1}{n^2 + 2} \times \frac{M}{d} \quad \dots\dots\dots(2)$$

The value of molar refraction is characteristic of a substance and is independent of temperature. Since it depends on wavelength of light, the values of molar refraction are generally reported for D-line of sodium.

Molar refraction R_M is an additive and constitutive property. The molar refraction of a molecule is thus a sum of the contributions of the atoms (atomic refraction) and bonds (bond refraction). From the observed value of R_M of appropriate known compounds, the atomic refractions of different elements and bonds have been worked out.

Carbon C	2.418	3-membered ring	0.710
Hydrogen H	1.100	4- membered ring	0.480
Chlorine Cl	5.967	6- membered ring	0.15

Bromine Br	8.861	O in OH group	1.525
Iodine I	13.900	O in C=O group	2.211
Double bond	1.733	O in ethers	1.64
Triple bond	2.398		

Table 11.3 some atomic and bond refractions

Now we will have some examples for you to illustrate the use of molar refractions in elucidating molecular structure

(i) Benzene :

The molar refraction of benzene (C_6H_6) on the basis of much disputed Kekule formula may be calculated as:

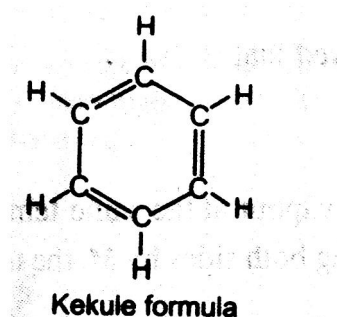

$$6C = 6 \times 2.591 = 15.546$$

$$6H = 6 \times 1.028 = 6.168$$

$$3C=C = 3 \times 1.575 = 4.725$$

$$\text{One 6 C ring} = -0.150$$

$$\text{Total } R_M = 26.289 \text{ cm}^3 \text{ mole}^{-1}$$

The observed value of R_M for benzene is 25.93. This is in good agreement with the calculated value. Hence the Kekule formula for benzene is supported.

Now let us take the example of ethyl alcohol (CH_3CH_2OH). Its refractive index is 1.3611 and its density is 0.7885 g cm^{-3} . The molar mass of ethyl alcohol is 46. The molar refraction can be calculated from the formula, and the value comes out equal to $12.9105 \text{ cm}^3 \text{ mol}^{-1}$.

anisotropic properties are associated with crystalline state, the turbid liquids are known as liquid crystals. This liquid crystal term, however, is not satisfactory since the substances in this state do not have properties of crystalline state. Actually, they are more like liquids in having properties like mobility, surface tension, viscosity etc. Amongst other names that have been suggested are crystalline liquids and anisotropic liquids, but these are also not satisfactory. The term mesomorphic state (meaning intermediate form) probably fits best. But, the older term liquid crystal continues to be used even in the present day literature.

Substances which show the above behaviour are usually some long chain organic molecules either terminating in groups such as -OR, -COOR or having groups like $-C=N-$, $N=NO-$, $-C=C-$ in the middle. The first solid showing this peculiar property was discovered in 1888 was cholesteryl benzoate $C_6H_5COOC_{27}H_{45}$. It fuses sharply at $145^{\circ}C$ to form turbid liquid and on further heating changes into clear liquid at $178^{\circ}C$. If we cool, the above changes are reversed i.e., the clear liquid when cooled first changes into turbid state at $178^{\circ}C$ and then into the solid state at $145^{\circ}C$.

Later on, p-azoxyanisole and p-azoxyphenetone were found to exhibit the same properties. In 1991 P.G. De Gennes, a French physicist got the Nobel Prize in Physics for contribution to liquid crystals and polymers.

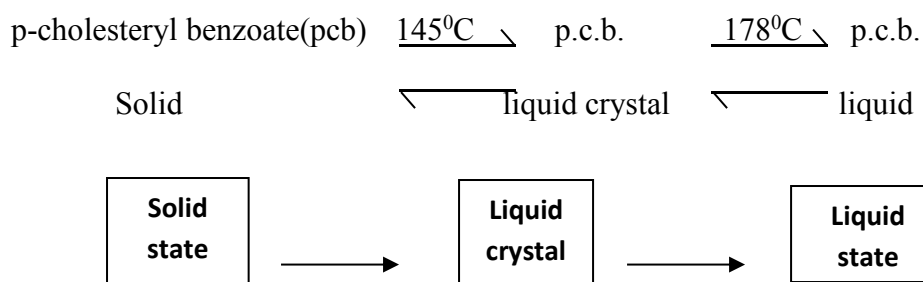

One such substance that forms liquid crystal is p-ozoxyanisole (11.22)

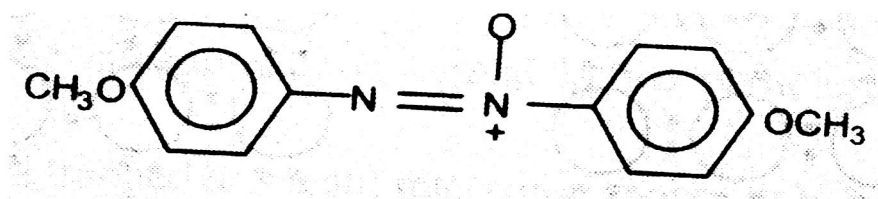

Fig 11.22 p-Ozoxyanisole

11.16 STRUCTURE OF LIQUID CRYSTALS

In a liquid the molecules have random arrangement and they are able to move past each other. In a solid crystal the molecules have an ordered arrangement and are in fixed positions. In a liquid crystal, however, molecules are arranged parallel to each other and can flow like a liquid. **Thus liquid crystals have the fluidity of a liquid and optical properties of solid crystals.**

Accordingly to their molecular arrangement, the liquid crystals are classified into three types

(i) Nematic liquid crystals:

in nematic liquid crystals molecules are parallel to each other like soda straws but they are free to slide or roll individually.

(ii) Smectic liquid crystals:

The molecules in this type of liquid crystals are also parallel but these are arranged in layers. These layers can slide past each other (Fig 4.18).

(iii) Cholesteric liquid crystals:

As in nematic crystals in this type liquid crystals the molecules are parallel but arranged in layers. The molecules in successive layers are slightly rotated with respect to the layers above and below so as to form spiral structure.

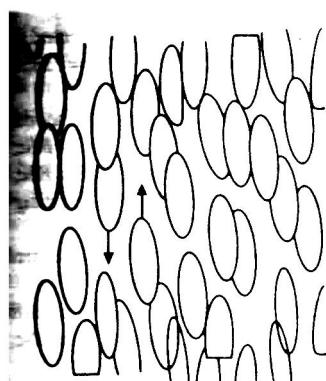

Nematic liquid crystal

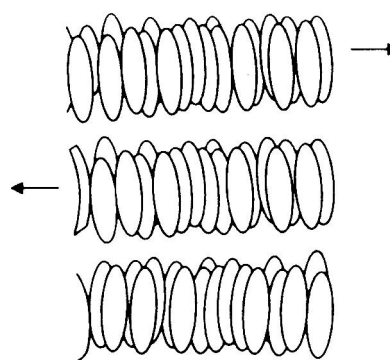

Smectic liquid crystal

Fig 11.23

Application of liquid crystals:

On account of their remarkable optical and electrical properties, liquid crystal found several practical applications. Some of these are given below.

Number display:

When a thin layer of nematic liquid crystal is placed between two electrodes and an electrical field is applied, the polar molecules are pulled out of alignment. This causes the crystal to be opaque. Transparency returns when electrical signal is removed. This property is used in the number displays of digital watches, calculators, and other instruments.

Monitoring body temperature:

Like the solid crystals, liquid crystals can diffract light. Only one of the wavelengths of the white light is refracted by the crystal which appears coloured. As the temperature changes the distance between the layers of molecules also changes. Therefore the colours of the reflected light changes correspondingly. These cholesteric liquid crystal undergoes a series of colour changes with temperature. These crystals are used in indicator tapes to monitor body temperature or to spot areas of overheating in mechanical systems.

11.17 SUMMARY

The summary of the present chapter is :

- Most characteristic property of gases is that their molecules lie far apart from each other and are in continuous motion. Each molecule, therefore, leads almost an independent existence. This property is so when temperature is high and pressure is low.
- Till now you have studied that a gas is said to be an ideal gas if it obeys Boyle's law and Charles's law rigidly for all values of temperature and pressure.
- In other words a perfect gas is one which strictly follows the general gas equation $PV = nRT$, since both the laws are contained in it. Actually no gas is perfect.
- They approach ideal behaviour as the temperature gets farther from their boiling points, so that at ordinary temperature the most nearly perfect gases are those like hydrogen and nitrogen which have very low boiling points.
- The study of kinetic theory of gases enables us to calculate molecular velocities. Which is otherwise very difficult to determine because gas molecules possess very high velocity and because of collisions the velocity changes within a very small time.

- In this unit you have studied liquid state in detail. Various properties of liquids such as vapour pressure, surface tension, viscosity and refractive index have been discussed and also their usefulness to elucidating molecular structure.
- The difference between liquid, liquid crystal and solid state have been discussed and also liquid crystal in detail.
- Though the study of the parachor, molecular viscosity, molar refraction etc. Are useful in elucidating molecular structure of compounds, but they give some rough idea about molecular structure.

Mass Spectra, I.R., NMR are the latest methods/techniques for elucidating molecular structure of organic compounds accurately.

11.19 REFERENCES

1. Atkins, P.W. Chemical Principles: the Quest for Insight, 3rd ed. 4North QD 33.2 .A74 2005.
2. Atkins, P.W. Elements of Physical Chemistry, 6th ed. 1 NORTH User Services Reserve QD 453.3 .A85 2013 pc
3. Atkins, P.W. Four Laws that Drive the Universe or 4 North QC 311.2 .A85 2007.
4. Atkins, P.W. Atkins' Physical Chemistry, 7th ed. 4 North QD 453.3 .A74 2002.
5. Francl, Michelle. Survival Guide for Physical Chemistry. 4North QD 458 .F72 2001.
6. Hofmann, Andres. Physical Chemistry Essentials. 4 North QD 453.3 .H64 2018.
7. McCaw, C.S. Orbitals: with Applications in Atomic Spectra. 4North QD 461 .M396 2015.

●

11.18 TERMINAL QUESTIONS

(A) Multiple Choice Questions

1. A real gas most closely approaches the behaviour of a perfect gas under the condition of
(a) High pressure and low temperature.

(b) Low pressure and high temperature.

(c) Low pressure and low temperature.

(d) High temperature and high pressure.

2. The compressibility factor of a perfect gas is

(a) Zero (b) One (c) more than one (d) Less than one.

3. The root mean square velocity of a gas molecule is given by

(a) $v_{\text{rms}} = \sqrt{\frac{3RT}{M}}$ (b) $v_{\text{rms}} = \sqrt{\frac{2RT}{M}}$

(b) (c) $v_{\text{rms}} = \sqrt{\frac{3RT}{\pi M}}$ (d) $v_{\text{rms}} = \sqrt{\frac{2RT}{\pi M}}$

4. The free path is the distance travelled by the molecule

(a) Before collision (b) in one second

(b) After collision (d) in one minute

5. Compressibility factor is represented as

(a) $Z = \frac{PV}{RT^2}$ (b) $Z = \frac{RT}{PV}$ (c) $Z = \frac{2PV}{RT}$ (d) $Z = \frac{PV}{RT}$

6. How many molecules are present in 0.2 g of hydrogen?

(a) 6.023×10^{23} (b) 6.032×10^{22} (c) 3.0125×10^{23} (d) 3.0125×10^{22}

7. The reciprocal of viscosity is known as:

(a) Anti viscosity (b) intrinsic viscosity

(c) Reduced viscosity (d) Fluidity

8. The molecules which have partial positive charge at one end and partial negative charge at the other are called:

(a) ion pairs (b) charged molecules

(c) dipole (d) electric molecule

9. With the rise of temperature the surface tension of a liquid:

(a) Increases (b) decreases

(c) remains the same (d) none of the above

10. The unit in which surface tension is measured is:

10. Write a note on specific refraction.
11. Write a note on liquid crystals.
12. Explain the term viscosity of a liquid.

(C) Long Answer Questions

1. Narrate the various methods of producing cold, and show how these have been used in liquefaction of gases.
- 2 (a) Define Joule-Thomson effect. Explain inversion temperature. How is it related to von der Waal's constants.

(b) The von der Waal's constants a and b for a gas are $0.045 \text{ dm}^3 \text{ atm mole}^{-2}$ and $0.026 \text{ dm}^3 \text{ mole}^{-1}$ respectively. Calculate the inversion temperature of the gas.
3. (a) State Maxwell's law or distribution of velocities. How does a change in temperature influence this distribution?

(b) Define three different types of velocities. How are they related with each other?
- 4 (a) Define the terms:
 - (i) Critical temperature.
 - (ii) Boyles temperature.
 - (iii) Conversion temperature.(b) Write a note on collision diameter.
5. Define the terms surface tension and surface energy. Discuss capillary rise method for determination of surface tension in the laboratory.
6. What are liquid crystals? How are they classified? How would you account for turbidity observed in liquid crystals? What are the uses of liquid crystals?
7. Why do you use the same viscometer for the liquid and water during the experimental determination of the viscosity of the liquid by Ostwald viscometer? Describe the experiment.
8. (a) Define viscosity of a liquid. What is the effect of temperature on viscosity?

- (c) Water passes through a viscometer in 30 seconds and ethanol in 175 seconds at 20°C. If the density of water is 0.998g/cm³, density of ethanol is 0.790g/cm³ and viscosity of water is 0.01008 poise, calculate the viscosity of ethanol.

(Hint : use formula $\eta = \eta_w dt_1/dwt_2$

ans 0.01747 poise)

9. Write notes on the following

- (a) Vapour pressure
- (b) Optical oxaltation
- (c) Ramsay- Shields equation

Answer key (A) MCQs

1 b	2 b	3 a	4 a	5 d	6 b
7 d	8 c	9 b	10 b	11 d	12 b

UNIT 12 : SOLID STATE

CONTENTS:

- 12.1 Introduction
- 12.2 Objective
- 12.3 Definition
- 12.4 Definition of space lattice and unit cell
- 12.5 Laws of crystallography
 - 12.5.1 Law of constancy of interfacial angle
 - 12.5.2 Law of rational indices
 - 12.5.3 Law of symmetry
- 12.6 Symmetry elements of a Crystal
- 12.7 Lattice sites and coordination number
- 12.8 X-ray diffraction of crystals
 - 12.8.1 Bragg's equation
 - 12.8.2 Rotating crystal method
 - 12.8.3 Powder Method
- 12.9 Structure of crystal system NaCl, KCl and CsCl
- 12.10 Born Haber cycle
 - 12.10.1 Lattice energy
 - 12.10.2 Definition
- 12.11 Summary
- 12.12 Terminal Questions
- 12.13 References

12.1 INTRODUCTION

It is clear to you now that intermolecular attraction is minimum in the gaseous state and this disappears completely when the gas is ideal. The interaction is stronger in liquids and is strongest in solids. Thermal motion of the molecules increases or decreases by raising or lowering of temperature. The attractive interaction between the molecules tries to keep them together and the thermal motion is opposed to that. Hence, it is possible to change a substance from one state to another by changing its temperature.

A true solid possesses the following characteristics

- (a) A sharp melting point
- (b) A characteristic heat of fusion
- (c) General incompressibility
- (d) A definite three-dimensional arrangement

Hence solids are characterised by high density and low compressibility compared to those of the gas phase. In solids, atoms, ions and molecules are held together by relatively strong chemical forces- ionic bond, covalent bond, or by intermolecular von der Waal's forces. They do not translate although they vibrate to some extent on their fixed positions. This explains why solids are rigid and have definite shape.

12.2 OBJECTIVES

In this unit you will be able to:

- In gaseous state you have studied that if thermal energy is much greater than the forces of attraction then we have matter in gaseous state.
- Molecules in gaseous state move with very large speeds and because of very small attraction forces, the gas molecules move practically independent of one another.
- In the liquid state the forces of attraction are greater than the thermal energy.
- You have also studied that molecules in liquid state too have kinetic energy, they cannot move very far away because of the larger forces of attraction amongst them.
- Because of this property, liquids have definite volume, but they do not have definite shape. Liquids also resemble gases in their ability to flow. Gaseous and liquid states are, therefore, both classified as fluids.

- Out of the three states of matter, solids are characterised by incompressibility, rigidity and mechanical strength. The molecules, atoms or ions in solids are closely packed.

12.3 DEFINITION

Solids can generally be classified into two broad categories:

- (i) Crystalline solids
- (ii) Amorphous solids

A crystalline solid exists as small crystals, each crystal having a characteristic geometrical shape. In a crystal, the atoms, molecules or ions are arranged in a regular, repeating three-dimensional pattern called the crystal lattice. examples are sugar, salt etc.

An amorphous solid has atoms, molecules or ions arranged at random and lacks the ordered crystalline lattice. Examples of amorphous solids are rubber, plastics and glass. In their disordered structure, amorphous solids are regarded as supercooled liquids with high viscosity. The liquid nature of glass is sometimes apparent in very old window panes that have become slightly thicker at the bottom due to gradual downward flow.

Anisotropy and isotropy:

Amorphous substances differ from crystalline solids and resemble liquids in another important aspect. Their properties such as electrical conductivity, thermal conductivity mechanical strength and refractive index are same in all directions. Amorphous substances are said to isotropic. Liquids and gases are also isotropic. Crystalline solids on the other hand are anisotropic, because their physical properties are different in different directions. For example the velocity of light through a crystal varies with the direction in which it is measured. Thus, a ray of light enter such a crystal may split up into two components each following different velocity. This phenomenon is known as double refraction. This can be shown in fig 5.1 in which simple two-dimensional arrangement of

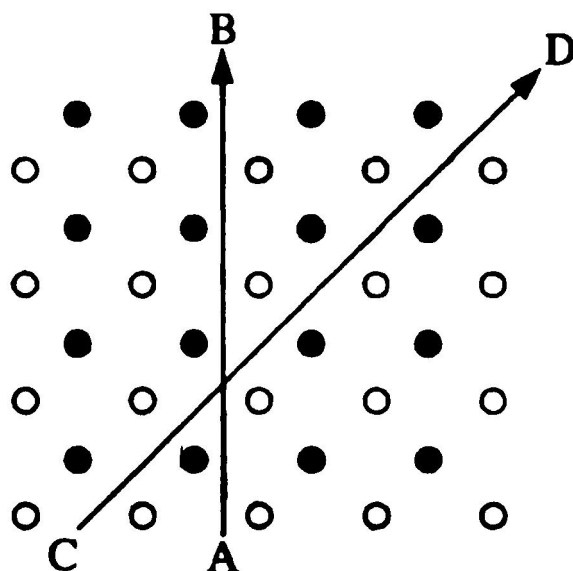

Fig 12.1 Anisotropy in crystals is due to different arrangement of particles in different directions

only two different kinds of atoms is depicted if the properties are measured along the direction indicated by the slanting line CD, they will be different from those measured in the direction indicated by the vertical line AB. The reason is that while in the first case, each row is made up of alternate types of atoms, in the second case; each row is made up of one type of atoms only. In amorphous solids, atoms or molecules are arranged at random and in a disorderly manner and, therefore all directions are identical and all properties are alike in all directions.

12.4 DEFINITION OF SPACE LATTICE AND UNIT CELL

Crystals are bound by surface which is usually planner. These surfaces are called faces and where two faces intersect an edge is formed. The angle between the normals to the two intersecting faces is the interfacial angle or the angle between any two faces is called interfacial angle. Although the size of the faces or even shapes of crystals of one and the same substances may vary widely with the condition of formation or other factors, yet the interfacial angles

between any two corresponding faces of the crystal remain invariably the same throughout. This is shown in fig 5.2. Now it is clear to you that although the external shape is different yet the interfacial angles are the same.

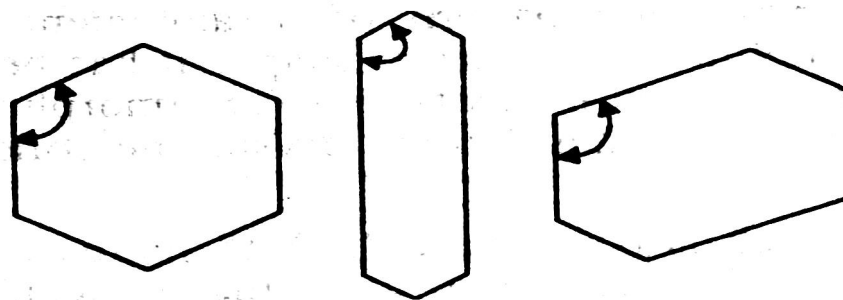

Fig 12.2 Constancy of interfacial angle

Space lattice

Rather than drawing the entire pattern, it is much more convenient to represent the unit of pattern by a point. Each point then represents the position of an atom, ion, molecule or group of ions and molecules. The regular three-dimensional arrangement of identical points in space gives rise to what is known as space lattice or crystal lattice (Fig 12.3) the positions occupied by the particles in the space lattice are called lattice sites or lattice points.

Unit cell:

It is defined as “the smallest geometrical portion of the crystal, which when repeated in three dimensional, would generate the complete crystal”. Each unit cell, in turn, must be constituted of atoms, molecules or ions, as the case may be and arranged to give the particular geometrical configuration of the crystal.

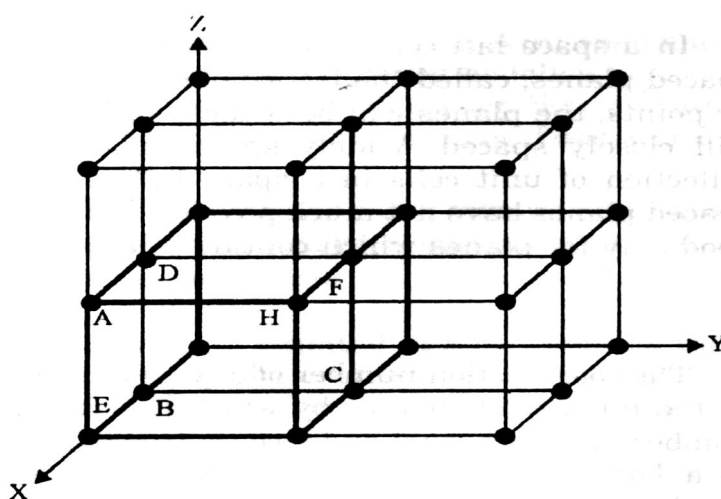

Fig 12.3 Space lattice

Unit cells are of following types;

- (a) **Simple or primitive unit cell (P):** The simplest unit cell which has the lattice points at the corners is called a simple or primitive unit cell. It is denoted by P.

(b) **Non primitive or multiple unit cell:** When unit cell contains more than one lattice points, it is called non primitive or multiple unit cell. It is further divided into the following three categories:

(i) **Face centred unit cell (F):**

When a unit cell, besides the points present at the corners of the unit cell,

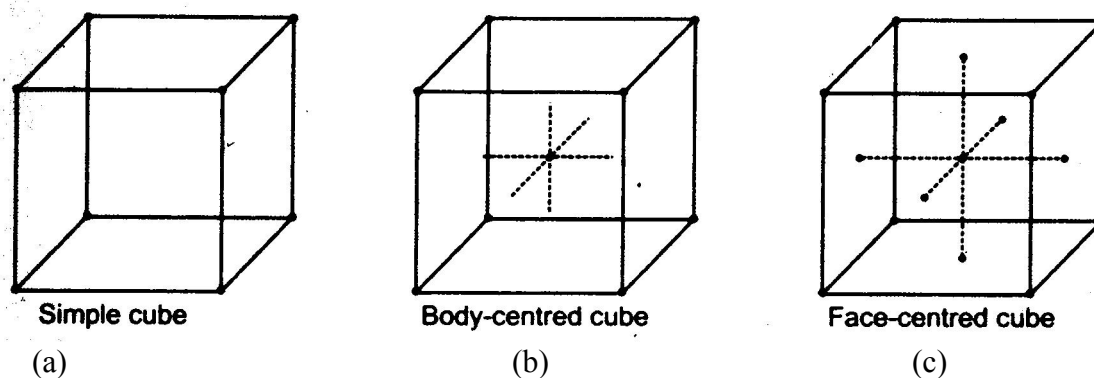

Fig 12.4 Three cubic unit cells

There is one point at the centre of each face, it is called face centred arrangement or face centred unit cell. It is denoted by F.

(ii) **Body centred unit cell (I):**

When in a unit cell, besides the points at the corners of the cell, there is one point at the centre within its body, it is called body-centred arrangement or body-centred unit cell. It is denoted by I.

(iii) **Side centre or end face unit cell:**

When in a unit cell, besides the points at the corners of the cell, the points are located at the centre of any two parallel faces of the unit cell, it is called side-centred or end face unit cell. It is denoted by c.

12.5 LAWS OF CRYSTALLOGRAPHY

There are three laws of crystallography which deal with the interfacial angles and the rational indices.

12.5.1 Law of constancy of interfacial angle

The crystal may be smaller or bigger in size and may be prepared by any method, but the interfacial angles are always the same.

12.5.2 Law of rational indices

Now it will be clear to you that crystal lattice consists of unit cells arranged in parallel planes. Thus each crystal plane lies parallel to the crystal face as also to the unit cell face. These planes cut the three axes along the three crystallographic axes (ox, oy, oz), Haüy proposed that a given crystal plane could be described in terms of intercepts along the axes. The reciprocals of these intercepts are small whole numbers, these numbers h,k and l are called Miller indices after the name of British Scientist W.H. Miller. Thus Miller indices of a plane may be defined as the reciprocals of the intercepts which the plane makes with the axes.

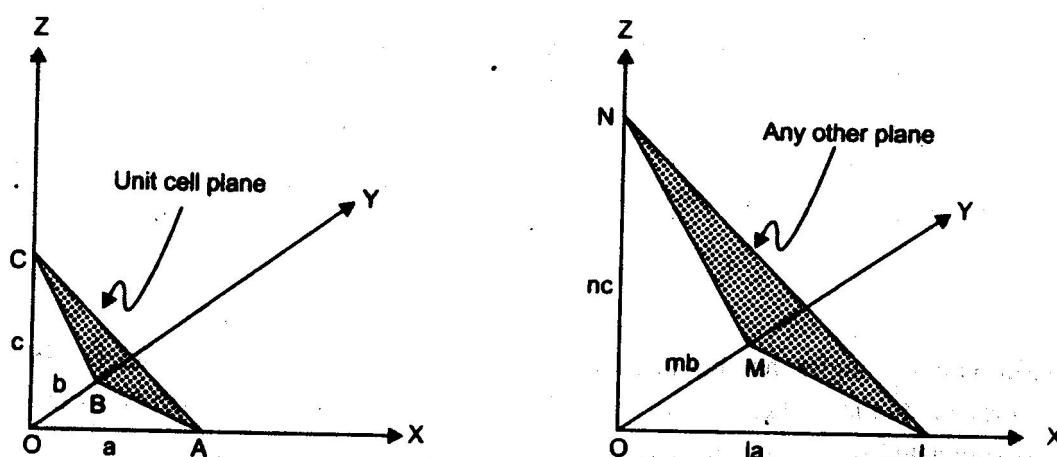

Fig 12.5 A unit cell plane intercepts the axes to give intercepts a, b and c

Any other plane intercepts the axes to give intercepts equal to la, mb and nc

For example let us consider a crystal system with the axes OX, OY and OZ. In fig 5.4 ABC represents a unit cell surface while LMN in fig 5.5 depicts another crystal plane under study. The intercepts of the unit plane are OA, OB and OC which have the length a, b and c respectively. The intercepts of the plane under study are OL, OM and ON. These can be expressed as multiples of the intercepts a, b, c i.e. la, mb and nc. Here l, m and n are either integral whole numbers or fraction of whole numbers. The reciprocal of these numbers are written together in brackets (h,k,l) to give the Miller indices of the plane under study.

To find the Miller indices proceed as follows.

- (i) Write the intercepts as multiples of a, b, c say la, mb, nc
- (ii) Take the reciprocals of l, m and n
- (iii) Clear fraction to get whole numbers h, k, l.

(iv) Miller indices to the plane are (h,k,l).

Example: calculate the Miller indices of crystal planes which cut through the crystal axes at

(i) 2a,	3b,	c	(ii) 6a,	5b,	3c	
(i) a	b	c	(ii) a	b	c	
2	3	1	intercepts	6	3	3
1/2	1/3	1	reciprocals	1/6	1/3	1/3
3	2	6	clear fraction	1	2	2

Hence Miller indices are (326)

hence Miller indices are (122)

12.5.3 Law of symmetry

Besides the interfacial angles, another important property of crystals is their symmetry. The law of symmetry states that:

All crystals of the same substance possess the same elements of symmetry.

Symmetry in crystals may be with respect to a plane, a line or a point, accordingly there are three types of symmetry associated with a crystal.

12.5.3.1 Plane of symmetry

When an imaginary plane can divided a crystal into two parts such that one is the exact mirror image of the other, the crystal is said to have a plane of symmetry.

12.5.3.2 Axis of symmetry

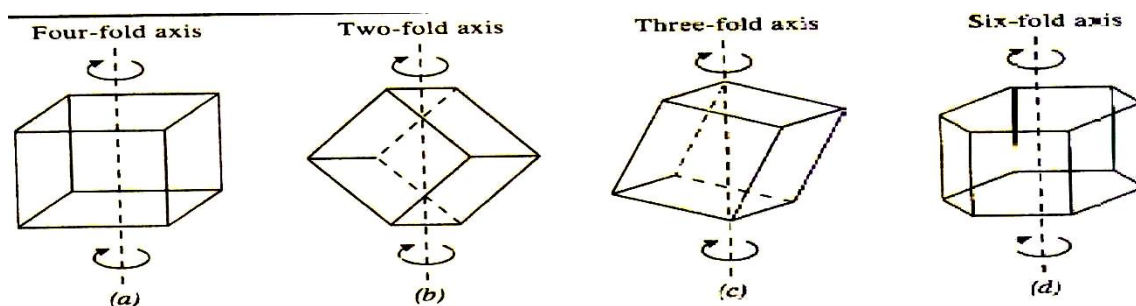

An axis of symmetry is a line about which the crystal is rotated such that it presents the similar appearance more than once during complete rotation i.e. rotation through an angle of 360°. Depending upon its nature, a crystal may have 2-fold, 3-fold, 4-fold or 6-fold axes of rotation.

Fig 12.6 various axes of symmetry

For example in the case of a cube, an axis passing perpendicularly through the centre is such that when the cube is rotated it presents similar appearance in three rotation of 90° each and the same appearance after the fourth rotation, such an axis is called a four-fold or tetrad axis

(fig 5.6(a)). If the same similar appearance is repeated after an angle of 180° , the axis is called two-fold or diad axis (fig 5.6(b)). In the same way, if the same or similar appearance is repeated after an angle of 120° , the axis is called a three-fold or triad axis (fig 5.6(c)). If the same or similar axis is repeated after an angle of 60° , as in the case of a hexagonal crystal, the axis is called six-fold or hexad axis (fig 5.6(d)). In general, if the same or similar appearance of a crystal is repeated on rotation through an angle of $360/n$, around an imaginary axis, the axis is called an n-fold axis.

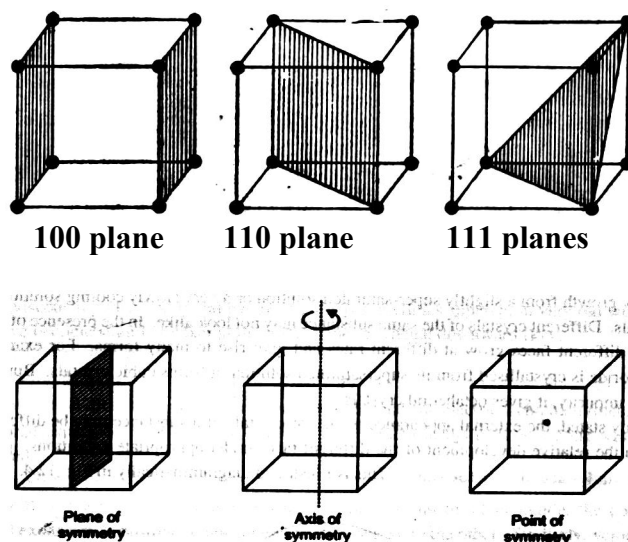

Fig 12.8 three cubic unit cells

12.5.3.3 Centre of Symmetry

It is a point at the centre of the crystal so that any line drawn through it will meet the surface of the crystal at equal distance on either side.

It may be pointed out that a crystal may have number of planes or axis of symmetry but it has only one centre of symmetry.

12.6 SYMMETRY ELEMENTS OF A CRYSTAL

Any crystal or any molecule of the crystal will have some combinations of symmetry elements. These combinations of symmetry elements are known as point groups. These point groups are called classes or systems.

Sr. No.	Crystal System	Axial length of Unit Cell	Inter axial angles	Number of Lattice in the system
1	Cubic	$a = b = c$	$\alpha = \beta = \gamma = 90^\circ$	3
2	Tetragonal	$a = b \neq c$	$\alpha = \beta = \gamma = 90^\circ$	2
3	Orthorhombic	$a \neq b \neq c$	$\alpha = \beta = \gamma = 90^\circ$	4
4	Monoclinic	$a \neq b \neq c$	$\alpha = \beta = 90^\circ \neq \gamma$	2
5	Triclinic	$a \neq b \neq c$	$\alpha \neq \beta \neq \gamma \neq 90^\circ$	1
6	Trigonal	$a = b = c$	$\alpha = \beta = \gamma < 120^\circ, \neq 90^\circ$	1
7	Hexagonal	$a = b \neq c$	$\alpha = \beta = 90^\circ, \text{ and } \gamma = 120^\circ$	1

Table 12.1 seven crystal systems

A careful study of the geometrical structure of crystals reveals that there are 230 crystal forms, which may be grouped into 32 classes. These 32 classes in turn may be referred into to seven crystal systems.

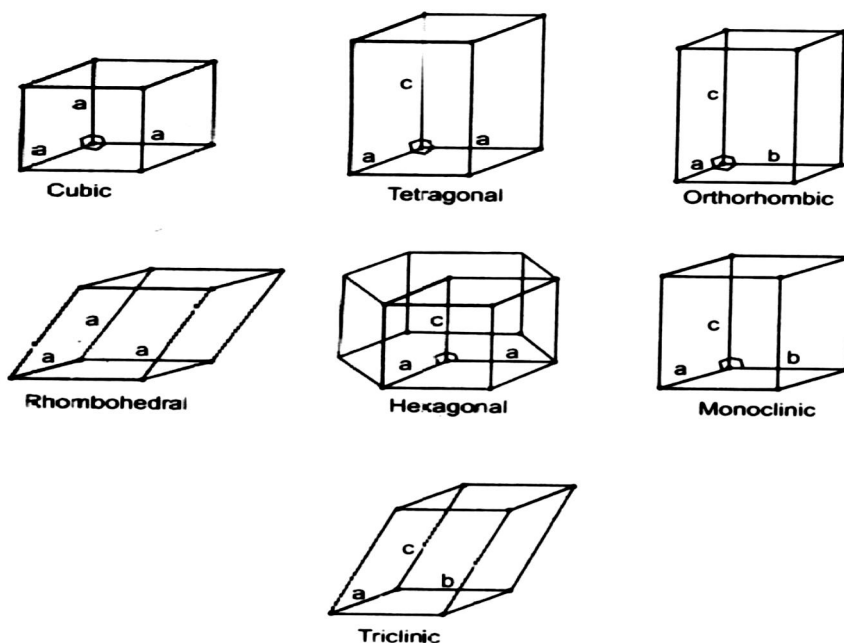

Fig 12.7 seven crystal systems

These Crystal systems differ in length of the unit cell edges (a, b and c fig 5.1) and the angles between the unit cell edges.

12.7 LATTICE SITES AND COORDINATION NUMBER

From the above discussion it may be clearly understood that it is possible to have lattice sites other than the corners of the geometrical patterns. In fact for the simplest lattice system, i.e., the cube, there may be three possibilities. These possibilities are named as ‘simple cubic’, ‘body centred cubic’ and ‘face centred cubic’ depending upon the lattice sites being disposed in space in a manner that a particle is situated at any of these is surrounded in an identical manner by other particles of the lattice. In the simple cubic lattice, fig 5.6(a), the particles are occupying only the corners of the cube. The body centred cubic lattice fig 5.6 (b) has particle at the centre of the cube in addition to the four occupied corners. But in face-centred cubic lattice fig 5.6 (c) there is one lattice site at each of the six faces of the cube apart from the four corner sites.

Let us now calculate the number of particles, atoms or ions

- (i) In simple cubic unit cell one particle is situated at each corner and there are eight corners in the unit cell. So each corner atom is shared by 8 unit cells, hence share of each unit cell is one-eighth. Thus number of particles in one unit cell is, $z = 1/8 \times 8 = 1$ particle.
- (ii) In body centred cubic unit cell, 8 particles are situated at 8 corners and one particle at the centre of the cube. As each corner is shared by eight unit cells, so sharing of 8 corners = $8 \times 1/8 = 1$ particle. One particle in the centre of the unit cell and hence $z = 1 + 1 = 2$ particles.
- (iii) In face centred cubic unit cell, 8 particles are situated at eight corners. So their share is $8 \times 1/8 = 1$ particle. One particle is situated at the centre of the 6 faces which is shared by 2 unit cells. So, the share of 6 faces = $6 \times 1/2 = 3$ particles. So $z = 1 + 3 = 4$ particles.

Coordination number

Coordination number or legancy is defined as the number of particles immediately adjacent to each particle in the crystal lattice.

If you carefully examine a given space lattice, in simple cubic lattice each particle is adjoined by six other particles and so the coordination number of simple cubic system is six.

The coordination number of body-centred cubic system is eight and that of face-centred cubic system is 12 respectively.

12.8 X-RAY DIFFRACTION OF CRYSTALS

You know that when x-rays were first investigated, problem arose of measuring their wave length. It is a well known fact that, if light is allowed to strike a surface consisting either of a series of edges or lines spaced closely enough to be of the same order of magnitudes as that of the wavelength of light, the beam of light is diffracted. And the various radiations are dispersed into a series of spectra known as, first, second, third etc. order of spectra. Further, there is definite relation between the angle of diffraction, the wavelength of radiation and the spacing of the lines on the ruled grating. Since x-rays are of the same nature as light, it should be theoretically possible to determine the wavelength of this radiation in the same way. However it is impossible by any mechanical means to rule a grating as fine as that required, namely one with 10^8 lines per centimeter. For this purpose Laue (1912) suggested that crystal can act as grating to x-rays as wavelength of x-rays is comparable to the interatomic distance. When a beam of x-rays is allowed to fall on a crystal, a large number of images of different intensities are formed. If the diffracted waves are in the same phase, they reinforce each other and a series of bright spots are produced on a photographic plate placed in their path. On the other hand, if the diffracted waves are out of phase, dark spots are caused on the photographic plate (fig 5.8). From the overall diffraction pattern produced by a crystal, can arrive at the detailed information regarding the position of particles in the crystal.

12.8.1 Bragg's equation

Bragg's pointed that the scattering of x-rays by crystal could be taken to be equivalent to reflection from successive planes of atoms in the crystal. However the reflection of x-rays can take place only at certain angles which are dependent on wavelength of the x-rays and the distance between the planes of the crystal. The fundamental equation which gives a simple relation between the wave length of x-rays, the interplaner distance in the crystal and the angle of reflection is known as Bragg's equation. This equation can be derived as follows.

The horizontal lines represent parallel planes in the crystal structure separated from one another by a distance d . suppose a beam of x-rays incident at an angle falls on the crystal.

Some of them will be reflected from uppermost plane at the same angle, while the other will be absorbed and get reflected from successive planes, as shown in

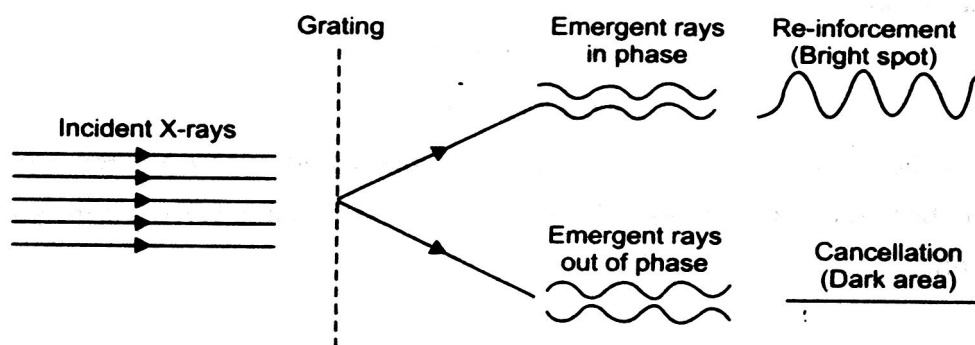

Fig 12.8 diffraction patterns produced by crystals

Let the planes ABC and DEF drawn perpendicular to the incident and reflected beams, respectively. The waves reflected from different planes will be in phase with one another only if the difference in the path length of the wave reflected from the successive planes is equal to an integral number of wavelengths. Drawing perpendicular OL and OM to the incident and reflected beams, it will be seen that the path difference in the wavelength, say δ of the wave reflected from the first two planes is given by

$$\delta = LN + NM \quad \dots\dots\dots (1)$$

This should be equal to a whole number multiple of wavelength λ , i.e.

$$n\lambda = LN + NM \quad \dots\dots\dots(2)$$

Since the two triangles ONL and ONM are congruent $LN = NM$

$$n\lambda = 2LN = 2d\sin\theta \quad \dots\dots\dots(3)$$

Equation (3) is known as Bragg's equation.

For a given set of lattice planes, d has a fixed value.

Therefore possibility of getting maximum diffraction (i.e., the possibility of getting reflected waves in phase with one another) depends upon θ . If θ is increased gradually, a number of positions will be found at which the reflection will be maximum. At these positions, n will have values 1,2,3,4...etc. generally, in experiments on x-ray diffractions, any set as equal to 1. If λ is known, it is possible to determine d , the distance between atomic planes in the crystal by determining θ experimentally. Thus if d is known λ can be calculated.

Measurement of diffraction angle:

The x-ray diffraction techniques used in the study of crystals are of two types known as rotating crystal method and powder method. Both these techniques make use of the x-ray spectrometer, the setting of which for the former technique is shown in Fig 5.8.

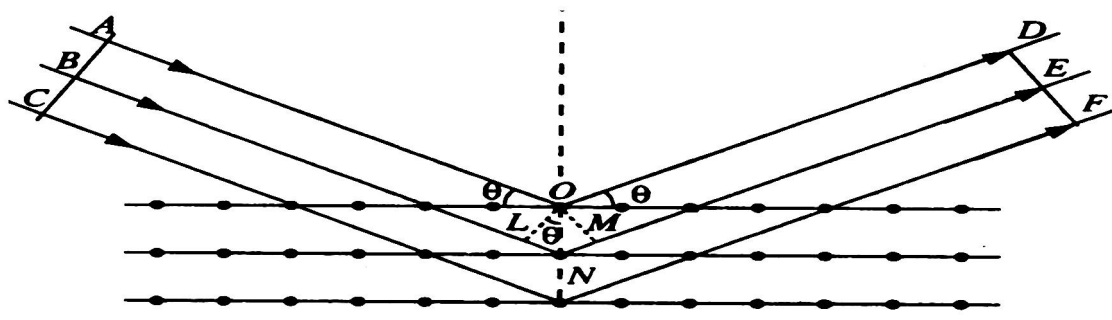

Fig 12.9 x-ray diffraction by crystals

12.8.2 Rotating crystal method

x-ray generated in the tube T are passed through a slit so as to obtain a narrow beam which is then allowed to strike a single crystal C mounted on the turn table. The crystal is rotated gradually by means of the turn table so as to increase the glancing angle at which x-rays are incident at the exposed phase of the crystal. The intensities of the refracted rays are measured on a recording device R. The recording device may be either a photographic plate or an ionisation chamber. The angle for which reflections are maximum give the value of θ . The process is carried out for each plane of the crystal. The lowest angle at which maximum reflection occurs corresponds to $n=1$. This is called first order reflection. The next higher angle at which maximum reflection occurs again, corresponds to $n=2$. This is second order reflection, and so on.

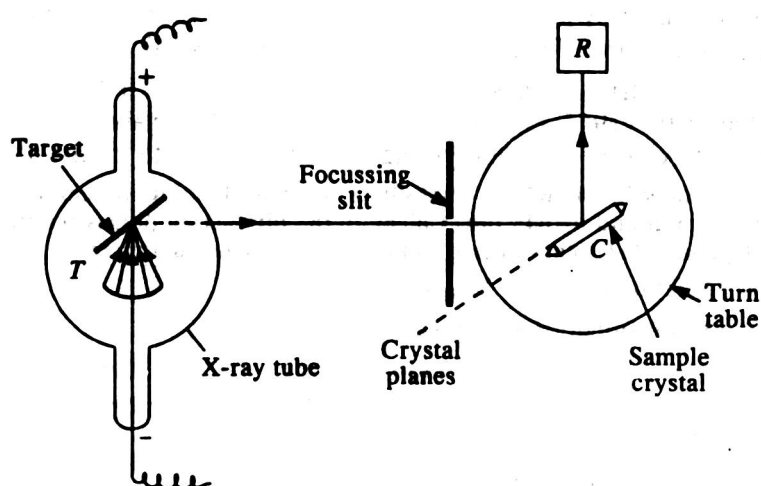

Fig 12.10 Rotating crystal method

12.8.3 Powder Method

Power method is the simplest technique for obtaining x-ray diffraction. It was first used by P.J.W. Debye and P. Scherer. Instead of taking a single crystal having a definite orientation to the impinging x-rays, we can take a mass of finely divided crystal with random orientation

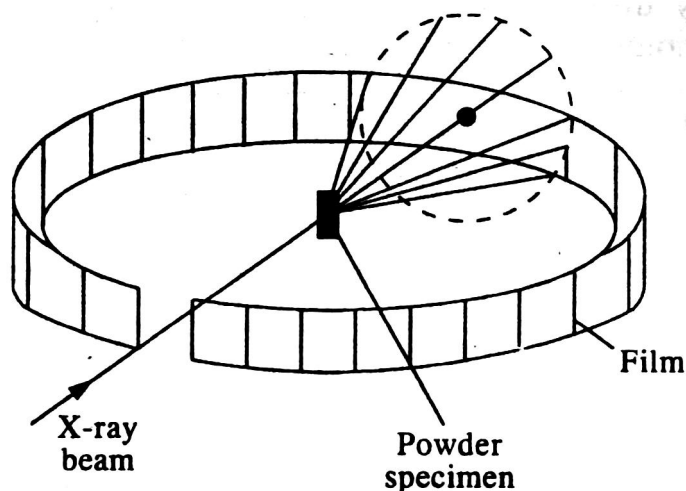

Fig 12.11 The powder method

This method is better adopted due to its simplicity and versatility. In this method, the crystal sample is need not to be taken in large quantity but a little as one milligram of the material is sufficient for study. The powder, in fact consists of many small crystals which are oriented in all possible directions. As a result of this x-rays are scattered from all set of planes (e.g., 100,110, etc.). The scattered rays are detected by using an x-ray sensitive film. The principle is shown in Fig 12.9. A narrow beam of x-rays is allowed to fall on the powder. The diffracted x-rays strike a strip of photographic film arranged in the form of circular arc, as shown in the Fig 12.11.

In this method no rotation is necessary since the powder sample already contains microcrystal arranged in all possible orientations. Hence, a large number of them will have their lattice planes in correct positions for maximum x-ray reflection to occur. As a result of this we get lighted areas in the form of arcs of lines at different distances from the incident beam as shown. These distances can be converted into scattering angles to be used in the Bragg's equation for different planes of crystals.

12.9 STRUCTURE OF CRYSTAL SYSTEM NaCl, KCl and CsCl

Structure of NaCl crystal

The ionic crystal of NaCl is shown in Fig 5.12. Each sodium ion is surrounded by six chloride ions and each chloride ion is surrounded by six sodium ions. The maximum intensity of reflection occurs at the glancing angle of 5.9° , 8.4° and 5.2° for 100, 110 and 111 planes, respectively for first order reflection.

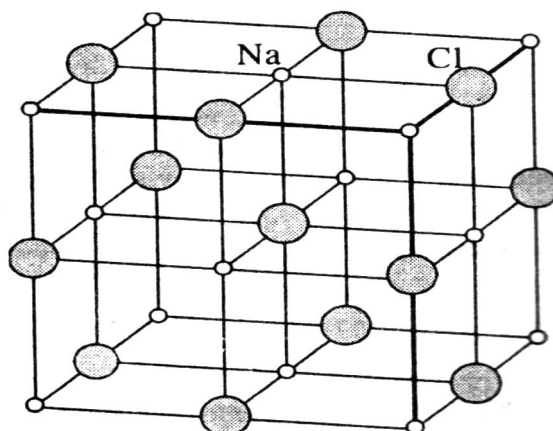

Fig 12.12 Structure of NaCl crystals

We know that,

$$n\lambda = 2d\sin\theta$$

or $\frac{1}{d} = 2 \frac{\sin\theta}{n\lambda}$

Therefore for a particular order of reflection

$$d \propto 1/\sin \theta$$

If only first order reflection are considered than,

$$\begin{aligned} d_{100}:d_{110}:d_{111} &= 1/\sin 5.9^\circ: 1/\sin 8.4^\circ: 1/\sin 5.2^\circ \\ &= 1/0.103: 1/0.146: 1/0.091 \\ &= 1:0.704:1.155 \end{aligned}$$

For face-centred cubic system the planes can be passed through the atom having Miller indices 100, 110 and 111 at the relative spacing $a/2:a/2\sqrt{2}:a/\sqrt{3}$

$$\begin{aligned} \text{So } d_{100}:d_{110}:d_{111} &= a/2:a/2\sqrt{2}:a/\sqrt{3} \\ &= 1:0.707:1.154 \end{aligned}$$

This ratio is almost identical with the ratio we have calculated from experimental observations. Hence NaCl crystal is face-centred cubic system.

Structure of KCl crystal

On investigating the KCl crystal, the maximum reflection of x-rays, corresponding to first order reflections are observed to occur at the glancing angles of 5.38° , 7.61° and 9.38° for (100), (110) and (111) faces, respectively,

Therefore,

$$\begin{aligned} d_{100}:d_{110}:d_{111} &= 1/\sin 5.38^\circ:1/\sin 7.61^\circ:1/\sin 9.38^\circ \\ &= 1:0.704:0.575 \end{aligned}$$

For the simple cubic system the planes can be passed through the atoms having Miller indices (100), (110) and (111) and the relative spacing for the unit cell is $a:a/\sqrt{2}:a/\sqrt{3}$

$$\text{So } d_{100}:d_{110}:d_{111} = 1:0.707:0.577$$

Therefore, KCl crystal has a simple cubic lattice.

Potassium Chloride is isomorphous with sodium chloride. The explanation for this apparent anomaly is very simple and can be explained on the basis that the x-rays scattering power for an atom or ion is governed by the number of extra-planetary electrons. viz. atomic number.

The atomic numbers of potassium (K=19) and chlorine (Cl=17) are not very different and the x-rays are unable to detect any difference between the two kinds of atoms. If we imagine all the atoms to be identical, it is evident that face-centred arrangement has become a simple cubic arrangement. This is the reason for the KCl spectrum corresponding apparently to the simple cubic lattice. With KCl, the structure is face-centred, but the face-centred characteristics are marked by the fact that the two types of atoms composing the substance have nearly the same atomic numbers and atomic weights (K=39, Cl=35.5). But in the case of sodium chloride the atomic numbers differ considerably (Na=11, Cl=17), and so their

Structure of CsCl crystal

scattering powers are different and hence the true structure as two interpenetrating face-centred lattices become apparent. It is only the (111) face spectra which allows us to

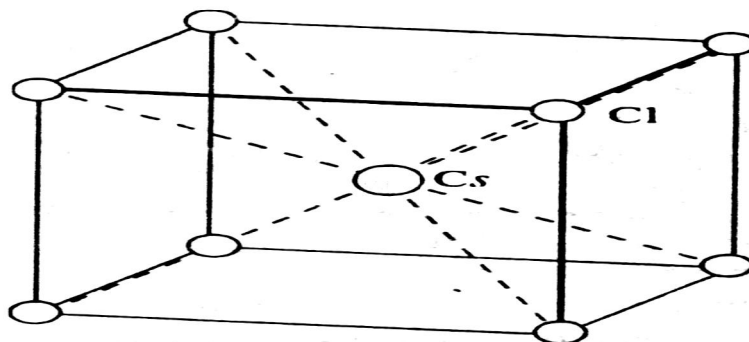

Fig 12.13 Cesium chloride crystal lattice

distinguish between the simple cubic lattice and the face-centred cubic lattice. Cesium chloride, CsCl, has a body centred cubic structure. In its crystal lattice, each Cs^+ ion is surrounded by 8 Cl^- ions and its coordination number is 8. The value of distance between Cs^+ ion and Cl^- ion as determined by Bragg's spectrometer is 3.510^0A Fig 12.11.

The **diamond lattice** consists of a series of atoms, each of which is placed between four neighbours. The latter occupies the angular points of a regular tetrahedral, while atom under consideration lies in the centre. The type of structure runs throughout the crystal. The C-C bond distance is 0.154 nm. The whole lattice is continuous Fig 5.14. The diamond crystal is regarded as giant molecule. The crystal is very hard because the covalent links runs without a break throughout the whole crystal. The crystal can be cut only by breaking the covalent links. High melting point can also be explained by stating that the atoms are very firmly attached within the crystal.

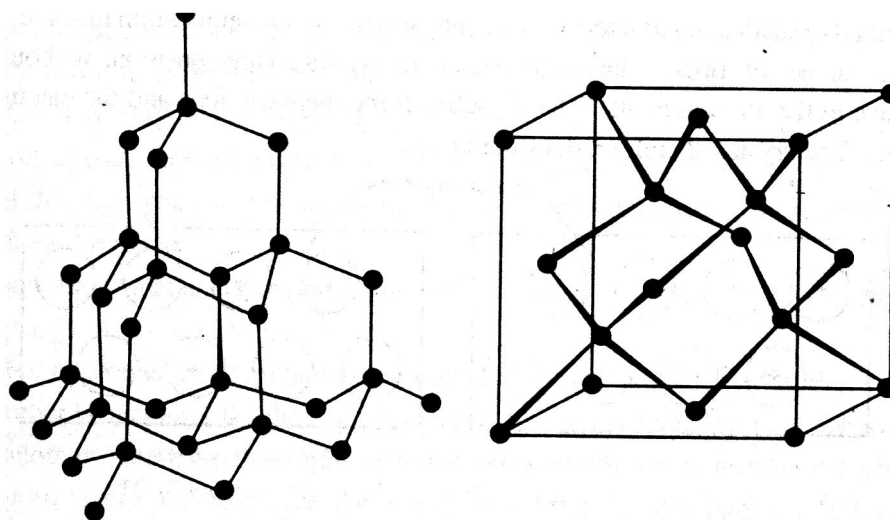

Fig 12.14 crystal structure of diamond

Though diamond and graphite are both covalent crystals. The great difference between graphite and diamond can be understood in terms of the crystal lattice. Graphite has hexagonal networks in sheets like benzene rings. The distance between atoms in the plain is 142 pm but the distance between these atomic layer planes is 335 pm. In two directions the carbon atoms are tightly held as in diamond, but in the third direction, the force of attractions appreciably less. As a result one layer can slip over the other. The crystal are flatty.

Examples:

Q.1 At what angle (θ) will x-rays of wavelength 1.542×10^{-10} m, be reflected by plains separated by 3.5×10^{-10} m.

Solution:

From Bragg's equation $2d\sin\theta=n\lambda$

$$\sin\theta=n\lambda/2d$$

$$\theta=\sin^{-1}n\lambda/2d$$

$$\theta=\sin^{-1}1 \times 1.542 \times 10^{-10} / 2 \times 3.5 \times 10^{-10}$$

$$=12.73^{\circ} \quad \text{ans}$$

Q.2 Metallic gold Au=197 is face centred cubic lattice. Calculate (a) how many atoms occupy the gold unit cell and (b) what is the mass number of a gold unit cells.

Solution:

Corner atom is shared by 8 unit cells, hence share of one unit cell is 1/8, for 8 corners $1/8 \times 8 = 1$ atom

There are six faces, each contain 1 atom and share of one unit cell is $1/2$ and for six faces $\frac{1}{2} \times$

$6 = 3$ atoms

So $1 + 3 = 4$ atoms occupy the gold unit cells.

$$\text{Mass of gold atom} = \frac{\text{molar mass}}{\text{Avagadro number}}$$

$$= 197\text{g/mole} / 6.022 \times 10^{23} \text{ Au atoms/mole} \times 1/4$$

$$= 8.178 \times 10^{-23} \text{ g ans}$$

Q.3 Diffraction angle $2\theta = 16.8^{\circ}$. for a crystal having interplaner distance in the crystal is 0.400nm when second order reflaction was observed. Calculate the wavelength of the x-rays used.

Solution:

Given that $n=2$, $d=0.400\text{nm} = 0.4 \times 10^{-9}\text{m}$, $2\theta=16.8^{\circ}$, so $\theta=8.4^{\circ}$

Now $2d\sin\theta=n\lambda$

$$\lambda=2/2 \times 0.4 \times 10^{-9} \times \sin 8.4^{\circ} \text{m}$$

$$= 0.4 \times 10^{-9} \times 0.146 \text{m}$$

$$= 0.584 \times 10^{-10} \text{m}$$

$$= 0.584 \text{ \AA}^{\circ} \quad \text{ans}$$

12.10 BORN HABER CYCLE

(determination of lattice energy of an ionic crystal)

12.10.1 Lattice energy

The positive and negative ions in an ionic crystal are held together by electrostatic forces. The bond energy is expressed in terms of the lattice energy.

12.10.2 Definition

The change in enthalpy (heat change) that occurs when 1 mole of a solid crystalline substance is formed from its gaseous ions is known as lattice energy.

Born-Haber cycle is used to determine the lattice energy of a ionic solid. The lattice energy of sodium chloride, for example is the change in enthalpy, ΔH^0 , when Na^+ and Cl^- ions in the gas phase come together to form 1 mole of NaCl crystal.

Process of obtaining sodium chloride can be obtained in the following steps:

- (a) Conversion of sodium metal to gaseous atoms (sublimation), energy required for this sublimation process is $\Delta H=S$

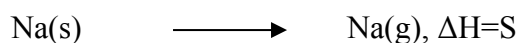

- (b) Conversion of gaseous sodium to sodium ions by losing electron. Energy required for ionisation is I.



- (c) Dissociation of chlorine molecule to chlorine atoms. Energy required for this process is $\frac{1}{2}D$

As half molecule is dissociated

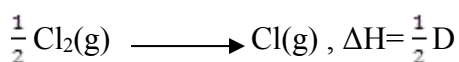

- (d) Chlorine atoms gain electron to form chloride ions. Energy released is the electron affinity E.

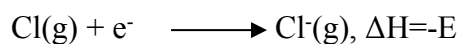

- (e) Sodium and chloride ions get together and form the crystal lattice. Energy released in this process is known as lattice energy and is equal to U.

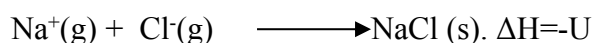

The enthalpy change for the direct formation of sodium chloride for sodium metal and chlorine is heat of formation ΔH^0 . This amount of heat is released in this process.

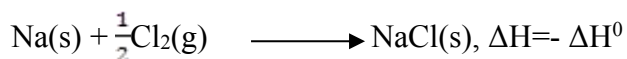

Equating these two we get,

$$-\Delta H^{\circ} = S + I + \frac{1}{2} D - E - U$$

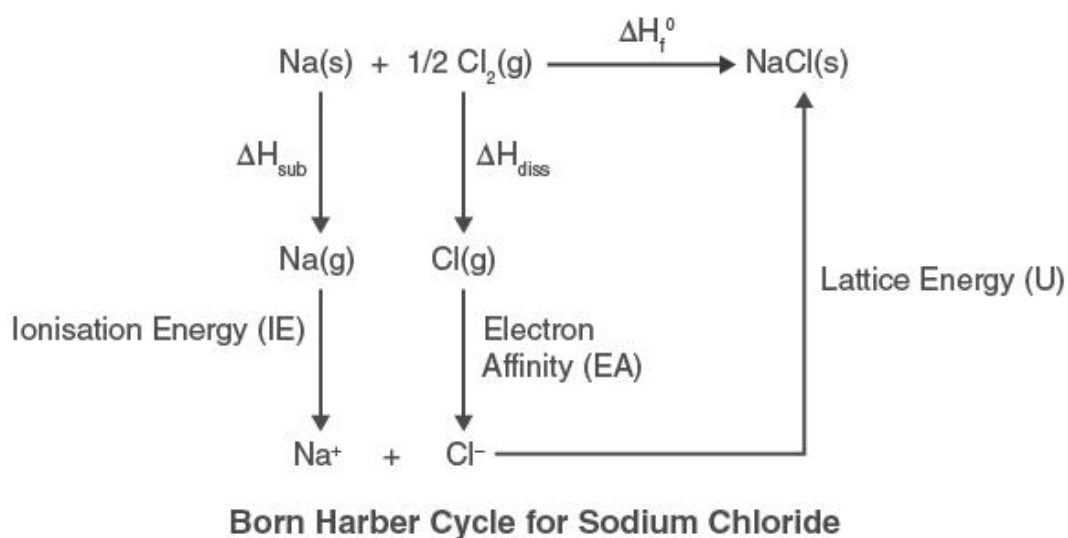

Fig 12.16 Born-Haber cycle

The cycle of changes shown in Fig 5.16 is called Born-Haber Cycle named after Max Born and Fritz Haber, who used this method for calculating lattice energies of crystals.

Thus lattice energy U can be calculated from the above equation.

12.11 SUMMARY

The summary of the present unit is:

- In this unit you have studied details of solid state in general and crystalline state in particular.
- You have studied difference between crystalline state and amorphous state, the various law of crystallography.
- The importance of Bragg's Equation which can be used for calculating Avogadro's number. In molecular crystals the forces which hold the constituents of von der Waals type.
- These are weaker because of which molecular crystals are soft and having low melting points example are CO_2 , CCl_4 , Ar and most of the organic compounds.
- In ionic crystals forces involved are electrostatic and these are stronger. Therefore, the ionic crystals are strong and likely to be brittle. The melting points are high, which

decreases with increasing size of ions. In covalent crystals, the forces involved are of chemical nature (covalent bonds).

- They are strong, and consequently the crystals are strong and hard with high melting points examples are diamond, silicon, etc. In metallic crystals, electrons are held loosely and hence they are good conduction of electricity. Metallic crystals can be bond and are also strong.

12.12 TERMINAL QUESTIONS

(A) Multiple choice questions:

- Q.1 Tetragonal crystal system has the following unit of dimensions
- (a) $a \neq b \neq c$ and $\alpha = \beta = \gamma = 90^\circ$ (b) $a = b \neq c$ and $\alpha = \beta = \gamma = 90^\circ$
 (c) $a = b \neq c$ and $\alpha = \beta = 90^\circ, \gamma = 120^\circ$ (d) $a = b = c$ and $\alpha = \beta = \gamma = 90^\circ$
- Q.2 In the crystal of CsCl , the nearest neighbours of each Cs^+ ion are :
- (a) six Cl^- ions (b) six Cs^+ ions
 (c) Eight Cl^- ions (d) six Cl^- ions
- Q.3 The Bragg's equation for diffraction of x-rays is:
- (a) $n\lambda = d \sin\theta$ (b) $n = 2d \frac{\sin\theta}{\lambda}$
 (c) $n\lambda = 2d^2 \sin\theta$ (d) $n\lambda^2 = 2d \sin\theta$
- Q.4 Which is incorrect for hexagonal crystal system
- (a) $a = b = c$ (b) $a = b \neq c$
 (c) $\alpha = \beta = 90^\circ, \gamma = 120^\circ$ (d) none of these
- Q.5 The total number of atoms in a body-centred cubic unit cell each:
- (a) 1 (b) 2 (c) 3 (d) 4

(B) Short Answer questions

- Q.1 Explain the terms anisotropy and isotropy
- Q.2 Account for the following:
 "Graphite and Diamond are both allotropic forms of carbon yet graphite is soft while diamond is hard."
- Q.3 Why is rotation of crystal is not necessary in powder method for the determination of crystal structure?
- Q.4 Write a short note on rational intercepts.

Q.5 Define the terms:

- (i) unit cells (ii) plane of symmetry (iii) law of constancy of interfacial angle.

(C) Essay type questions

Q.1 Derive Bragg's equation for diffraction of x-rays by a crystal lattice. How is this equation used in elucidating the crystal structure?

Q.2 (i) Derive the equation $2d \sin \theta = n\lambda$

- (ii) Draw structure of NaCl crystal.

Q.3 Write notes of the following:

- (a) Laws of crystallography
(b) Anisotropy and isotropy
(c) Power method for the determination of crystal structure.

Q.4 (a) Differentiate between crystalline and amorphous solids.

- (b) What is lattice energy? How lattice energy can be determined by Born-Haber cycle?

Q.5 (a) Enumerate various elements of symmetry of a cubic type unit cell.

(b) Draw diagrams to represent:

(i) Face centred cubic lattice.

(ii) Body centred cubic lattice.

Answer key (Multiple choice)

1 b 2 c 3 b 4 a 5 b

12.13 REFERENCES :

1. Essentials of Physical Chemistry By B.S. Bahl, Arun Bahl, G.D. Tuli.
2. Principles of Physical Chemistry by Puri and Sharma.
3. Under graduate Physical Chemistry by J.N. Gurtu.

BLOCK -V: LABORATORY WORK

UNIT 13: LABORATORY HAZARDS AND SAFETY PRECAUTIONS

CONTENTS:

- 13.1 Introduction
- 13.2 Objective
- 13.3 Purpose of laboratory & chemical safety
- 13.4 Types of hazards in the laboratory and their prevention
- 13.5 Laboratory safety
- 13.6 Assess and minimize the risk of the hazards
- 13.7 Summary
- 13.8 Bibliography

13.1 INTRODUCTION

In the laboratory it is required great care and attention in order to avoid safety hazards. Accidents occur due to delicate lab instrument, open flames, hazardous chemicals etc. Negligent handling of dangerous/harmful chemicals can result in both short-term (acute) and long-term (Chronic) health issues. Burns, eye injuries, lung diseases, asphyxiation, and suffocation are some of these potential issues. Chemicals cause adverse reactions in the body through ingestion, inhalation, skin contact, and percutaneous exposure. No matter how much is being used or how it is used, a substance, operation, or activity has intrinsic hazardous characteristics or properties. Various risks to human health and physical injury can be posed by chemicals given below:

Health Hazards	Physical Hazards
Toxic	Combustible
Carcinogenic	Flammable
Mutagenic	Explosive
Reproductive toxins	Reactive or pyrophoric
Sensitizers	Oxidizers
Irritants and Corrosives	Corrosive
Asphyxiants	Compressed Gas and Liquid

The chemistry practical could involve a minor incident. Inform your teacher or the lab attendant right away, remain calm, do not panic, and use the first aid provided in the laboratory.

However, if any of these symptoms occur, you should immediately stop working, take off your personal protective equipment, wash your hands, and contact your healthcare provider.

- Unusual taste or odor,
- Respiratory irritation, coughing, choking, or shortness of breath,
- Sudden headache, dizziness, blurred vision, or loss of consciousness,
- Burning or painful sensation,
- Swelling, reddening, or itching skin.

13.2 OBJECTIVE

After completing this unit learners will be able

- To know ‘What is a laboratory hazard’? The physical hazards and the chemical hazards in the laboratory.
- How to prevent chemical hazards in the laboratory.
- To know the effect of laboratory incidents on learner’s health, such as heat burns, glass cuts, and the inhalation of gas.
- To assess and reduce the risks associated with chemical hazards in the laboratory.

13.3 PURPOSE OF LABORATORY & CHEMICAL SAFETY

- To promote safety awareness and encourage safe working practices in the laboratory.
- Safety guidelines should serve as a reminder of things you can do to work more safely and are applicable to all users of the laboratory.
- All learners are expected to adhere to safety guidelines and maintain safety standard strictly.

13.4 TYPES OF HAZARDS IN THE LABORATORY AND THEIR PREVENTION

Chemical and physical hazards in the laboratory fall into five major categories. Now discuss each category in details with their prevention in the laboratory.

- Chemical burns
- Heat burns
- Eyes injuries
- Injury from glassware
- Inhaling dangerous gases

13.4.1 Chemical burns

Acids, bases, etching solutions and solvents are commonly used in chemistry lab and classified as corrosive substance, and also present a serious health hazards such as chemical burns, tissue damage, organ damage, asphyxiation, corneal damage, which can lead to blindness and genetic damage if used improperly.



(Burns are a common type of hazard when dealing with harmful substances).

- Wear the gloves when working in lab.
- If the skin burn with acid , wash it with ammonium hydroxide, while in case of concentrated H_2SO_4 wash affected part with Barium chloride solution and then with cold water and apply burnol.
- If the skin burn due to the concentrated/ strong alkali (base), washed it with acetic acid and finally with cold water and apply burnol. If the injury is deep then immediately contact with the health consultant/doctor.

13.4.2 Heat burns

Burners and other heating devices are frequently used in laboratories to expedite chemical reactions and processes. As with any activity that involves fire, it is important to be aware of the potential risks associated with heat-related injuries. If exposed to temperatures higher than 70°C , it is likely that a burn will occur, even if the skin is only exposed for a split second.

It is essential to maintain a safe distance away from open flames and heating devices in order to reduce the likelihood of heat-related burn injuries in the laboratory.

- Skin clothing and protective equipment should be kept away from any other combustible materials in the vicinity. Furthermore, it is imperative to ensure that burners are not left on after use.
- If a heat-related burn occurs while in the laboratory, it is recommended to immediately put the affected area in cold running water and hold it for a few minutes before allowing the burning sensation to subside. After that apply coconut oil or burnol on the burnt part.



(The heat generated by Bunsen burners can create a range of serious physical hazards for laboratory learner who are using the equipment)

13.4.3 Eye injuries

In the laboratory at the time of working, you need to be aware of the chemicals that can be harmful to your eyes. You can be exposed to chemicals if you accidentally release liquids or gases that can damage your eyes. The severity of your injury depends on hazardous properties of chemical are and how much you have been exposed to it. For instance, if you get a mild eye injury from exposure to a chemical, it could just cause redness and irritation. But if you get a really bad eye injury, it could lead to permanent blindness. To prevent eye injuries in the lab, you need to wear the right protective eyewear.

- If the eyes injuries occur due to the some pungent vapours in the eye first go away from the working place (lab) in the open place and wash your eye with cold water. If still eatvhing persists consult an eye doctor immediately.

- If chemical solution or dust particle enter into eye then wash your eye with cold water until you feel relief.
- If acid has been entered into eye then eye must be washed with a dilute solution of alkali sodium bicarbonate solution few times and after that with cold water till you feel relief. an eye doctor
- If base/alkali has been entered into eye then eye must be washed with dilute boric acid solution and finally washed with cold water till irritation persists. If still problem exist immediately consult an eye doctor.

13.4.4 Injury from glassware

The use of laboratory glassware for the storage and mixing of hazardous chemicals is a common practice; however, there is a risk of laboratory glassware breaking. If the glass is broken, it can expose sharp edges, particularly if it is very thin, which can cause severe eye and skin damage. Therefore, it is important to take steps to reduce the risk of glass breaking in laboratories.

- In order to prevent cuts from glassware, it is important to handle the glassware with caution. It is recommended to hold the glassware in a secure grip and to avoid handling the glassware with wet or wet hands.
- It is important to ensure that when glassware is not in use, it is stored in a safe and secure place where there is no potential for it to fall and shatter. If glassware is not stored in an accessible cupboard with a well-maintained and even surface, it is likely to fall and break, potentially exposing to physical injury.
- If the is due to the breakage of some glassware, glass apparatus, wound washed with spirit and then aqueous alum solution because alum is antiseptic in nature and can also help in stop bleeding by coagulation.
- It is essential to take prompt action in the case of a glass cut in order to avoid the development of an infection. If a cut is sustained from glassware, the first aid officer/doctor should be contacted so that they will dress the wound.

13.4.5 Inhaling dangerous gases

A wide variety of hazardous chemicals emit toxic vapors and gases that pose a risk to human life. The health consequences associated with exposure to these hazardous vapors can be

classified as acute, chronic, or both. Acute consequences are those that occur immediately after exposure to the vapors. Chronic consequences are those that do not occur immediately but occur months and even years after exposure. Health effects of gas inhalation can include symptoms such as:

Irritation to mucous membranes in the nose, throat, respiratory tract; Headache; Vomiting; Coughing; Burning; Difficulty in breathing etc.

- If you feel any symptoms occurs due to the inhalation of gases first go away from the working place (lab) in the open place. If still feel some problems consult with doctor immediately.

13.5 LABORATORY SAFETY

In the laboratory following safety will be taken while working in the lab.

- (i) Laboratory hygiene
- (ii) Fire safety
- (iii) Chemical safety
- (iv) Personal safety

(i) Laboratory hygiene

- Scrub hands thoroughly when finished.
- Avoid cross contamination
- Do not touch self, faucets, doorknobs, notebooks, pens etc. with gloves on.
- Keep a pen or two in your drawer for lab use only.
- Clean and disinfect your workspace

(ii) Fire safety

- Never leave flames unattended.
- Do not use flammables near ignition sources.
- Fire Extinguishers
- Fire Blanket
- Fire alarm pulls

(iii) Chemical Safety

- Wear gloves and glasses where appropriate.
- Follow instructor's directions.
- Dispose of waste properly-Do Not pour down the drain.

(iv) Personal Safety

- Lab coat to be worn all the time.
- Safety goggles must be worn all the time while working in the lab.
- Wear sensible clothing and Wear shoes.
- Appropriate gloves while handling chemicals.
- Working of alone student is not allowed

13.6 ASSESS AND MINIMIZE THE RISK OF THE HAZARDS

When you are working in a chemical lab, there is a risk associated with every chemical and glassware you use. Once you have evaluated the risks, your next step is to consider how you can reduce exposures. There are following step to assess and minimize the risk of hazards in the laboratory.

13.6.1 Before an experiment

This is likely the most significant steps you can take to reduce the risk in any laboratory environment. While incidents can occur even in the well-prepared environment, meticulous attention to detail can reduce the risk.

- I. Know what you are working with. It is important to always recognize the substance that is being used and to consider how to reduce the exposure to that substance during the experiment. For example, sodium hydroxide is commonly known as lye or caustic soda. If you are unsure, look for the Chemical.
- II. Ensure that the proper concentrations are prepared. In laboratory should not routinely work with basic (NaOH) or acidic (HCl) solutions at concentrations greater than 1 M.
- III. Ensure that all chemical bottles are properly labeled. For example sodium hydroxide, the bottle should have the chemical name (“sodium hydroxide”) spelled out, not just the formula (“NaOH”), and the concentration of the solution should also be listed.
 - The signal words “Danger”, “Warning”, and “Caution” are used to describe the level of the hazard.
 - Words such as “Caustic”, “Corrosive”, and “Flammable” are used to describe specific hazards.

- IV. Write down all the chemicals you are going to use and how much you will need for the experiment.
- V. Consider the physical arrangement and the facilities available in your laboratory.

13.6.2 During an experiment

It is essential that learners are monitored consistently in the laboratory. The teacher must be physically present in the duration of the experiment, focusing on the students throughout.

- I. Use the lowest concentrations and smallest volumes possible for all chemicals. Do not allow learners to handle solids that are classified as fatal or toxic if swallowed.
- II. Wear appropriate eye protection that offers both impact and splash protection. This is not only for your safety but also as a precaution in the event that an accident is caused by someone else in the laboratory.
- III. Wear appropriate protective clothing (laboratory apron, coat, and gloves).
- IV. Long hair must be pulled back, and clothing must be tucked in.
- V. After transferring a chemical (solid or liquid) from a reagent bottle into a secondary container, be certain that the reagent bottle and the container are properly closed.
- VI. Students should take only the amount required of each reagent. If there is excess, it must be disposed of properly and not returned to the reagent container.
- VII. No mixing of chemicals should be allowed, other than that specified in an experimental procedure.

13.6.3 What if an emergency occurs?

- I. If the chemical is in the eye: Flush water using an eyewash station for at least 15 minutes. Medical attention must be summoned as soon as possible.
- II. If the chemical is swallowed or ingested: Do not induce vomiting unless the SDS recommends vomiting. Medical attention must be summoned as soon as possible.
- III. If the chemical comes into contact with skin: Rinse the affected area for 15 minutes with tap water. It may be necessary to use a safety shower. If the safety shower is used, all contaminated clothing should be removed while the person is under the safety shower, and medical attention must be summoned as soon as possible.

13.6.4 After an experiment

- I. Return any chemicals (excess reagent, product, or waste) to the appropriate location, or dispose of them as instructed.
- II. Clean any used glassware and return the items to the appropriate location.
- III. Ensure that all chemicals are properly stored. Make sure that the caps on the reagent bottles are tightly secured.
- IV. Ensure that benches are clean before the next class comes in. One of the major causes of accidents is carelessness on the part of someone else.
- V. All gas outlets are closed; especially burners were used during the experiment.

13.7 SUMMARY

- Keep tabletops clean. Return all equipment to its original location before leaving the lab.
- Report all accidents, no matter how minor, to the instructor. If you break something made of glass, be sure to use dustpan and hand broom to sweep it up and dispose of it in the glass waste receptacle.
- In case of an emergency where we have to evacuate, proceed out the nearest exit.
- Both the door should remain open all the time while working in the lab.
- Never put anything in your mouth while in the lab (including chemicals, solutions, food and drink)
- All food and drinks should be restricted to sitting area only.

13.8 BIBLIOGRAPHY

1. Guidelines for Chemical Laboratory Safety in Secondary Schools. American Chemical Society 1155 Sixteenth Street, NW Washington, DC 20036, 2016.
2. Mobin Shaikh, Laboratory & Chemical Safety Guidelines, Indian Institute of Technology (IIT), Indore.
3. Sudha Goyel, Chemistry Practical-I, Krishna Publication Media (P) Ltd. Meerut, 2017.

UNIT 14 : INORGAIC EXCISE : SALTS MIXTURE ANALYSIS (I & II GROUP)

CONTENTS :

- 14.1 Introduction
- 14.2 Obsective
- 14.3 Inorganic qualitative analysis
- 14.4 Sodium carbonate extract or soda extract
- 14.5 Solubility and solubility product
- 14.6 The common ion effect
- 14.7 Analysis of acidic radicals
- 14.8 Analysis of basic radicals
- 14.9 Experiment-1
- 14.10 Experiment-2
- 14.11 Summary
- 14.12 References
- 14.13 Terminal question

14. 1 INTRODUCTION

Instead, in this lab, you first will perform some preliminary tests using AgNO_3 , BaCl_2 , and H_2SO_4 . In these tests, certain groups of anions will react while other groups of anions will not react. By analyzing the results of the first part of the experiment, you should be able to eliminate half - if not more- of the anions as possibilities in your unknown. You will then perform confirmatory tests for the remaining anions in question to determine whether the anions are present or absent.

The goal of this experiment is to develop techniques for identifying unknown substances. You will identify unknown solutions as containing one of the following: Cl^- , Br^- , I^- , HPO_4^{2-} , or SO_4^{2-} .

The inorganic qualitative analysis involves the identification of ions present in a sample. The salt consists of anion and cation. The basis of identification is the observed chemical behaviour of the components. The salt analysis may be systematically carried out in the following three steps:

- i) Preliminary examination
- ii) Detection of anions and
- iii) Detection of cations

Chemical Analysis Introduction and General Principles Chemical analysis can be defined as the use of a technique or series of operations to recognise and/or quantify a material, identify the constituents of a solution or mixture, or determine the structure of chemical compounds. Chemical analysis is carried out on an unidentified material in two independent steps: 1. Qualitative analysis and Quantitative analysis

1. Qualitative analysis: The sample is determined using qualitative analysis.

2. Quantitative analysis: Quantitative analysis focuses on figuring out the relative proportions of the substance's constituents. Two methods can be used to achieve this:

- (i) Conventional or wet chemical analysis techniques.
- (ii) Analytical tools with instruments.

The foundation of conventional methods is the quantitative execution of suitable chemical processes, which includes measuring the quantity of reagent required to complete the reaction or figuring out the quantity of reaction product formed using techniques like gravimetry, titrimetry, and volumetry. Contrarily, instrumental approaches use numerous techniques

including spectrum methods, electromagnetic methods, separation methods, etc. to quantify a son's physical properties.

14.2 OBJECTIVES

In this unit you will be able to the :

- To use straightforward qualitative chemical tests to detect common anions in solutions.
- Utilise a qualitative analytical method to distinguish between various anion types.
- This experiment aims to identify the anions that are present in an unknown material. Sulphide (S^{2-}), sulphate (SO_4^{2-}), sulfite (SO_3^{2-}), phosphate (PO_4^{3-}), carbonate (CO_3^{2-}), chloride (Cl^-), bromide (Br^-), iodide (I^-), acetate ($C_2H_3O_2^-$), and nitrate (NO_3^-) are frequent anions that we will be searching for.
- To selectively precipitate various cations from aqueous mixtures and use chemical assays to determine their identities.
- To arrange the cation into analytical categories..
- To prepare the solution for cations analysis.
- "Dividing cations into analytical groups."
- Analytical Group I, II, and Zero Group Cation Analysis.

14.3 INORGANIC QUALITATIVE ANALYSIS

The identification of inorganic substances or mixtures of compounds is its main focus. There are two ways it can be done:

1. Dry Technique

2. Wet Method

1. **Dry methods:** When an inorganic substance is discovered via a dry test, we use dry procedures. These techniques produce approximations.

2. **Wet methods:** Wet techniques where identification is carried out using an aqueous solution. The inorganic mixture is often composed of salts that dissociate into positive or cations known as basic radicals and negative or anion known as acid radicals in aqueous solution. The tests performed in solutions are actually examinations of the radicals present there rather than the compounds. These are more useful than dry tests in analysis since they are commonly used, provide accurate data, and do so.

Depending on the amount of material consumed, qualitative analysis can be done on a variety of scales:

- (i) Macro analysis, in which 0.1 to 0.5 g of the drug are taken, together with 10 to 20 ml of the solution.
- (ii) Semi-micro analysis: In this procedure, the quantities are lowered by a factor of 10–20, i.e., only 0.05 g of the drug and 1 ml of the solution are used.

14.4 SODIUM CARBONATE EXTRACT OR SODA EXTRACT

Soda extract, also known as sodium carbonate extract, is a filtrate that can be made by adding three times as much sodium carbonate to distilled water and then heating the combination. For analysis some of the anion, it is ready. The basic radicals of insoluble salts can be determined using the residue that is left over after extracting the substance.

The preparatory process: Take the mixture and put it in a beaker. Add 3 times the amount of solid sodium carbonate and close to 15-20 ml of distilled water, and then boil it for about 15 minutes. Filter it now. Soda extract is the filtrate that was produced. The leftover material could be used to test insoluble basic radicals, particularly radicals of the V group.

Theory: The mixture interacts with excess sodium carbonate, transforming the anion into salts that are soluble in water while the cations become carbonates that are insoluble in water. As a result, after filtration, extract or filtrate contains anion in the form of their water-soluble salts, such as chlorides, nitrates, etc.

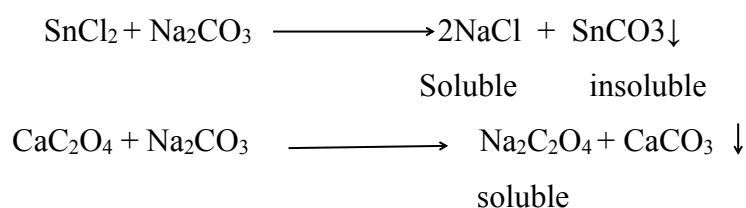

The extract so produced is neutralised with a suitable acid to eliminate any excess Na_2CO_3 that may have remained in solution before being used for the acid radical test. Acid is added until CO_2 bubbles stop erupting, at which point the soda extract has been completely neutralised.

14.4.1 Advantages of preparing and using Soda Extract

1. If the mixture is insoluble in water and dilute acids, it is simpler to identify the acid radicals.

2. By converting basic radicals into their insoluble carbonates, it eliminates them, preventing them from interfering with the methodical examination of acid radicals.
3. In addition, it aids in the detection of basic radicals from compounds that are soluble in mineral acids but not in water, such as radicals from the V group BaSO_4 , SrSO_4 , and CaSO_4 .

14.5 SOLUBILITY AND SOLUBILITY PRODUCT

If a substance dissolves in a solvent, it is referred to as being soluble (more specifically, a solute), and the resulting mixture is known as a solution (it may be unsaturated or saturated). The term "solubility" refers generally to a solute's capacity to dissolve in a solvent. Both the solvent's and the solute's (substance) properties have an impact on solubility. It is more specifically defined as "the amount of the substance dissolved in 100 grammes of the solvent" in a saturated solution at a particular temperature. Temperature and pressure are the main determinants of a solid's solubility in a given solvent, with pressure playing a relatively minor role. For the majority of solids, it rises with rising temperature; for instance, the solubility of AgNO_3 rises quickly while that of NaCl rises slowly. There are some substances, such as Li_2CO_3 , NaOH , etc., whose solubility decreases with increasing temperature.

Solubility curves—which plot the amount of solute dissolved in 100 grammes of solvent along the ordinate versus the temperature along the abscissa—are often used to express how much solubility changes as temperature changes.

14.6 THE COMMON ION EFFECT

The common ion effect is the process by which the concentration of the ion present in the weak electrolyte that is not the common ion is reduced by adding a solution of a strong electrolyte that includes the common ion. For instance, NH_4^+ ions are added to the solution when a strong electrolyte, like $\text{NH}_4\text{Cl} \rightarrow \text{NH}_4^+ + \text{Cl}^-$, is introduced. This occurs when the law of mass action is used, which causes the weak base (electrolyte) NH_4OH to dissociate in solution as $\text{NH}_4\text{OH} \rightarrow \text{NH}_4^+ + \text{OH}^-$. As a result, K is always the same temperature but the concentration of NH_4^+ ions from NH_4Cl and NH_4OH (common ion) rises.

Because of this, the value of $[\text{NH}_4\text{OH}]$ must rise, lowering the value of $[\text{OH}^-]$. This shows that the addition of NH_4Cl , which produces the common ion, NH_4^+ , reduces the degree of

ionisation of NH_4OH . Similar to H_2S , a weak electrolyte, HCl , a strong electrolyte, inhibits the ionisation of H_2S , producing common H^+ ions.

The common ion effect notion is extremely significant in qualitative analysis because it provides a practical method for controlling the concentration of the ions provided by a weak electrolyte. Using H_2S in the presence of HCl to precipitate second group radicals as sulphides is one example, as is using NH_4OH to precipitate fourth group cations as sulphides. Similar to this, when NH_4Cl is available, third group cations can be precipitated as hydroxides using NH_4OH . In the appropriate groups, the details will be discussed.

Complex Formation.

In qualitative analysis, complex ion formation is crucial for two reasons: (i) dissolving a precipitate on its own or from a combination of two or more, and (ii) determining if a certain cation will precipitate through complex ion formation. For instance, (a) AgCl is soluble in ammonia solution because $[\text{Ag}(\text{NH}_3)_2]^+$, a complex ion, forms during the reaction.

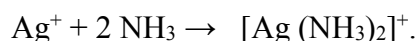

This ability of the Ag^+ ion is used to separate it from the Pb^{2+} and Hg_2^{2+} ions.

For the acidic and basic radicals two type necessary test are required to identify the radicals which are :

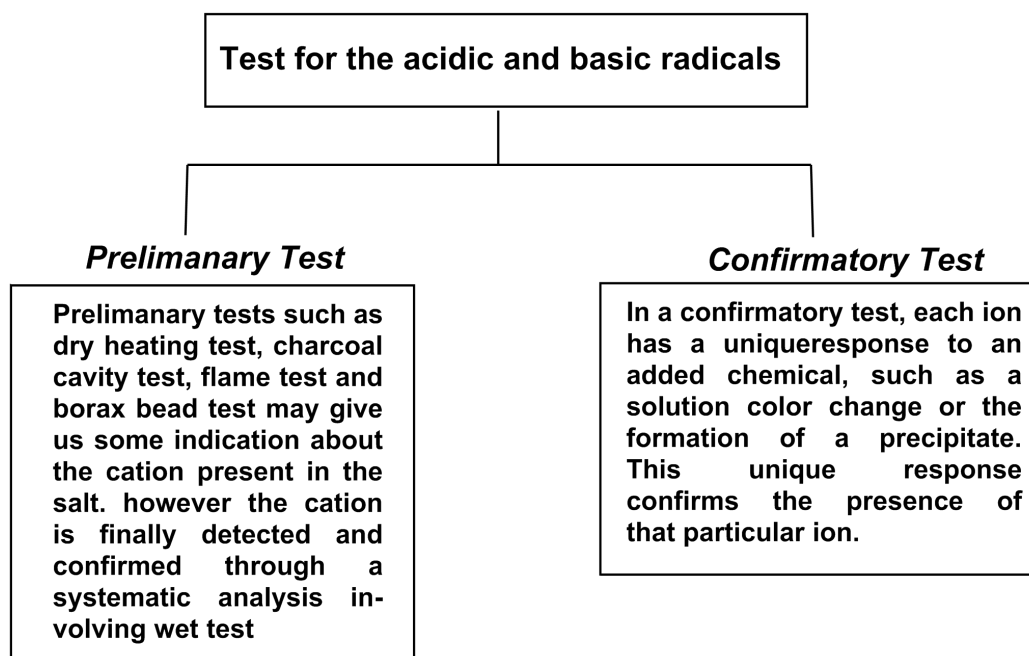

14.7 ANALYSIS OF ACIDIC RADICALS

Any inorganic mixture's entire qualitative examination includes both cation and anion identification. Analysing cations is straightforward because it follows a methodical process, whereas analysing anions requires a little more independence.

It is not only crucial but also vital to identify the acid radicals before analysing the basic radicals because the presence of some acid radicals (interfering radicals) can result in undesirable issues, making their removal at the proper location necessary. We will now talk about each class's analysis separately.

Acids that contain anions (radicals) have a negative charge and are a component of the acid. Acid radicals do not have a systematic group analysis, but they should be studied in the following order to prevent inaccurate results.

Type 1. By dil. H_2SO_4 :

With dil. H_2SO_4 following acid radicals can be analysis and identified.

S.No.	Name of Radicals	Chemical Formula
1	Carbonate	(CO_3^{2-})
2	Nitrite	(NO_2^-)
3	Sulphide	(S^{2-})
4	Sulphite	(SO_3^{2-})
5	Acetate	CH_3COO^-

Type 2. By conc. H_2SO_4 :

With conc. H_2SO_4 following acid radicals give their specific test and hence are identified.

S.No.	Name of Radicals	Chemical Formula
1	Chloride	Cl^-
2	Bromide	Br^-
3	Iodide	I^-
4	Nitrate	NO_3^-
5	Oxalate	$C_2O_4^{2-}$
6	Borate	BO_3^{3-}
7	Fluoride	F^-

Type 3. By specific reagent :

Each radical is identified by specific test.

S.No.	Name of Radicals	Chemical Formula
-------	------------------	------------------

1	Sulphate	SO ₄ ²⁻
2	Phosphate	PO ₄ ³⁻

14.7.1 Preliminary test with dilute H₂SO

Add around 2 ml of dilution H₂SO₄ to a tiny volume of the mixture in the test tube. Take note of the temperature change. Now, gently warm, see the transformation, and take the following conclusions:

S.No.	Experiment	Observation	Inference
1. Test For Carbonate (CO₃²⁻)			
(i)	Preliminary Test : Take small amount mixture in dry test tube and add dil. H ₂ SO	Evolution of colourless of colourless gas with brisk effervescence	Carbonate may be present
(ii)	Pass evolved gas in lime water	It turns milky	CO ₃ ²⁻ may be present
(iii)	Confirmatory Test : If gas is passed for some more time	Turbid lime water again becomes clear solution	CO ₃ ²⁻ confirmed
<p>Carbonate (CO₃²⁻)</p> $\text{Na}_2\text{CO}_3 + \text{H}_2\text{SO}_4 \longrightarrow \text{Na}_2\text{SO}_4 + \text{H}_2\text{O} + \text{CO}_2 \uparrow$ $\text{Ca}(\text{OH})_2 + \text{CO}_2 \longrightarrow \text{CaCO}_3 \downarrow + \text{H}_2\text{O}$ <p style="text-align: center;">White ppt Calcium carbonate</p> $\text{CaCO}_3 + \text{H}_2\text{O} + \text{CO}_2 \xrightarrow{\text{(EXCESS)}} \text{Ca}(\text{HCO}_3)_2$ <p style="text-align: center;">Colourless solution Calcium carbonate</p>			
2. Test for the Sulphite (SO₃²⁻)			
(i)	Preliminary Test : Mixture taken in a dry test tube. The evolution of colourless gas. Then perhaps tube add dil. H ₂ SO ₄ slightly warm.	Evolution of colourless gas with burning sulphur like suffocating smell.	SO ₃ ²⁻ may be present
(ii)	Confirmatory Test : Bring a	Paper turns green	

(i)	Confirmatory Test : In aqueous sol of mixture, neutral FeCl ₃ solution is added.	Blood red colour	CH ₃ COO ⁻ confirmed
(ii)	Take some mixture on your palm add some solid oxalic acid and few drops of water to it and rub with fingers.	Smell like vinegar	CH ₃ COO ⁻ confirmed
<p>4. Acetate (CH₃COO⁻)</p> $2\text{CH}_3\text{COONa} + \text{H}_2\text{SO}_4 \longrightarrow 2\text{CH}_3\text{COOH} + \text{Na}_2\text{SO}_4$ <p style="text-align: center;">Smell of vinegar acetic acid</p> $3\text{CH}_3\text{COONa} + \text{FeCl}_3 \longrightarrow (\text{CH}_3\text{COO})_3\text{Fe} + 3\text{NaCl}$ <p style="text-align: center;">Blood red colour ferric acetate</p>			
<p>5. Test for nitrate (NO₂⁻)</p>			
(i)	Preliminary Test : Take a minimum amount of mixture in dry test tube and add few drop of the dilute H ₂ SO ₄ .	Evolution of brown gas with pungent smell	NO ₂ ⁻ may be present
(ii)	Confirmatory Test : Bring a paper dipped in KI and starch solution in contact of liberated gas at the mouth of test tube.	Paper turns blue.	NO ₂ ⁻ confirmed
<p>5. Nitrite (NO₂⁻)</p> $\uparrow 2\text{NaNO}_2 + \text{H}_2\text{SO}_4 \longrightarrow \text{Na}_2\text{SO}_4 + 2\text{HNO}_2$ $2\text{HNO}_2 \longrightarrow \text{NO} \uparrow + \text{NO}_2 \uparrow + \text{H}_2\text{O}$ $2\text{NO} + \text{O}_2 \longrightarrow 2\text{NO} \uparrow$ <p style="text-align: center;">Brown gas nitrogen dioxide</p>			

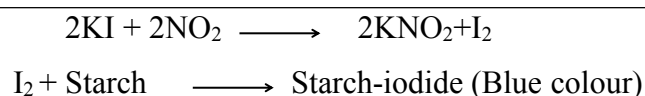

Note : Preparation of neutral FeCl₃ : Take a little amount of FeCl₃ solution (let's say 3 ml) off the shelf and add diluted NH₄OH drop by drop while shaking the test tube until a slight permanent turbidity occurs. Use the filtrate as neutral FeCl₃ after filtering. Normal FeCl₃ solution hydrolyzes and reacts acidically, turning reddish brown:

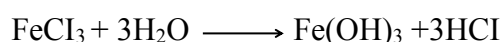

All the above tests can be performed with dilute HCl as well.

14.7.2 Preliminary Test with Conc. H₂SO₄.

Only a few salts cannot be broken down by weak mineral acids; in these cases, concentrated acid is needed. Remember that concentrated acid decomposes salts while diluted acid decomposes salts. Take a tiny bit of the mixture, add 2 ml of concentrated H₂SO₄, and slowly warm. Observe the modifications and conclude the following:

S.No.	Experiment	Observation	Inference
1. Test for chloride Cl⁻			
(i)	Preliminary Test : Take a minimum amount of mixture in dry test tube and add few drop of the conc. H ₂ SO ₄ .	Odourless gas evolves with pungent smell	Cl ⁻ May be present
(ii)	Bring a glass rod dipped in NH ₄ OH in contact of liberated gas at mouth of test tube.	Dense white fumes	Cl ⁻ May be present
(iii)	Heat mixture with MnO ₂ and conc. H ₂ SO ₄	Greenish yellow gas with pungent smell.	Cl ⁻ May be present
Chromyl chloride test			
	Heat little mix in a dry test with 3 times solid vapours K ₂ Cr ₂ O ₇ and conc. H ₂ SO ₄ just to dip	Orange red vapours	Cl ⁻ May be present

	these.		
	Confirmatory Test : Collect red vapours in a test tube having NaOH. Shake well yellow solution add to it CH ₃ COOH and lead acetate.	Yellow precipitate	Cl ⁻ Confirmed
	Take 2cc soda extract in a test tube acidify with dil. HNO ₃ and add AgNO ₃ solution.	White ppt	Cl ⁻ May be present
	Add NH ₄ OH in ppt	ppt dissolves	Cl ⁻ May be present
	Confirmatory Test : Add conc. HNO ₃ into soln.	White ppt eaapeas	Cl ⁻ Confirmed

Chloride Cl⁻

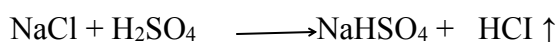

Pungent smell

hydrogen chloride gas

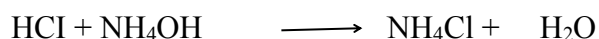

White dense fumes

ammonium chloride

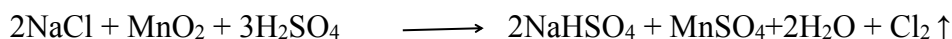

Yellowish green

Chlorine gas

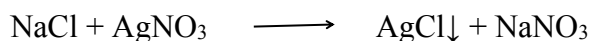

White silver chloride

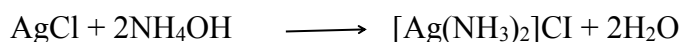

Diammine

silver (1) chloride

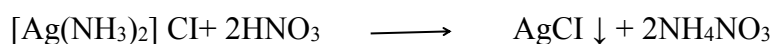

Chromyl chloride test

$4\text{NaCl} + \text{K}_2\text{Cr}_2\text{O}_7 + 3\text{H}_2\text{SO}_4 \longrightarrow 2\text{CrO}_2\text{Cl}_2 + \text{K}_2\text{SO}_4 + 2\text{Na}_2\text{SO}_4 + 3\text{H}_2\text{O}$ <p style="text-align: center;">Chromyl chloride (Red vapour)</p> $\text{CrO}_2\text{Cl}_2 + 4\text{NaOH} \longrightarrow \text{Na}_2\text{CrO}_4 + 2\text{NaCl} + 2\text{H}_2\text{O}$ <p style="text-align: center;">Yellow solution sodium chromate</p> $\text{Na}_2\text{CrO}_4 + (\text{CH}_3\text{COO})_2\text{Pb} \longrightarrow \text{PbCrO}_4 \downarrow + 2\text{CH}_3\text{COONa}$ <p style="text-align: center;">Yellow ppt. lead chromate</p>			
2. Test for the bromide (Br⁻)			
(i)	Preliminary Test : Heat mixture with conc. H ₂ SO ₄ in a dry test tube.	Pungent smelling red brown vapours are evolved.	Br ⁻ may be present
(ii)	Heat mixture with MnO ₂ and conc. H ₂ SO ₄ in a dry test tube.	Pungent smelling red brown vapours are more dense and vigorous.	Br ⁻ may be present.
(iii)	Take approximately 2 ml. soda extract in a test tube, acidify it with dil. HNO ₃ and add AgNO ₃ solution.	Light yellow precipitate	Br ⁻ may be present.
(iv)	Confirmatory Test : Add NH ₄ OH in ppt.	ppt. Partially dissolves	Br ⁻ confirmed
(v)	Take approximately 2 ml soda extract in a test tube acidify it with dil. HNO ₃ , add CCl ₄ (1 ml.) and again add drop by drop Cl ₂ water/dil. HNO ₃ shake well.	CCl ₄ layer turns brown.	Br ⁻ confirmed
2. Bromide (Br⁻)			

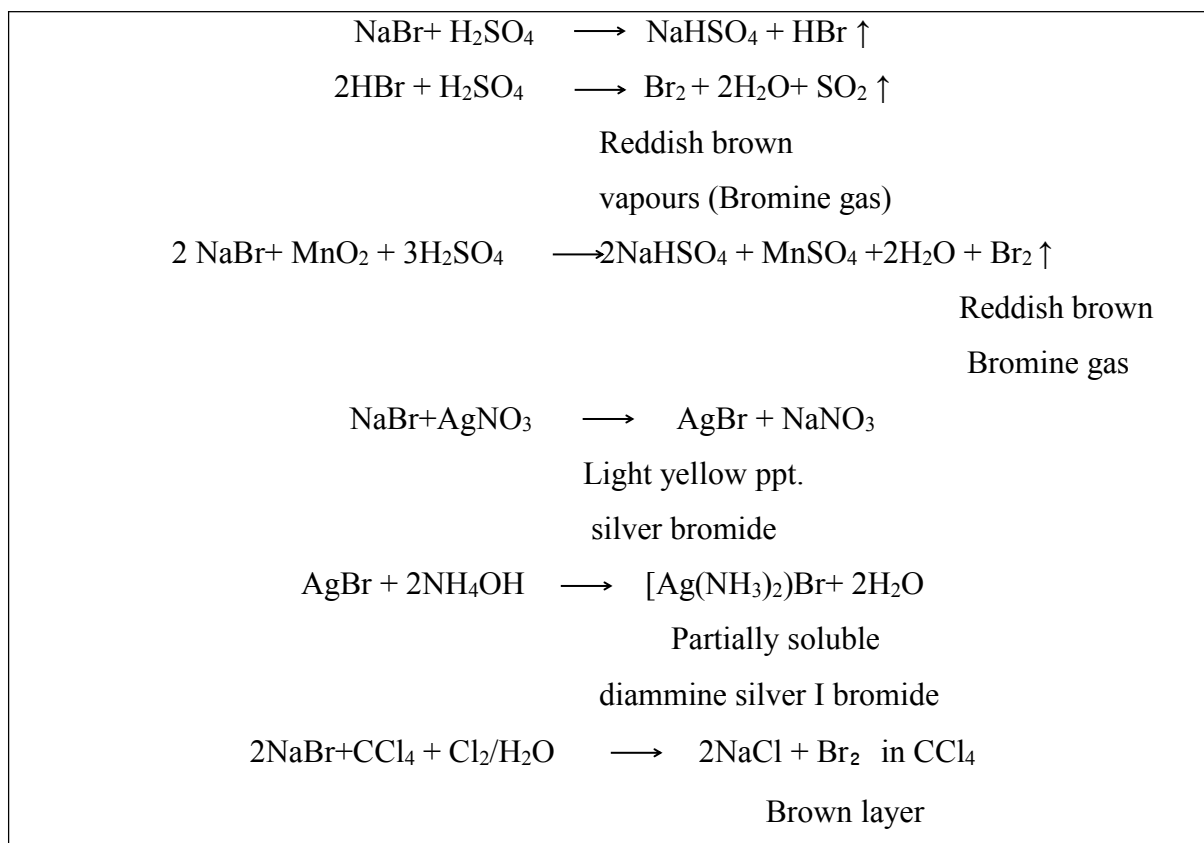

3. Test for iodide (I⁻)

(i)	Preliminary Test :Take a minimum amount of mixture in dry test tube and add few drop of the conc. H ₂ SO ₄ .	Violet vapours are evolved	I ⁻ May be present
(ii)	Heat mixture in a test tube with solid MnO ₂ and conc. H ₂ SO ₄	Dense violet vapours are evolved	I ⁻ May be present
(iii)	Confirmatory Test : Bring a paper dipped in starch in contact of vapours at the mouth of test tube.	Paper turns blue	I ⁻ confirmed.
(iv)	Take 2 ml. soda extract in a test tube acidify it with dil HNO ₃ and add AgNO ₃ solution.	Dark yellow ppt.	I ⁻ May be present
	Add NH ₄ OH in ppt.	ppt. remains insoluble	I ⁻ confirmed.

Layer Test

4. Nitrate (NO₃⁻)

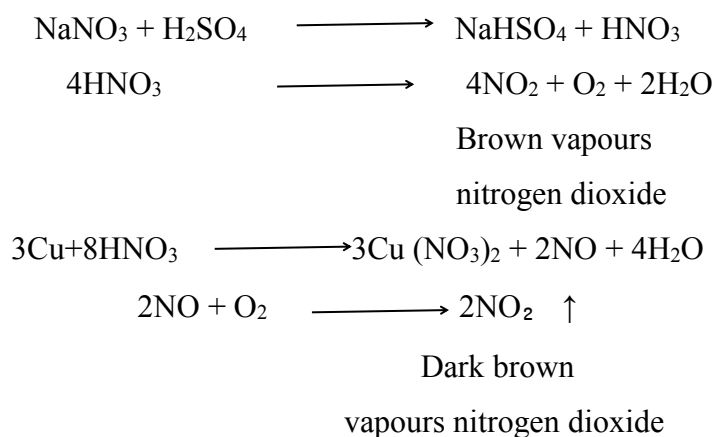

Ring Test

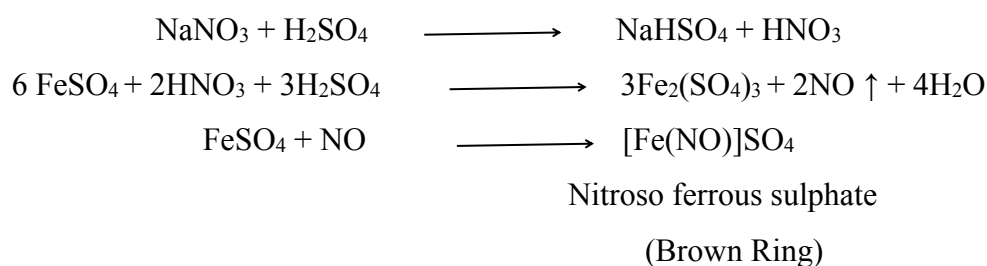

5. Test for oxalate (C₂O₄²⁻)

(i)	Preliminary Test : Take the mixture in a test tube and add few drops of conc. H ₂ SO ₄	Colourless, odourless gas burns with blue flame	C ₂ O ₄ ²⁻ may be present
(ii)	Take 2 ml soda extract in a test tube, acidify it with excess of CH ₃ COOH. Then add CaCl ₂ solution	White ppt	C ₂ O ₄ ²⁻ may be present
(iii)	Confirmatory Test : Now add to it dil. H ₂ SO ₄ . To clear solution add KMnO ₄ Solution.	ppt. Dissolves its colour disappears	C ₂ O ₄ ²⁻ conformed

5. Oxalate (C₂O₄²⁻)

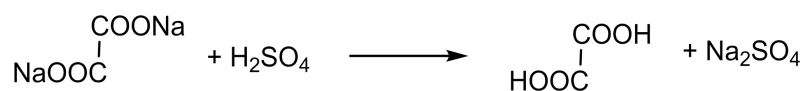

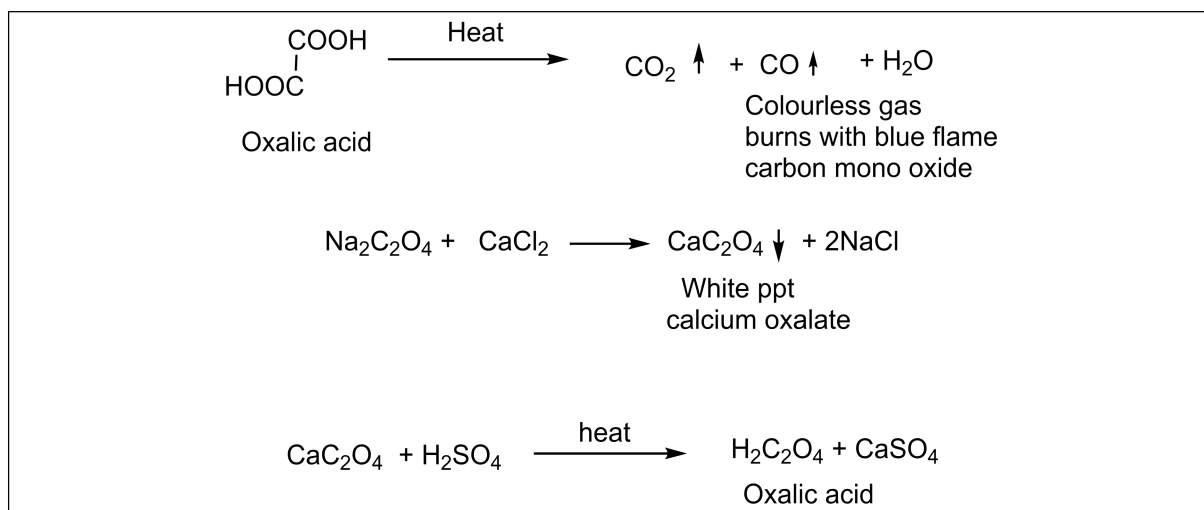

6. Test for the Borate (BO₃³⁻)

(i)	Preliminary Test : Take mixture in a test tube, add to it 2 ml conc. H ₂ SO ₄ and little alcohol and warm. Burn the liberated vapours at the mouth of test tube.	Vapours burn with green edged flame.	BO ₃ ³⁻ may be present
(ii)	Confirmatory Test : In a watch glass or porcelain dish, mix CaF ₂ and mixture in equal amounts and make the thick paste of it with conc. H ₂ SO ₄ . Keep a little paste on the tip of glass rod and bring it close to the flame. confirms borate	Volatile BF ₃ is formed and flame appears green	BO ₃ ³⁻ confirmed

6. Borate (BO₃³⁻)

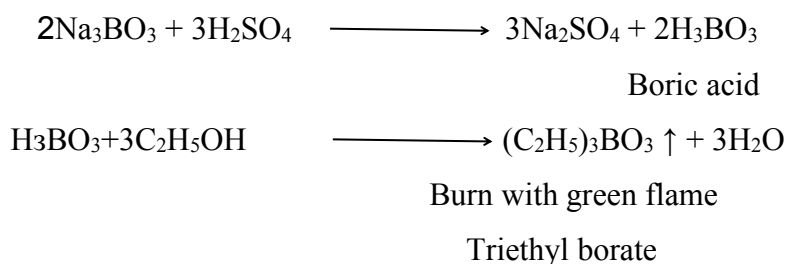

7. Test for fluoride (F⁻)

(i)	Preliminary Test : Take the	Colourless pungent	F ⁻ May be present
-----	------------------------------------	--------------------	-------------------------------

	mixture in a test tube and add few drops of conc. H ₂ SO ₄ .	smelling fumes. The test tube becomes greasy	
(ii)	Confirmatory Test : Heat the mixture after adding 2 ml of concentrated H ₂ SO ₄ and some sand to it in a test tube. Bring a glass rod that has been wetted with water in contact with the vapours at the test tube's mouth.	A waxy white deposit on glass rod and sides of test tube becomes oily.	F ⁻ confirmed

7. Fluoride

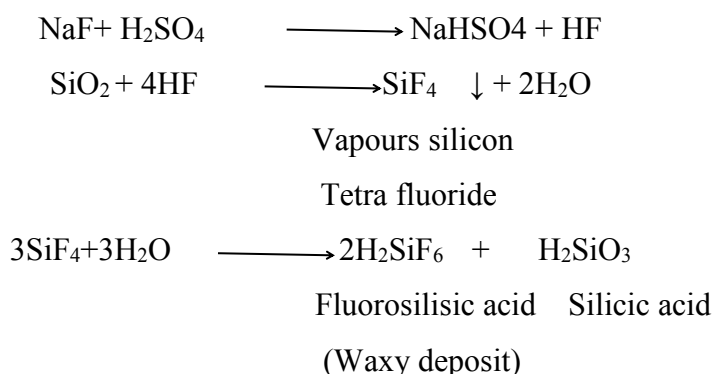

Type 3. acidic radicals giving test with specific reagent

S.No.	Experiment	Observation	Inference
1. Test for sulphate (SO₄²⁻)			
(i)	Preliminary Test : Soda extract, acidify with dil. HCl, add BaCl ₂ solution.	White ppt	SO ₄ ²⁻ may be present
(ii)	Confirmatory Test : Add in the same test tube conc. HCl	ppt. Does not dissolve	SO ₄ ²⁻ Confirmed
1. Sulphate (SO₄²⁻)			
$\text{NaSO}_4 + \text{BaCl}_2 \longrightarrow \text{BaSO}_4 \downarrow + 2\text{NaCl}$ <p style="text-align: center;">White ppt</p>			

2. Test for the Phosphate (PO ₄ ³⁻)			
(i)	Preliminary Test : Heat the mixture in a test tube with conc. HNO ₃ then add ammonium molybdate solution and again warm	Canary yellow ppt	PO ₄ ³⁻ may be present
(ii)	Confirmatory Test : Boil soda extract in a test tube with 2cc conc. HNO ₃ , add ammonium molybdate solution.	Canary yellow ppt appears	PO ₄ ³⁻ confirmed
<p>2. Phosphate (PO₄³⁻)</p> $\text{Na}_3\text{PO}_4 + 3\text{HNO}_3 \longrightarrow 3\text{NaNO}_3 + \text{H}_3\text{PO}_4$ $\text{H}_3\text{PO}_4 + 12 (\text{NH}_4)_2\text{MoO}_4 + 21 \text{HNO}_3 \longrightarrow (\text{NH}_4)_3\text{PO}_4 \cdot 12\text{MoO}_3 \downarrow + 21\text{NH}_4\text{NO}_3 + 12 \text{H}_2\text{O}$ <p style="text-align: center;"> Ammonium molybdate Canary yellow ppt. Ammonium phosphomolybdate </p>			

14.8 ANALYSIS OF BASIC RADICALS

An ion originating from a base is known as a basic radical. It is a chemical species that contains a positive charge. Thus, it is also known as a cation. This ion is formed by removing the hydroxide ion from its base.

14.8.1 Step used for the analysis of basic radicals

Wet test wet group analysis is used to determine basic radicals. The steps involved in analysis are:

- First, the mixture's original solution (OS) is made.
- The group is then precipitated from the original solution using an appropriate group reagent.
- The group's precipitate is divided by filtration, and each radical in the group is examined and confirmed using tests tailored to that radical's nature.

- It is not rejected to filtrate. The filtrate from the prior group is tested on the following group until the necessary (3 or 4) basic radicals are obtained.

14.8.2 Preparation of the Original solution (OS)

It can be made by dissolving the combination in an appropriate solvent in accordance with the instructions.

1. Filtered water

2. Hydrochloric acid, diluted

3. Hydrochloric acid (Conc. HCl)

4. Aqua regia (conc. HCl in 3 parts plus 1 part of conc. HNO₃)

(i). Bring a small mixture of water to a boil while vigorously shaking. If the combination does not dissolve then, it is utilised as OS if it dissolves.

(ii). Heat mixture with dilute HCl and vigorously stir; use only if it dissolves. The absence of the 1st group in the combination is indicated by OS and the mixture's dissolution in dil. HCl.

(iii). Place the mixture in a test tube and boil it with concentrated H₂SO₄ for 4-5 minutes if it is still insoluble in dilute HCl. If it dissolves, dilute it with water and re-boil the mixture to create a clear solution. In the majority of applications, OS mixture is soluble in concentrated HCl.

14. 8.3 Group separation

The flow-sheet given below reveals in brief the total procedure of cationic separation. NH₄⁺ is tested from original solution.

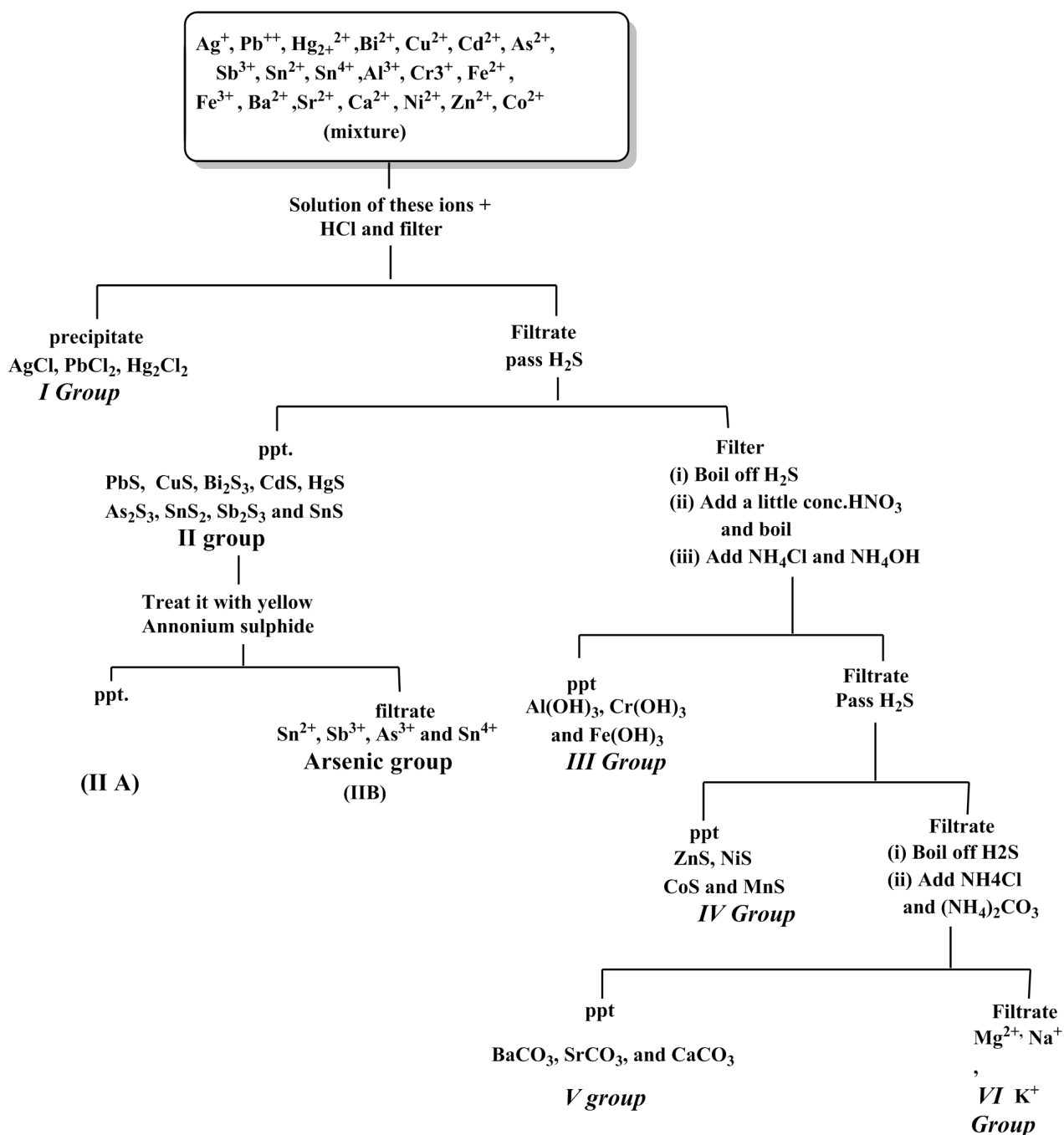

(iv) If the combination is intractable even in concentrated HCl, aqua regia is used to dissolve it. a combination of 3 parts concentrated HCl and 1 part concentrated HNO₃. In this instance, the mixture is cooked in a china dish with aqua regia until all of the acid has evaporated. The leftover material dissolves in water.

Based on reagent and solubility product, all radicals are categorised into seven classes. A reagent that keeps the radicals that are precipitated by the same chemicals together is known as a group reagent. Ammonium NH₄⁺ radicals cannot be grouped, hence they are retained in the zero group.

This analysis, unlike the analysis of acid radicals, necessitates the creation of the original mixture's solution. This is mostly due to the fact that, after the solution is created, it can be subjected to numerous modifications that induce some ions of a particular kind to precipitate simultaneously while others do so sequentially. In this manner, we create six groups for the examination of cations. True solutions have the following qualities:

1. It should be transparent and free of any combination particles that could be seen. Of fact, depending on the ions present, this might have any colour.
- 2.2 This must not undergo sedimentation, meaning that none of its components should condense on the vessel's bottom.

The flow chart provided below provides a concise overview of the entire cationic separation process. From the initial solution, NH_4^+ is tested.

Point to be noted

- Group reagents are sequentially added to the initial solution in order to precipitate a group, beginning with the first group and continuing until ppt in the group is reached. Ppt. formation indicates the presence of one or more radicals in the group. Before moving on to the next group, complete precipitation of the previous group must be ensured by adding excess group reagent; otherwise, there may be a considerable interruption in the routine examination of the following group radicals.
- If the volume of the solution becomes too large, it is reduced to a tolerable quantity by evaporation in a china dish rather than being discarded.

<i>Group</i>	<i>Group reagent</i>	<i>Basic radicals</i>	<i>Precipitated as their (salt present)</i>
Zero	dil. Sodium hydroxide	NH_4^+	-
First I st	Dil. HCl	Pb^{2+} , Ag^+ , Hg_2^{2+}	Chlorides
Second II nd	H_2S gas in the presence of dil. HCl	Pb^{2+} , Hg^{2+} , Bi^{3+} , Cu^{2+} , Cd^{2+} , As^{3+} , Sb^{3+} , Sn^{4+} , Sn^{2+}	Sulphides
Third III rd	NH_4OH in the presence NH_4Cl	Fe^{3+} , Al^{3+} , Cr^{3+}	Hydroxides
Fourth IV th	H_2S gas in the presence of NH_4OH and NH_4Cl	Zn^{2+} , Mn^{2+} , Ni^{2+} , Co^{2+}	Sulphides
Fifth V th	$(\text{NH}_4)_2\text{CO}_3$ in the presence	Ba^{2+} , Sr^{2+} , Ca^{2+}	Carbonate

	of NH_4OH and NH_4Cl		
Sixth VI th	Disodium hydrogen phosphate in presence of NH_4OH	Mg^{2+}	Ammonium Phosphate

The method used to separate the all the basic radicals from their respective group by step by step by following manner which illustrate as :

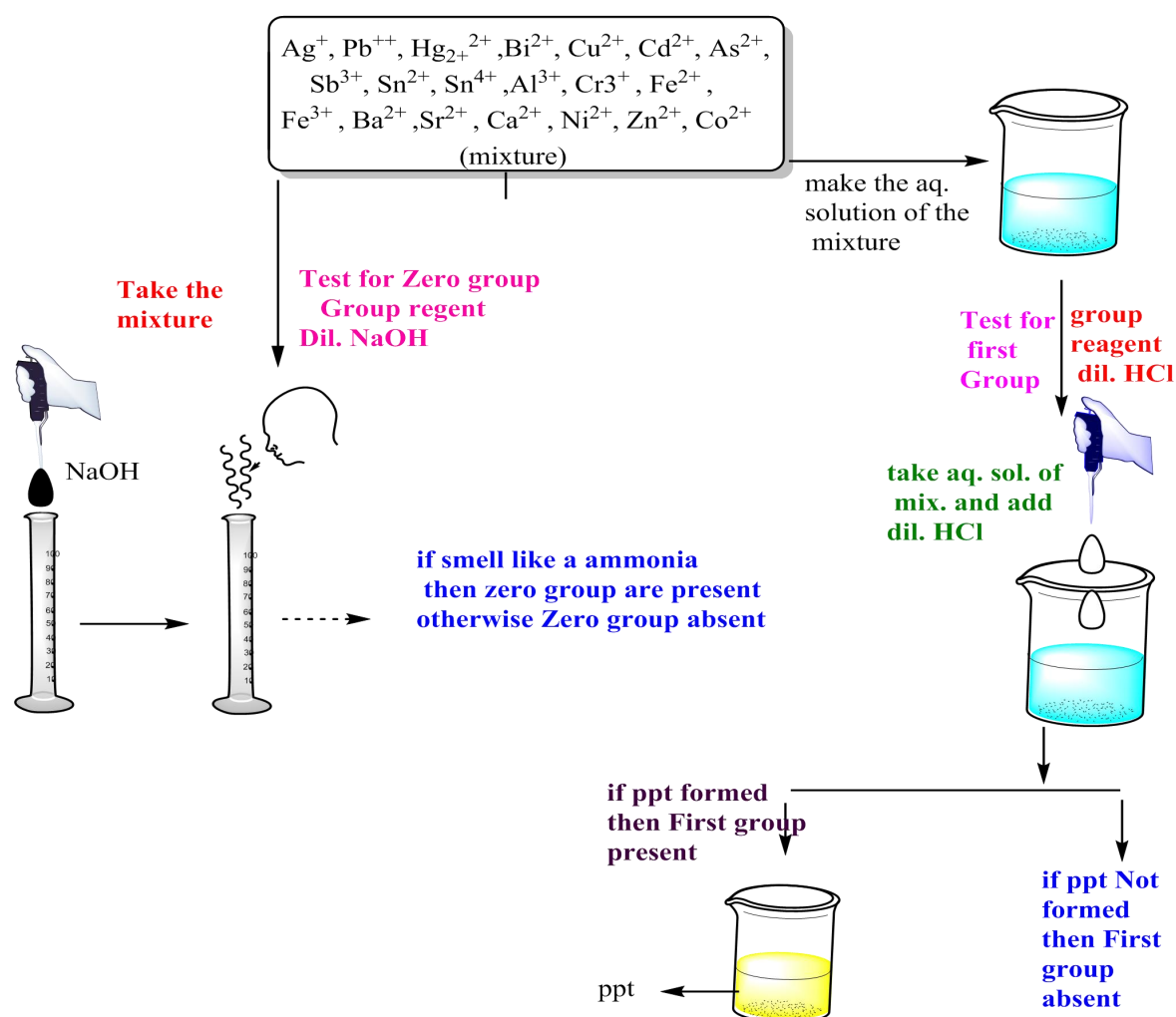

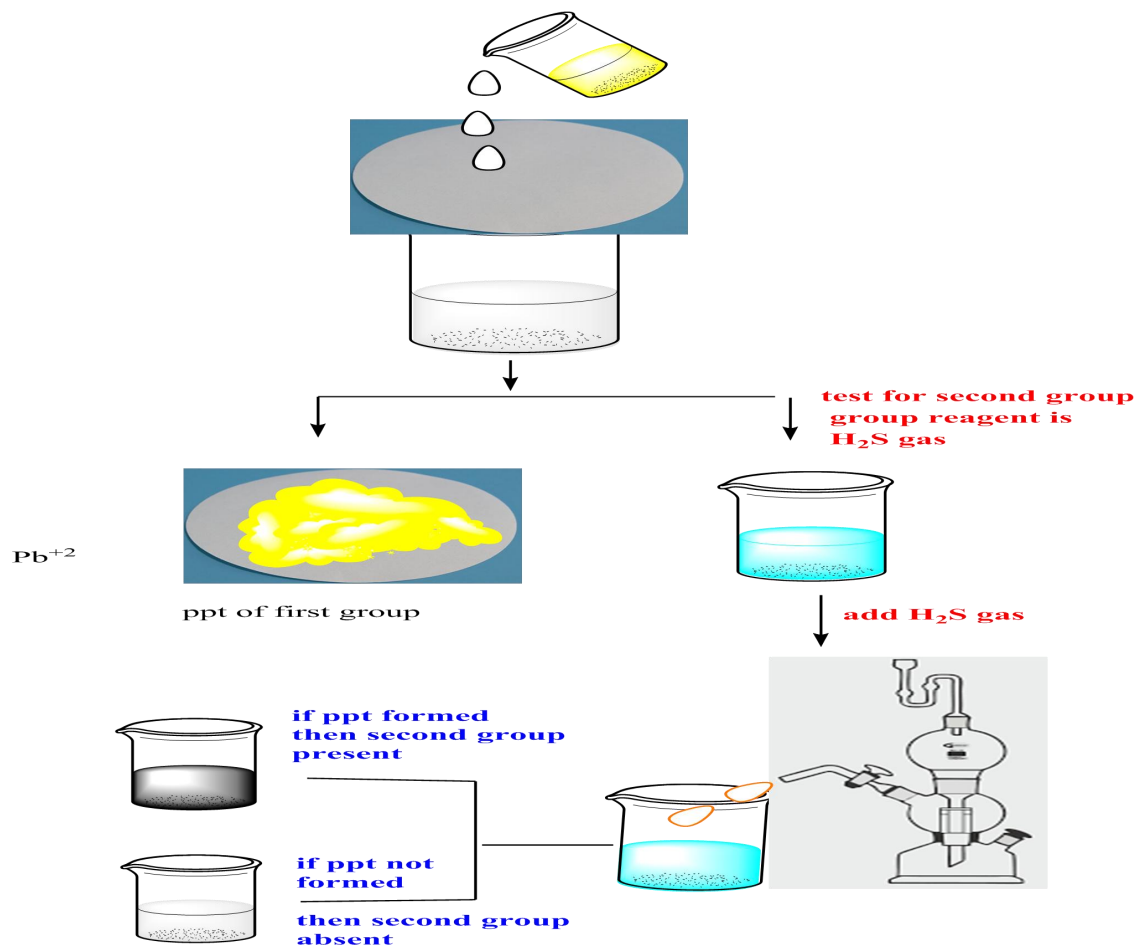

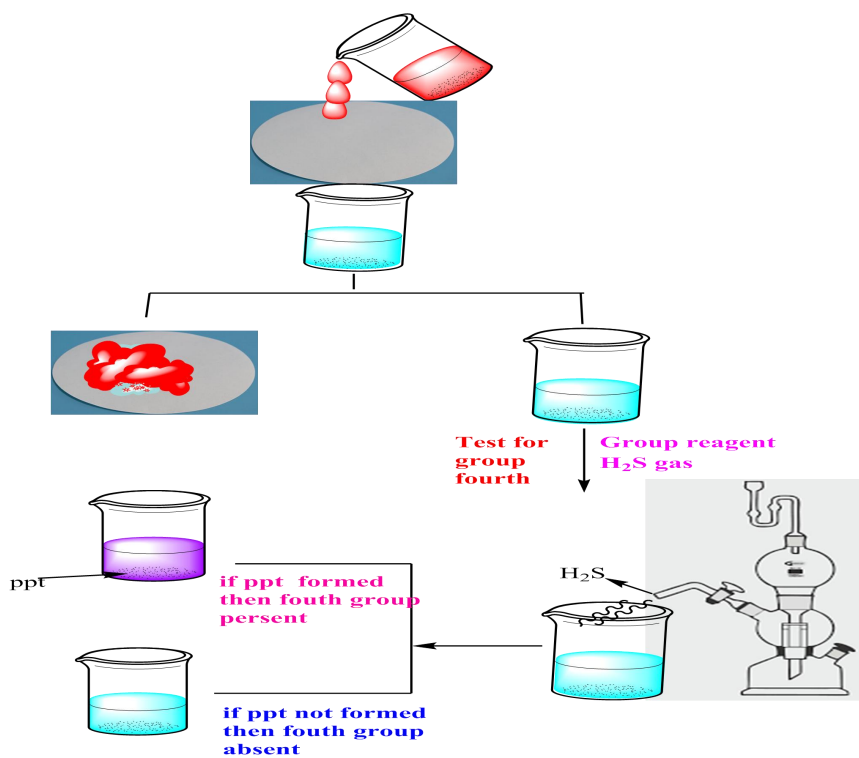
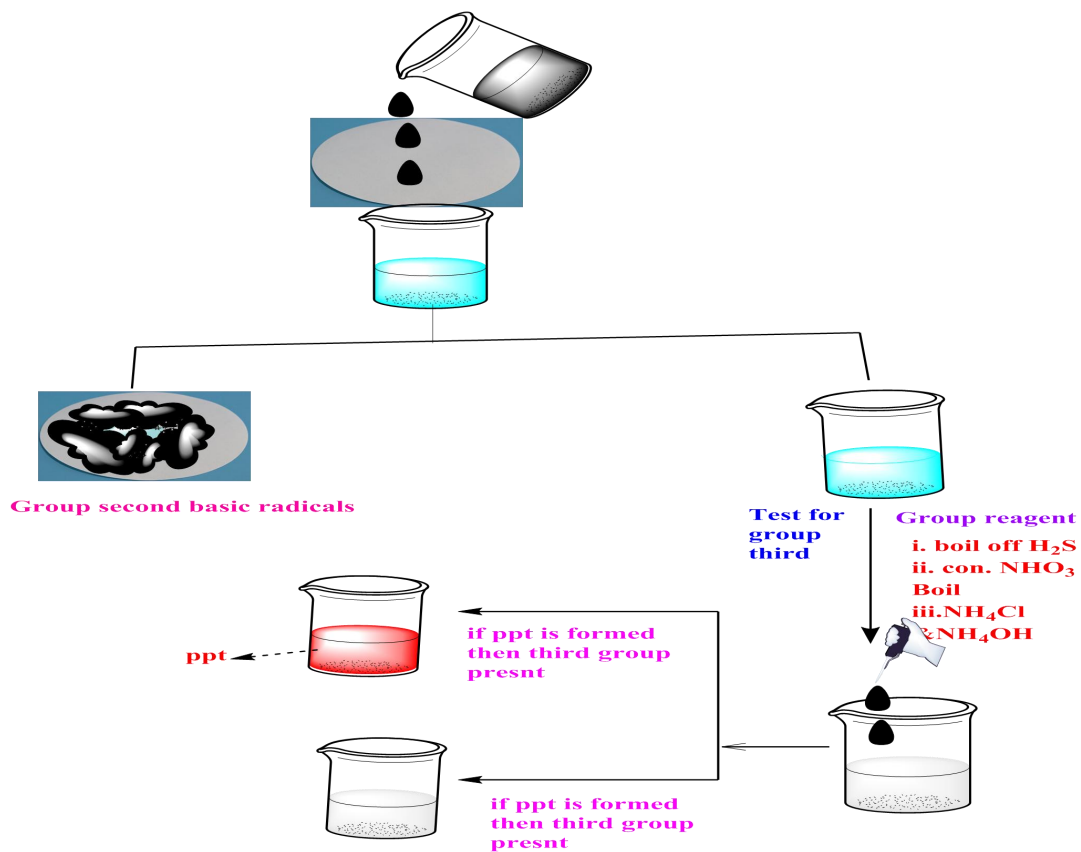

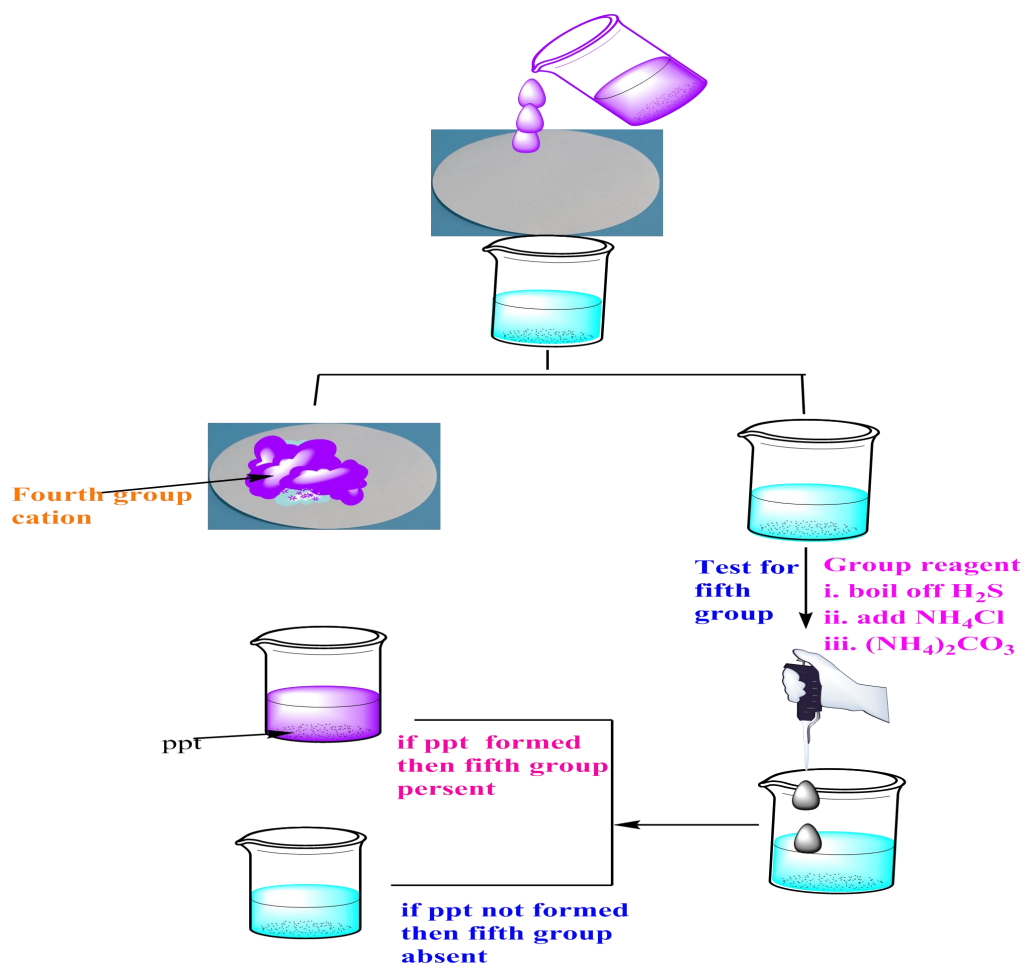

14.8.3 Analysis of Zero group

S. No.	Experiment	Observation	Inference
(i)	Heat mixture in a test tube with dil. NaOH	Evolved gas has smell of ammonia	NH_4^+ may be present
(ii)	Bring a glass rod dipped in conc. HCl at the mouth of test tube	White dense fumes of NH_4Cl	NH_4^+ Confirmed
(iii)	Add Nessler reagent in the aqueous solution of mixture	Brown colour or precipitate	NH_4^+ Confirmed

Nessler Reagent: This is made by mixing KI into a solution of HgCl_2 . The orange ppt of HgI_2 is first obtained. Once the ppt dissolves and a clear solution is obtained, add more KI. Add NaOH to it. This mixture is referred to as Nessler's reagent; it is a very specific reagent for testing the presence of ammonium radical in the mixture and yields positive results even when just a little amount of the NH_4^+ radical is present in the solution.

NH₄⁺ Radical

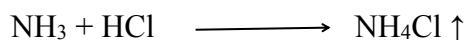
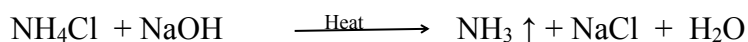

White fumes
ammonium chloride

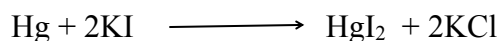

Orange ppt

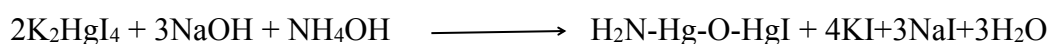

Iodide browns

14.8.4 Analysis of First group

Radicals : Ag⁺, Pb²⁺, Hg₂²⁺

Group Reagent : dil. HCl

Precipitate Formed : white ppt. of AgCl, PbCl₂, Hg₂Cl₂

Method: Take cold original solution in a test tube add to it dil. HCl; if white pa is formed then add dil. HCl in excess for complete precipitation. Precipitate separated by filtration and filtrate is kept for the analysis of II and other groups.

Note: If original solution is prepared in dil. HCl. I group is automaticall absent.

Precipitate is taken in a test tube and boiled with H₂O, if all ppt. dissolves Ag and Hg₂²⁺ are absent and in solution Pb²⁺ is tested. If some ppt. is there filter and proceed as below.

Filterate	Residue	
Pb ²⁺ As PbCl ₂ Divide filterate into 3 parts	Ag ⁺ , Hg ₂ ²⁺ Shake the residue with NH ₄ OH and filter	
1. 1 st part cool it → Shining crystals Pb ²⁺ confirm. 2. In II nd part add KI solution ; yellow ppt of PbI ₂ is obtained Pb ²⁺ confirm.	Filterate	Residue
	Ag ⁺ As [Ag(NH ₃) ₂]Cl divide it into 3 parts :	Hg ₂ ²⁺ As Hg + HgNH ₂ Cl evaporate ppt with aquaregia in a chaina dish then extract residue with hot water and divide into two part.

<p>3. In IIIrd part add K₂CrO₄ solution : yellow ppt. of PbCrO₄ is obtained Pb²⁺ confirm.</p>	<p>1. In Ist part add dil. HNO₃, white ppt. appears Ag⁺ confirm. 2. In IInd part add CH₃COOH and K₂CrO₄. Red ppt. will form, Ag⁺ confirm. 3. In IIIrd part add KI yellow ppt. will appear. Ag⁺ confirm.</p>	<p>1. In Ist part add SnCl₂, white or grey ppt will form. 2. To IInd part Cu turning are added white deposit on Cu turning confirm Hg₂²⁺.</p>
--	---	---

Lead (Pb²⁺)

White

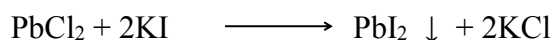

White ppt

Lead iodide

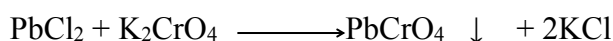

Yellow ppt.

lead chromate

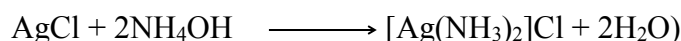
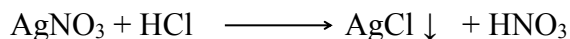
Silver (Ag⁺)

Soluble diammine

Silver I chloride

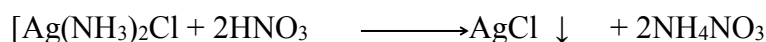

White ppt

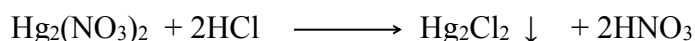
Mercurous (Hg₂²⁺) :

White ppt.

Mercurous chloride



Black

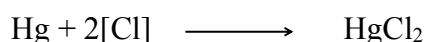
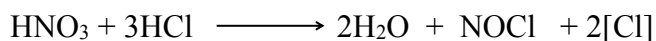

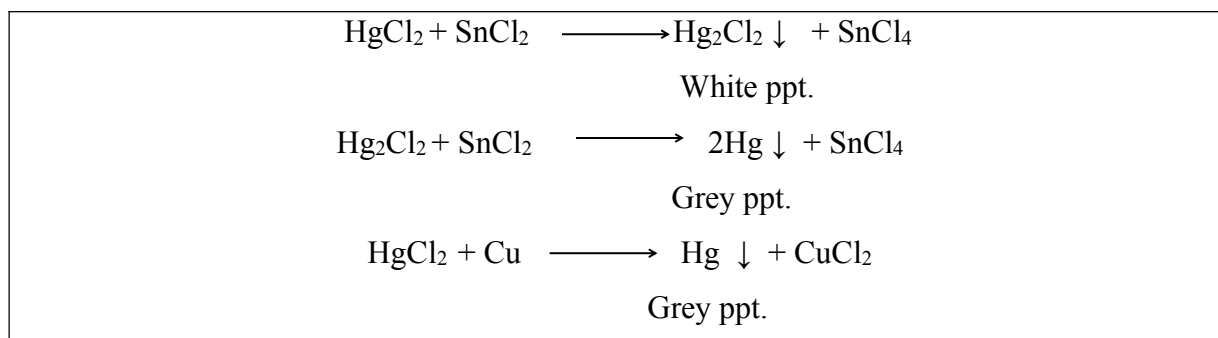

14.8.5 Analysis of Second (II) group

Second group is divided into two sub-groups:

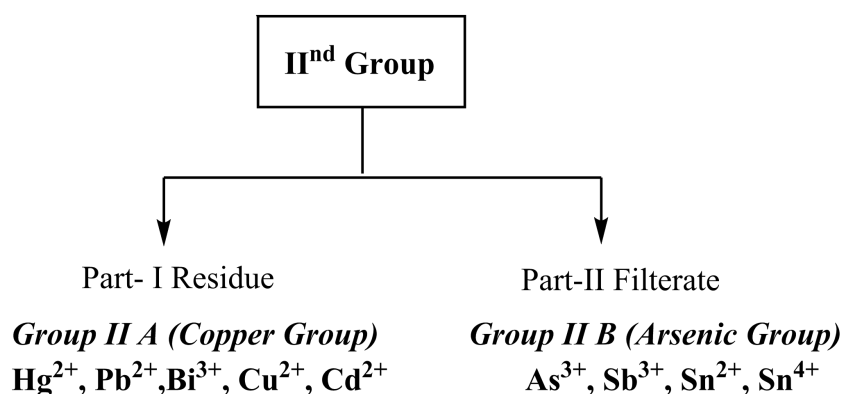

14.8.5.1 Group Reagent : H₂S gas in the Presence of dil. HCl

14.8.5.2 How to prepared Hydrogen sulfide(H₂S gas)

- I. Hydrogen sulphide (H₂S) has the repulsive scent of rotten eggs and is colourless, highly corrosive, combustible, and toxic.
- II. It can be made by heating two parts paraffin wax and one part sulphur to a temperature exceeding 160 °C.
- III. The reaction mixture must not be heated over 200°C because doing so will cause the tubes to get clogged with paraffin vapour.
- IV. When broken particles of iron sulfide (FeS) placed in the Kipps apparatus come into contact with diluted HCl or sulfuric acid, hydrogen sulphide (H₂S) can also be formed.

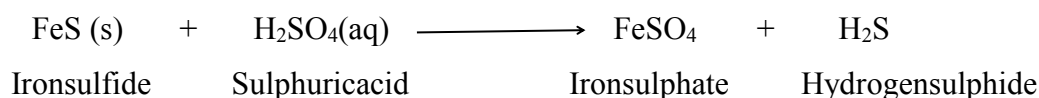

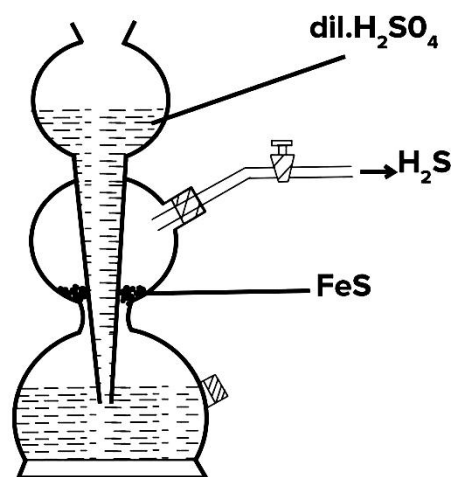

Kipp's apparatus

14.8.5.3 Precipitate

Black-Grey - HgS , PbS , Bi_2S_3 , CuS , SnS

Yellow - CdS , As_2S_3 , SnS_2

Orange - Sb_2S_3

14.8.5.4 Analytical procedure:

First group filtrate should be warmed, diluted with water, and then H_2S gas should be passed through it for 1 minute if ppt does not form. If the second group does not form, it is considered that the speaker is not present. The full filtrate from the first group is passed if ppt. happens. The precipitate is separated by filtration and then thoroughly washed with water. The filtrate is kept for analysis by the III Group. Filtration is performed after a test tube containing washed precipitate has been filled and warmed with a small amount of yellow ammonium sulphide solution.

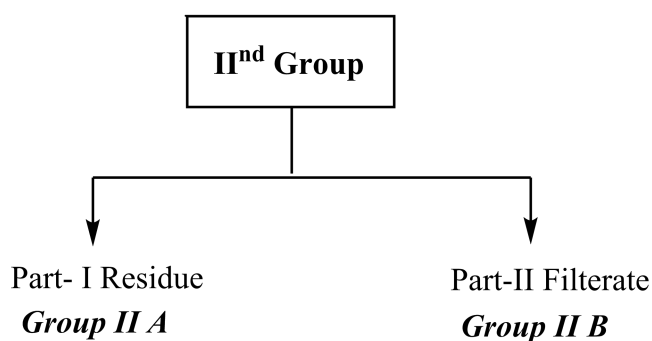

14.8.5.5 analysis of II A Group

Residue is washed with water and boiled with 50% conc. HNO_3 if all dissolves Hg is taken absent otherwise filter it.

Black residue (HgS)	Filterate	
Dissolve it in aqua regia, then evaporate to dryness in a china dish, extract residue with water and divide in two parts	May contain nitrates of Pb, Cu, Bi or Cd Take some portion of filterate and add it dil. H ₂ SO ₄ : (a) If white ppt appears add dil. H ₂ SO ₄ on presence of ethyl Alcohol in all filterate → white ppt. Of PbSO ₄ and then filter it. (b) If white ppt. Does not appear- Pb ²⁺ is taken as absent	
(i) Add in Ist Part SnCl ₂ → White or grey ppt. Hg ²⁺ confirmed (ii) Add Cu turning to IInd part → Grey deposit-on Cu turning		
<p>Mercuric (Hg²⁺)</p> $\text{HgCl}_2 + \text{H}_2\text{S} \longrightarrow \text{HgS} \downarrow + 2\text{HCl}$ $3\text{HgS} + 2\text{HNO}_3 + 6\text{HCl} \longrightarrow 3\text{HgCl}_2 + 2\text{NO} \uparrow + 3\text{S} \downarrow + 4\text{H}_2\text{O}$ $2\text{HgCl}_2 + \text{SnCl}_2 \longrightarrow \text{Hg}_2\text{Cl}_2 \downarrow + \text{SnCl}_4$ <p style="text-align: center;">White ppt</p> $\text{Hg}_2\text{Cl}_2 + \text{SnCl}_2 \longrightarrow 2\text{Hg} \downarrow + \text{SnCl}_2$ <p>Lead (Pb²⁺)</p> $\text{PbCl}_2 + \text{H}_2\text{S} \longrightarrow \text{PbS} \downarrow + 2\text{HCl}$ <p style="text-align: center;">Black ppt.</p> $3\text{PbS} + 8\text{HNO}_3 \longrightarrow 3\text{Pb}(\text{NO}_3)_2 + 2\text{NO} \uparrow + 3\text{S} \downarrow + 4\text{H}_2\text{O}$ $3\text{Pb}(\text{NO}_3)_2 + \text{H}_2\text{SO}_4 \longrightarrow \text{PbSO}_4 \downarrow + 2\text{HNO}_3$ $\text{PbSO}_4 + 2\text{CH}_3\text{COONH}_4 \longrightarrow (\text{NH}_4)_2\text{SO}_4 + (\text{CH}_3\text{COO})_2\text{Pb}$ $(\text{CH}_3\text{COO})_2\text{Pb} + \text{K}_2\text{CrO}_4 \longrightarrow 2\text{CH}_3\text{COOK} + \text{PbCrO}_4 \downarrow$ <p style="text-align: center;">Yellow ppt.</p> <p>Bismuth (Bi³⁺)</p> $2\text{BiCl}_3 + 3\text{H}_2\text{S} \longrightarrow \text{Bi}_2\text{S}_3 + 6\text{HCl}$ $\text{Bi}_2\text{S}_3 + 8\text{HNO}_3 \longrightarrow 2\text{Bi}(\text{NO}_3)_2 + 2\text{NO} \uparrow + 3\text{S} \downarrow + 4\text{H}_2\text{O}$		

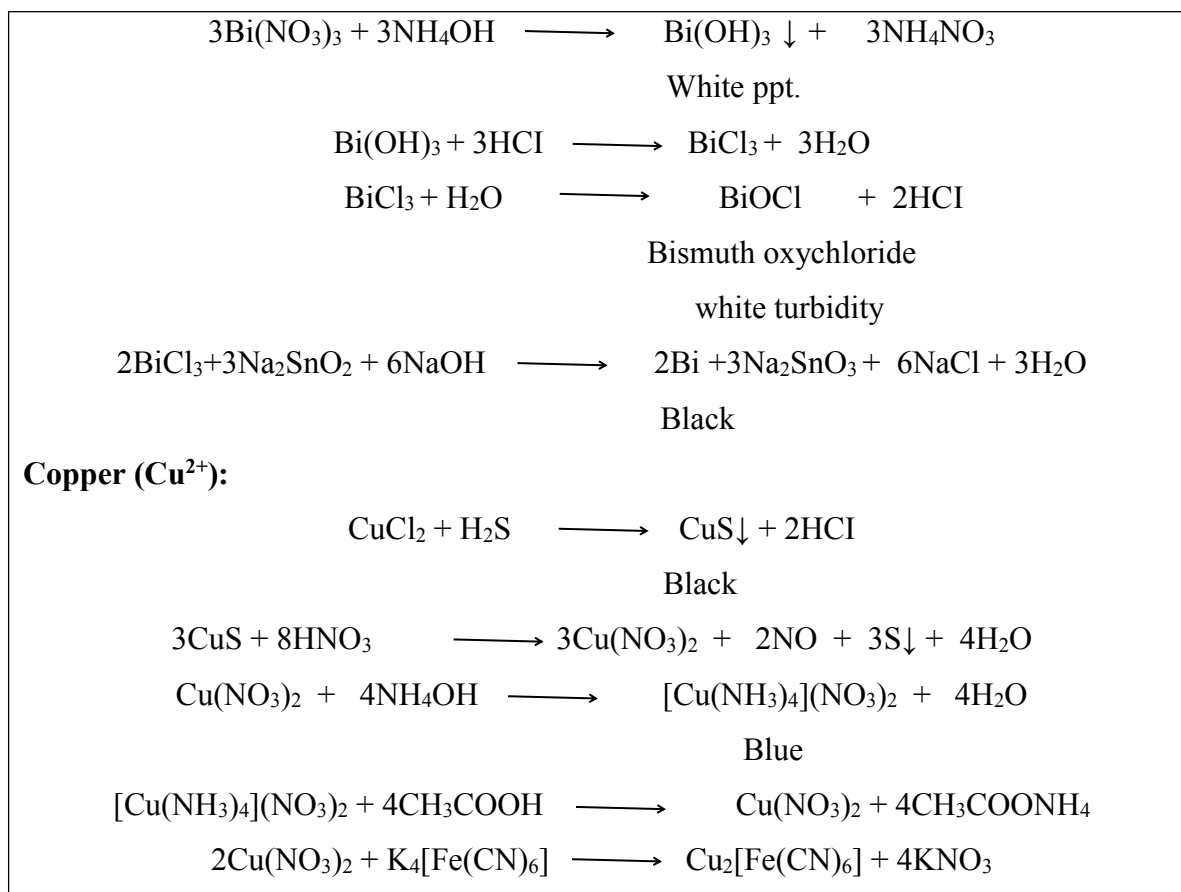

Black residue(HgS)	Filterate	
Dissolve it in aqua regia, then evaporate to dryness in a china dish, extract residue with water and divide in two parts	May contain nitrates of Pb, Cu, Bi or Cd Take some portion of filterate and add it dil.H ₂ SO ₄ : (c) If white ppt appears add dil. H ₂ SO ₄ on presence of ethyl Alcohol in all filterate \longrightarrow white ppt. Of PbSO ₄ and then filter it. (d) If white ppt. Does not appear- Pb ²⁺ is taken as absent	
(iii) Add in Ist Part SnCl ₂ \longrightarrow White or grey ppt. Hg ²⁺ confirmed (iv) Add Cu turning to IInd part \longrightarrow Grey deposit-on Cu turning Hg ²⁺ confirm	Residue may have PbSO ₄ . Dissolve residue in conc. Solution of ammonium acetate and add K ₂ CrO ₄ \downarrow Yellow ppt. Pb ²⁺	It may have sulphates or nitrates of Bi, Cu and Cd. add into this excess of NH ₃ and filter.

	confirmed	
	<p>White ppt It may have Bi(OH)₃. Dissolve it in minimum amount of conc. HCl and divide in 2 parts.</p> <p>(i) First part dilute with water white turbidity.</p> <p>(ii) Add sodium stannite solution to 2nd part ↓ Black ppt. Bi³⁺ confirmed</p>	<p>If filtrate is blue it has copper and if colourless copper is taken absent filtrate divided into 2 parts. Their tests can be done in 3 ways :</p> <p>First Method :</p> <p>(i) Take filtrate add to it CH₃COOH and chocolate ppt. Cu²⁺ confirmed.</p> <p>(ii) To 2nd part of filtrate, KCN solution is added till blue colour disappears then H₂S gas is passed-yellow ppt. Cd²⁺ confirmed</p>
	<p>Note Sodium stannite is prepared by adding excess of NaOH to SnCl₂ solution till ppt. formed dissolves.</p>	
	<p>Second method for test of copper and cadmium</p>	
	<p>Add in filtrate conc. HCl and pass H₂S gas and filter.</p>	
	<p>Black residue copper confirmed.</p>	<p>Filter dilute it with water and again pass</p>

		H ₂ S gas ↓ Yellow ppt Cd ²⁺ confirmed
	Third Method	
	Add in filtrate 5cc conc. HCl and FeSO ₄ solution and filter.	
	Residue copper confirmed.	Filtrate dilute it with water and pass H ₂ S gas → yellow ppt Cd ²⁺ confirmed
<p>Cadmium (Cd²⁺)</p> $\text{CdCl}_2 + \text{H}_2\text{S} \longrightarrow \text{CdS} \downarrow + 2\text{HCl}$ <p style="text-align: center;">Yellow</p> $3\text{CdS} + 8\text{HNO}_3 \longrightarrow 3\text{Cd}(\text{NO}_3)_2 + 2\text{NO} \uparrow + 3\text{S} \downarrow + 4\text{H}_2\text{O}$ $\text{Ca}(\text{NO}_3)_2 + 4\text{NH}_4\text{OH} \longrightarrow [\text{Cd}(\text{NH}_3)_4](\text{NO}_3)_2 + 4\text{H}_2\text{O}$		

14.8.6. Analysis of II B Group

Take filtrate left after separating IIA group, add dil. HCl in it in excess. Formation of coloured precipitate indicates II B group but if no ppt. is formed or white ppt. appears it is taken as absence of II B group. Filter it, take ppt. and boil with conc. HCl and filter.

Yellow residue	Filtrate
As ₂ S ₃ Dissolve ppt. in conc. HNO ₃ and add ammonium molybdate and heat Yellow ppt formed → As ³⁺ confirmed.	It may contain chlorides of Sb and Sn. These can be confirmed by either of the two methods.
	First Method Make the filtrate just alkaline by adding NH ₄ OH solution.

	Add 1-2 g. Solid oxalic acid, boil and pass H ₂ S gas. Filter if ppt. Appears.	
	Orange Residue	filtrate
	Sb ³⁺ Dissolve ppt. in conc. HCl and dil. with water. White turbidity appears. Sb ³⁺ confirmed.	May have Sn ⁴⁺ To filtrate add NH ₄ OH and pass H ₂ S gas ↓ Dirty yellow ppt. Sn ⁴⁺
	Second Method In the filtrate add iron-filling boil for 5 minutes.	
	Black residue	filtrate
	Sb ³⁺ Sb ³⁺ confirmed	May contain SnCl ₂ in filtrate add HgCl ₂ solution. ↓ White or grey ppt. Sn ²⁺ confirmed

Arsenic (As³⁺)

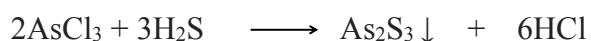

Yellow ppt.

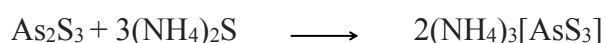

Yellow ammonium sulphide soluble complexes

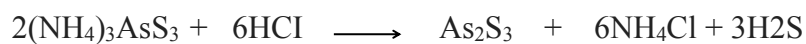

Yellow ppt.



Arsenic acid

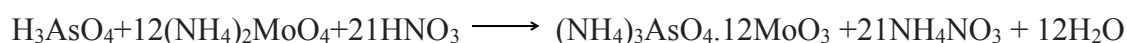

Yellow ppt. ammonium

arseno molybdate

Antimony (Sb³⁺)

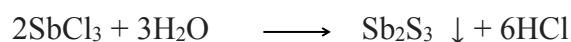

Orange

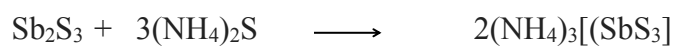

Soluble complex

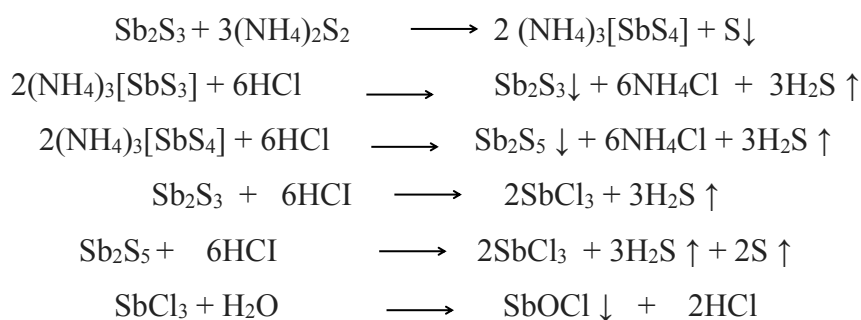

Milky (Turbidity)

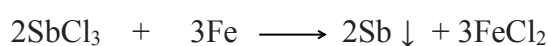

Black ppt

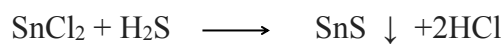
Tin (Sn^{2+} , Sn^{4+})**Test Ist**

Brown Black ppt.

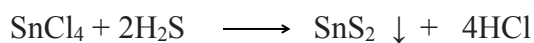

Yellow ppt.

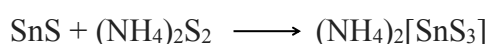
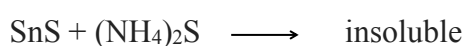

Soluble complex

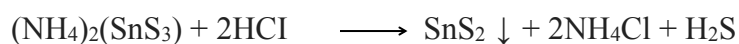
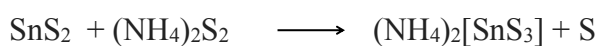
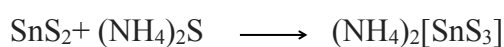

Yellow ppt.

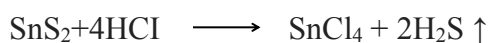
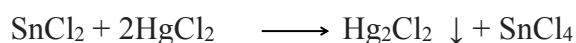
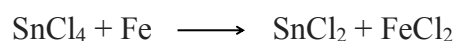
**2nd Test :**

White ppt.

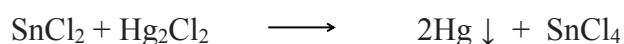

Grey ppt.

14.9 EXPERIMENT -1

14.9.1 Object : To analysis and identify the acidic and basic radicals in the given inorganic mixture

14.9.2 Apparatus Used : Inorganic mixture, beaker, Test tube, glass rod, funnel, filter paper, porcelin dish etc.dil. And conc. H_2SO_4 , H_2S gas.

14.9.3 Separation of inorganic mixture : In a beaker a minimum quantity of water with excess of Na_2CO_3 , double decomposition take place i.e. the radicals of the mixture join with the sodium and carbonate to anion (acid) and cation (basic) respectively. After heating it is mixed with water where sodium salts which contain anion are soluble and carbonates of metals remains as insoluble.

14.9.4 Preparation of sodium carbonate extract : Filtrate part or soluble anion of given mixture and add 3 part of pure Na_2CO_3 in a porcelin dish, add 15-20 ml. distilled water and heat with stirring about 5-10 minutes. Now filter, that's filtrate which obtained called sodium carbonate extract.

14.9.5 Observation

S. No.	Experiment	Observation	Results
1. Test for the acidic radicals			
(i)	Preliminary Test : Take small amount mixture in dry test tube and add dil. H_2SO	Evolution of colourless of colourless gas with brisk effervescence	Carbonate may be present
(ii)	Pass evolved gas in lime water	It turns milky	CO_3^{2-} may be present
(iii)	Confirmatory Test : If gas is passed for some more time	Turbid lime water again becomes clear solution	CO_3^{2-} conformed
(i)	Preliminary Test : Take mixture in dry test Evolution of colourless So may be	Evolved gas has	

	tube add dil. H ₂ SO ₄ and heat moderately.	smell of vinegar.	CH ₃ COO ⁻ may be present
(ii)	Confirmatory Test : In aqueous sol of mixture, neutral FeCl ₃ solution is added.	Blood red colour	CH ₃ COO ⁻ conformed
(iii)	Take some mixture on your palm add some solid oxalic acid and few drops of water to it and rub with fingers.	Smell like vinegar	CH ₃ COO ⁻ conformed
(i)	Preliminary Test : Heat mixture with conc. H ₂ SO ₄ in a dry test tube.	Pungent smelling red brown vapours are evolved.	Br ⁻ may be present
(ii)	Heat mixture with MnO ₂ and conc. H ₂ SO ₄ in a dry test tube.	Pungent smelling red brown vapours are more dense and vigorous.	Br ⁻ may be present.
(iii)	Confirmatory Test : Take approximately 2 ml. soda extract in a test tube, acidify it with dil. HNO ₃ and add AgNO ₃ solution.	Light yellow precipitate.	Br ⁻ may be present.
2. Test for the basic radicals			
A.	Take cold original solution in a test tube add to it dil. HCl White ppt + hot water then filter and filtrate into two part	White ppt is formed	First group may be present
(i)	Preliminary Test : Cool the filtrate part and add KI solution	Yellow ppt. of PbI ₂ appears	Pb ²⁺⁺ may be present
(ii)	Confirmatory Test : Add the CH ₃ COOH and K ₂ Cr ₂ O ₇ in the above filtrate part (in the ppt.)	Yellow ppt. of PbCrO ₄ is obtained	Pb ²⁺⁺ Confirmed
B.	Filtrate part of original solution, pass the	Black ppt. is	Second group

	H ₂ S gas Filter the black ppt. and filtrate part keep the test for second part of the II nd group.	formed	present
(i)	Preliminary Test : Take the filtrate part of the original solution and add the NH ₄ OH	Blue colour appears	Cu ²⁺ may be present
(ii)	Confirmatory Test : Now add the CH ₃ COOH in the original solution and then add K ₄ Fe(CN) ₆ solution	Chocolate brown ppt is formed	Cu ²⁺ Confirmed

14.9.6 Results : in the given inorganic mixture following acidic and basic radical are present ;

Acidic radicals : CO₃⁺⁺ (Carbonate), CH₃COO⁻ (acetate), Br⁻ (Bromide)

Basic radicals : Pb⁺⁺ (Lead), Cu²⁺ (Copper)

14.10 EXPERIMENT -2

14.10.1 Object : To analyse and identify the acidic and basic radicals in the given inorganic mixture

14.10.2 Apparatus Used : Inorganic mixture, beaker, Test tube, glass rod, funnel, filter paper, porculin dish etc.dil. And conc. H₂SO₄, H₂S gas.

14.10.3 Separation of inorganic mixture : In a beaker a minimum quantity of water with excess of Na₂CO₃, double decomposition take place i.e. the radicals of the mixture join with the sodium and carbonate to anion (acid) and cation (basic) respectively. After heating it is mixed with water where sodium salts which contain anion are soluble and carbonates of metals remains as insoluble.

14.10.4 Preparation of sodium carbonate extract : Filtrate part or soluble anion of given mixture and add 4 part of pure Na₂CO₃ in a porcelin dish, add 15-20 ml. distilled water and heat with stirring about 5-10 minutes. Now filter, that's filtrate which obtained called sodium carbonate extract.

14.10.5 Observation

S.No.	Experiment	Observation	Results
1. Test for the acidic radicals			
(i)	Preliminary Test : Take mixture in dry test tube Evolution of colourless So may be tube add dil. H ₂ SO ₄ warm gently.	Evolution of brown gas with pungent smell	NO ₂ ⁻ may be present
(ii)	Confirmatory Test : Bring a paper dipped in KI and starch solution in contact of liberated gas at the mouth of test tube.	Paper turns blue.	NO ₂ ⁻ conformed
(i)	Preliminary Test : Take mixture in dry test tube Evolution of colourless So may be tube add dil. H ₂ SO ₄ and heat moderately.	Evolution of colourless rotten egg smell.	S ²⁻ may be present
(ii)	Confirmatory Test : Bring a paper dipped in lead acetate solution in contact of evolved gas at the mouth of test tube.	Paper turns brown black.	S ²⁻ conformed
(iii)	Take 2 ml. Soda extract in a test tube, add to it 2-3 drops of sodium nitro prusside solution	Violet/purple colour	S ²⁻ conformed
(i)	Preliminary Test : Heat mixture with conc. H ₂ SO ₄ in a dry test tube.	Violet vapours are evolved	I ⁻ May be present
(ii)	Heat mixture in a test tube with solid MnO ₂ and conc. H ₂ SO ₄ Take 2 ml. soda extract in a test tube acidify it with dil HNO ₃ and add AgNO ₃ solution.	Dense violet vapours are evolved Dark yellow ppt.	I ⁻ May be present I ⁻ May be present

(iii)	Confirmatory test : Bring a paper dipped in starch in contact of vapours at the mouth of test tube.	Paper turns blue	I ⁻ Confirmed
(iv)	Add NH ₄ OH in ppt.	ppt. remains insoluble	I ⁻ confirmed.
	Layer Test		
(v)	Take 2 ml soda extract in a test tube, acidity with dil. HNO ₃ add 1 ml CCl ₄ and add Cl ₂ water/dil. HNO ₃ drop by drop shake well.	CCl ₄ layer turns violet	I ⁻ confirmed.
2. Test for the basic radicals			
A.	Heat a little mixture with 2-3 ml NaOH in a test tube. A characteristic smell of ammonia	Smell like ammonia	Zero group present
(i)	Preliminary Test : Glass rod dip in the dilute HCl and put that glass rod in the mouth of test tube	Enormous white fumes are produced	NH ₄ ⁺ may be present
(ii)	Add Nessler reagent in the aqueous solution of mixture	Brown colour or precipitate	NH ₄ ⁺ Confirmed
B.	Take the mixture in a beaker and add little amount of dil. HCl	White ppt. formed	First group present
(i)	Preliminary Test ; Shake the ppt. with NH ₄ OH and filter. And further add dil. HNO ₃	White ppt. appears	Ag ⁺ may be present
(ii)	Confirmatory test : Now add CH ₃ COOH and K ₂ CrO ₄ in the that residue	Red ppt. will form	Ag ⁺ confirmed
C	First group filtrate part add dil. HCl heat the solution and pass the H ₂ S gas	ppt. formed	Second group present
(i)	Preliminary Test ; It may have sulphate or nitrate of Bi, Cu and Cd. Add into this excess of NH ₃ and	White ppt. formed	Bi ³⁺ may be present

	filter.		
(ii)	<p>Confirmatory test : This white ppt. Dissolve in minimum amount of Conc and divide in 2 part</p> <p>1. First part dilute with water</p> <p>2. Add sodium stannite solution in the second part</p>	<p>White turbidity appears</p> <p>Black ppt formed</p>	<p>Bi³⁺ confirmed</p>

14.10.6 Results : in the given inorganic mixture following type of acidic and basic radicals are present

Acidic radicals: S²⁻, I⁻, NO₂⁻

Basic radicals : NH₄⁺, Ag⁺, Bi³⁺

14.11 SUMMARY

- This item provides the classification of anions (Acidic Radicals). A preliminary test is used to identify class I, class II, and class III anions.
- Instead of effervescing, the basic carbonates of Pb and Bi release CO₂ over time. Many sulphides, including those of Ag, Hg, As, Co, and Ni, do not decompose when heated with diluted HCl or diluted H₂SO₄. Oxalates of K⁺ and NH₄⁺ can dissolve in water.
- To make a solution of anions, soda extract preparation should be utilised. It is produced by boiling salt or a combination containing too much sodium carbonate solution.
- The Na₂CO₃ used to prepare soda extract should be clean and free of the contaminants chloride and sulphate, which are frequently present.
- This approach does not identify carbonate ion (CO₃²⁻), which already originates from sodium carbonate. As a result, it ought to be found in the solid salt or mixture.
- The purpose of this experiment is to identify the cations in a solution that is unknown. The unidentified solution's constituent chemicals were located through qualitative analysis. The unknown solution is subjected to qualitative examination using a number of reagents.

14.12 REFERENCES

1. Practical Chemistry by D. N. Bajpai, O P Pandey & S Giri, S Chand publication.

2. Advanced Practical Organic Chemistry by N K Vishnoi Vikas Publication.
3. Comprehensive Practical Organic Chemistry by V.K Ahluwalia and sunita Dhingra.
4. Text Book of Organic Practical Chemistry, A.I. Vogel.
5. Practical Physical Chemistry, J.B. Yadav.

14.13 TERMINAL QUESTIONS

1. What is the acidic radicals ?
2. What is the basic radicals?
3. How the sodium extract are prepared?
4. Acidic radicals are identify by how many type.
5. What is the confirmatory for the acetate
6. What is the group reagent for the zero group.
7. What is the group reagent for the second group basic radicals
8. Why Pb^{2+} present in the both first and second group?
9. What is the basic difference of the group reagent of second and fourth group? While both have H_2S as a group reagent.
10. What is the nessler reagent? Whai it do.
11. How the prepared neutral $FeCl_3$.
12. What is the basic difference between preliminary and confirmatory test.
13. Give the name acidic radical which identify by the specific reagent.
14. Give the name of the two basic radicals which present the second group.
15. What is the group reagent of the third group?

UNIT-15: ORGANIC EXERCISE**STEROCHEMISTRY AND FUNCTIONAL GROUP ANALYSIS OF ORGANIC MOLECULES**

CONTENTS:

15.1 Introduction

15.2 Objectives

15.3 3D-Structural representation of Organic molecule

15.4 Fischer Projections

15.4.1 How to draw Fischer projections

15.4.2 Determination of stereochemistry using Fischer projections

15.5 Quantitative and qualitative analysis

15.6 Identify the functional group present in the organic compounds

15.7 Summary

15.8 Bibliography/References

15.9 Solved experimental problem

15.1 INTRODUCTION

Organic compounds are compounds in which carbon and hydrogen are covalently bonded to each other. An organic compound has a single chemical formula; however, the structural representations of compounds may vary. The structural formula of an organic compound is a schematic representation of the molecule, showing the arrangement of the atoms in space and represented as Entire structure, condensed structure and bond-line structural formula.

15.2 OBJECTIVES

After completing this unit learners will be able to

- Read and draw molecular, structural formula of organic compounds.
 - Know and draw the 3D-representation of molecule using Fischer Projections.
 - Determine the stereochemistry of molecule and assign the R,S notation/configuration to the chiral centre/carbon using Fischer Projections.
 - Know the difference between quantitative and qualitative analysis.
 - Differentiate between alkane, alkene and alkyne.
 - Identify the functional group present in the organic molecules.
-

15.3 3D STRUCTURAL REPRESENTATION OF ORGANIC MOLECULE

Organic compounds are the most utilized compounds in chemistry and even in our daily lives. Each organic compound has one chemical formula, but you can use different formulas to represent it on paper depending on how easy it is for us to work with it and how complicated the structure is? The structures of organic compounds can be represented in different ways such as complete structural formula, condensed structural formula, bond line structure formula, polygon formula and 3D representation.

In organic molecules, a line drawing is typically used to represent the molecule in two dimensions. This line drawing is based on standard chemical notation, which indicates the connectivity of the atoms in the molecule. Similarly, in three dimensions, a ball and stick model is used to represent the molecules, which is based on the same chemical notation. A three-dimensional (3-D) structure of organic molecules can be represented on paper by using certain representation viz. Flying-wedge (wedge-dash) projection, Fischer projection, Newman projection and Sawhorse projection.

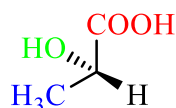

Flying-wedge projection

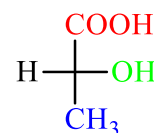

Fischer projection

Fig 15.1: 3D Representation of lactic acid

15.4 FISCHER PROJECTIONS

Fischer projection is a representation of 3D molecule structure of compound in 2D projection as flat structure with stereocenter or chiral centers proposed by Hermann Emil Fischer in 1891. Fischer projection simplifies the drawing of the structures of compounds containing multiple chirality centers with the main idea of not having to draw the wedge and dash lines for every single chiral center. There are following Fischer projection rule:

- The Fischer projection formula is the convention used to represent a stereo formula in 2D space without eliminating the stereochemical information and absolute configurations at chiral centres.

- The horizontal lines are indicated by attachments pointing outward from the paper towards the viewer. It is assumed that the attachments are on a wedge pointing 90 degrees outward from the observer.
- The vertical lines represent attachments pointing out the back of the paper away from the observer. They are implied to be on a dash, 180 degrees away from the observer.
- The intersections represent a central carbon, which may or may not be a stereocenter which takes on distinct conformations.
- Enantiomers will be arranged opposite to each other at each chirality center or stereocenter, so that all groups that were on the left-hand side of the chirality center will be on the right-hand side, and groups that were originally on the right-handed side will be on the left-handed side.

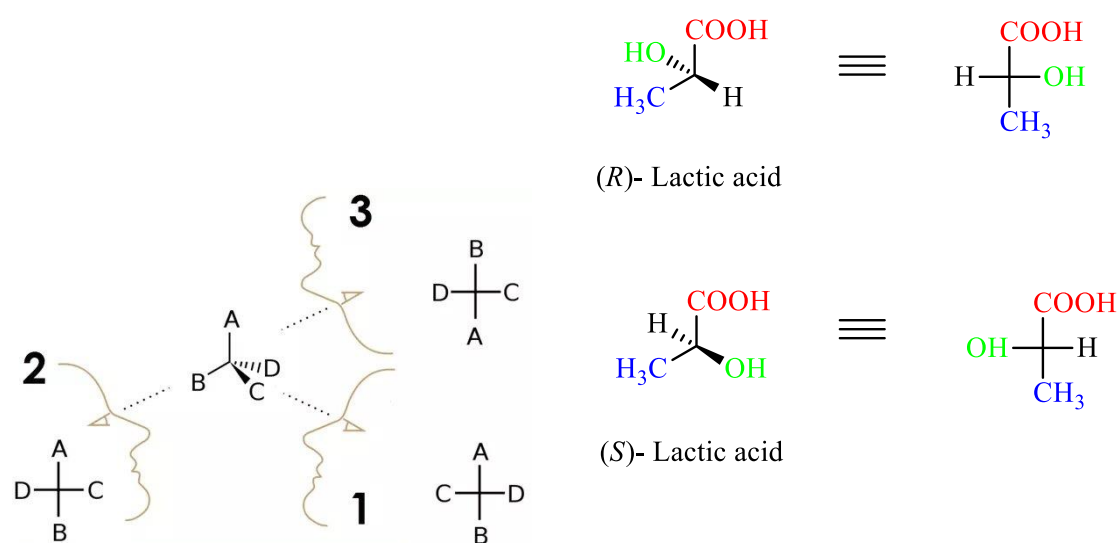

Fig. 15.2: Fischer projection of lactic acid

15.4.1 How to draw Fischer projections

3D structure of a molecule into 2D representation according to the Fischer projection rule can be drawn as per following steps:

- Construct the molecule so that the chiral center is on the plane of the screen. Have those two bonds coming out of the plane of the paper rest on a horizontal plane, and then place the two remaining bonds (those going into the plane of the paper) on a vertical plane.

- ii) All wedge and dash bonds should be pulled to the same plane on the screen, and the symbol for the chiral carbon should be omitted.
- iii) For example if you look at the molecule from the top, you will see the following representation where the **two groups** on the side are pointing towards and the **ones on the top and on the bottom** are pointing away from you. We will show the ones on the sides with wedge lines and the others with dashed lines.

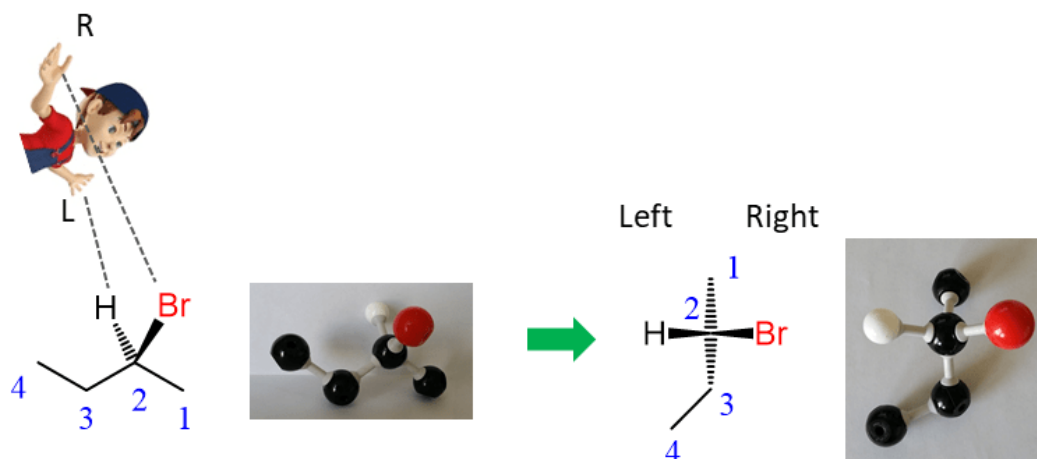

(Source: <https://www.chemistrysteps.com/fischer-projection/>)

- iv) Draw the molecule structure show all the bonds with plane solid lines, keeping in mind that the horizontal groups are pointing towards you and the ones on the vertical line are pointing away from you and being able to convey absolute configuration of the chirality centers (R, S).

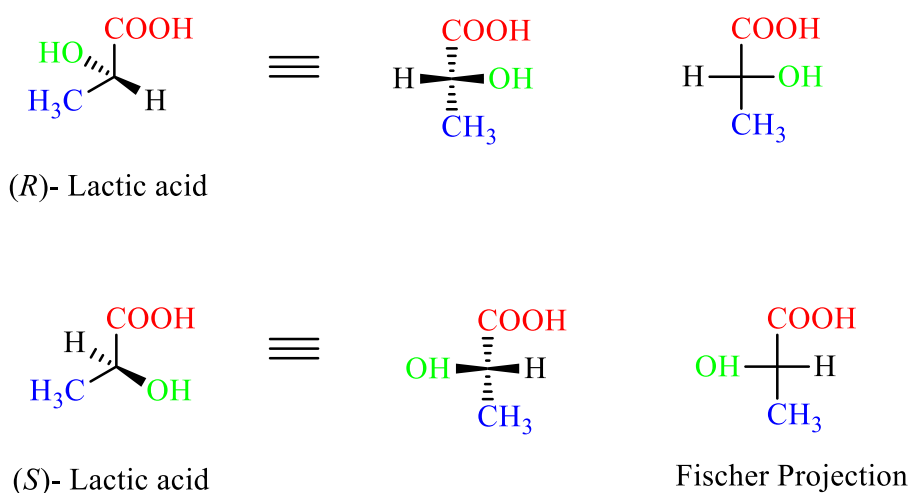

Fig. 15.3: Drawing of lactic acid structure according to Fischer projection

15.4.2 Determination of stereochemistry using Fischer projections

To determine the stereochemistry/absolute configuration(R,S) of chirality centers in a Fischer projection, you need to follow the these steps:

- In the molecule, assign the priorities of the groups on the chiral center based on the atomic numbers (Cahn-Ingold-Prelog rules).
- Perform the two allowed manipulations/exchange of group (Fischer projections can be rotate by 180° only or Rotate three group and hold steady one group) of the Fischer projection to place the lowest priority group at the top (or bottom).
- Draw the arrow going from priority 1-2-3.
- If the priority of the groups 1-2-3 is clockwise then assign the center as **R**, if 1-2-3 is counterclockwise then assign the center as **S**.

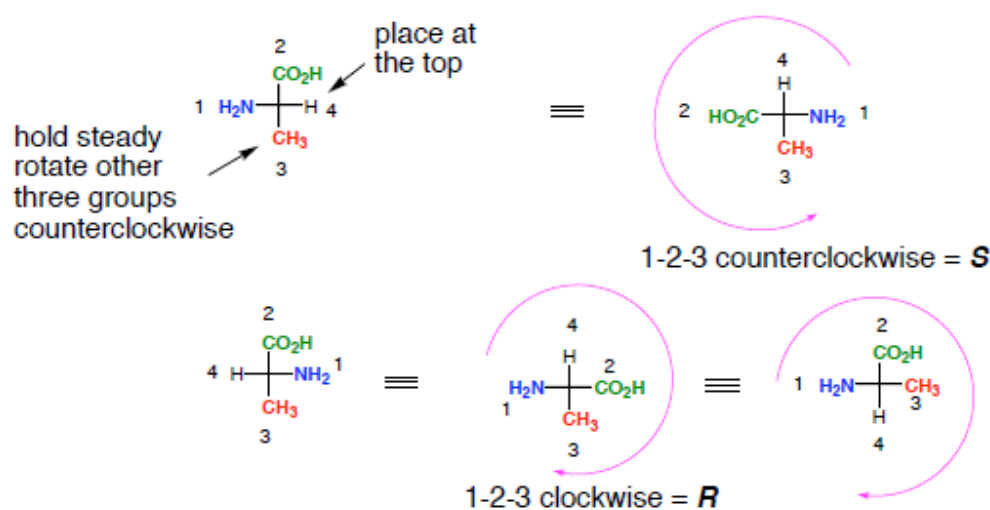

Fig. 15.4: Stereochemistry/absolute configuration (R,S) of chirality centers in a Fischer projection

- When you not manipulate in the Fischer projection then if lowest priority group not at the top or bottom the configuration at chiral centre must be switched from **R** to **S** or **S** to **R** as the rules of Cahn-Ingold-Prelog system is that the lowest priority must point away from the viewer. For example in the given molecule chiral centre priority sequence is clockwise so that assigne configuration **R** but the lowest priority groups not on the top/bottom so that chiral centre configuration **R** switched to **S**. Hence the chiral centre has absolute configuration **S**.

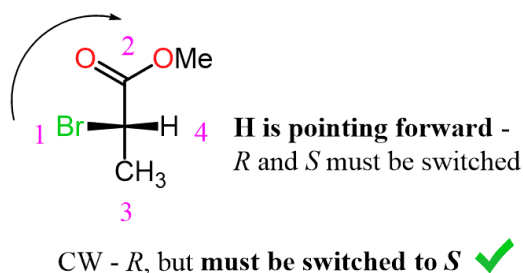

Fig. 15.5: Reversal of Stereochemistry/absolute configuration at chiral centers

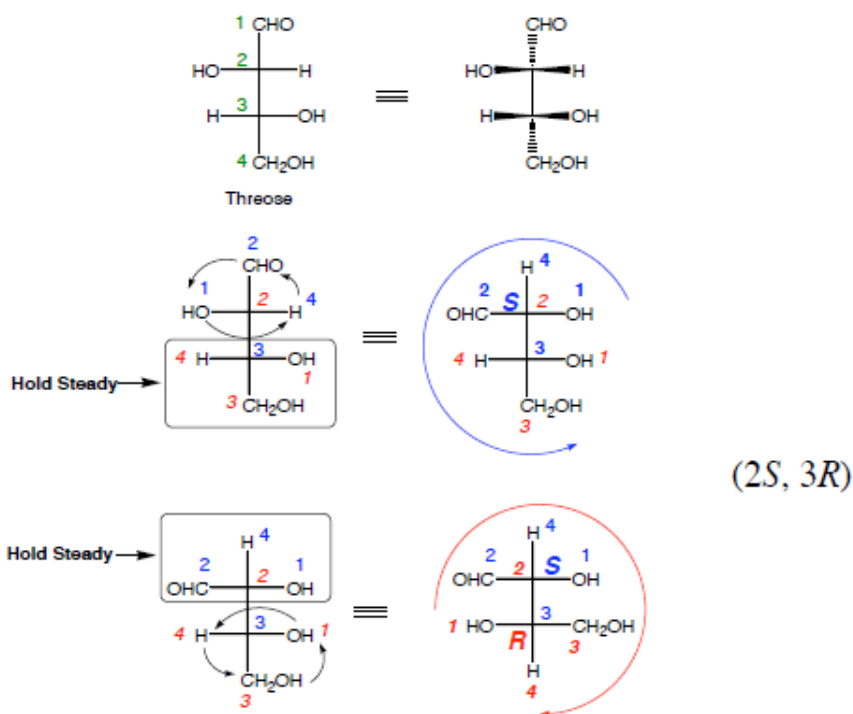

Fig. 15.6: Stereochemistry/absolute configuration (R,S) with more than one chiral centers in a Fischer projection

15.5 QUANTITATIVE AND QUALITATIVE ANALYSIS

Quantitative and qualitative analysis basically used in the chemistry practical or analytical analysis.

A. Quantitative analysis

Quantitative analysis is the process of determining the quantity of a particular component present in a sample. The quantity can be expressed as mass, concentration or the relative abundance of a sample's component or all components. The following are some sample quantitative analysis.

- The primary tool for quantitative analysis is the analytical balance or scale, which is used to measure mass precisely.
- The solution is 0.1M NaOH.
- The yield of the chemical reaction is 1.2341 g.

The quantification of a sample can be divided into two broad categories: physical methods and chemical methods. A physical method measures a physical property, for example, light absorption, density and magnetic susceptibility etc. Fourier Transform Infrared Spectroscopy (FTIR), Atomic Emission Spectroscopy (AES), Energy Dispersive X-ray Spectroscopy (EDS), Trace element analysis, X-ray fluorescence spectroscopy etc. are the commonly used physical methods for the quantitative analysis now days. On the other hand Chemical methods involve chemical reactions, such as oxidation, precipitation, or neutralization to form a new chemical compound. Titration (volumetric analysis), Gravimetric analysis, various wet chemistry tests, Combustion analysis are used in chemical method.

B. Qualitative analysis

Qualitative analysis deals with the identification of elements or functional group present in a sample. The results of this analysis do not provide any information about the amount/quantity of the chemical component. The sample's colour, odour, melting point, boiling point, reactivity, precipitation, and other characteristics parameters are often taken into account during the analysis. For example, a reaction may be observed to produce a gas that is out from the solution as bubble, or a reaction may result in a change in color.

Qualitative analysis can be divided into two main categories: organic and inorganic. In organic qualitative analysis, the functional groups (-OH, -COOH, -NO₂ etc.) and the chemical bonds of the sample are determined while Inorganic qualitative analysis is mainly concerned with identification and separation of ions in the sample (e.g. cations, anions).

15.6 IDENTIFY THE FUNCTIONAL GROUP PRESENT IN THE ORGANIC COMPOUNDS

Functional groups are a class of atoms or bonds within a substance that play a role in the chemical reactions of the substance in organic chemistry. For example, two molecules of different sizes that share the same functional group will participate in similar or identical chemical reactions. Organic compounds other than hydrocarbons may be divided into two

components: a reactive component, known as the functional group, and a carbon skeleton, known as the alkyl group. On the basis of the elements present in the organic compound, it can be classified into the following groups:

1. Organic compound containing carbon(C) and hydrogen (H)
2. Organic compound containing carbon(C), hydrogen (H) and halogen (F, Cl, Br, I)
3. Organic compound containing carbon(C), hydrogen (H) and oxygen (O)
4. Organic compound containing carbon(C), hydrogen (H), oxygen (O) and halogen
5. Organic compound containing carbon(C), hydrogen (H) and nitrogen (N)
6. Organic compound containing carbon(C), hydrogen (H), oxygen (O) and nitrogen (N)
7. Other derivatives of organic compounds
8. Some examples:

S. No.	Class of Compounds	Functional Group
1.	Hydrocarbon (Alkene)	>C=C<
2.	Hydrocarbon (Alkyne)	$\text{—C}\equiv\text{C—}$
3.	Alkyl halides	RX (X= F,Cl,Br,I)
4.	Alcohol	-OH (Hydroxyl)
5.	Carboxylic acid	-COOH (Carboxyl)
6.	Acyl halide	$\text{-COOX (X= F,Cl,Br,I)}$
7.	Aldehyde	-CHO
8.	Ketone	=CO
9.	Amine	-NH_2
10.	Amide	=CONH_2

15.6.1 Hydrocarbon functional group

Hydrocarbons are compounds that are only made up of carbon and hydrogen. They are divided into two categories: saturated and unsaturated.

- Saturated hydrocarbons only have single bonds between the carbon atoms C—C and the hydrogen atoms C—H. That is because all four valencies of the carbon atoms are satisfied with single bonds. For example Methane, Ethane, Propane etc.
- Unsaturated hydrocarbons are the compounds that contain multiple bonds (double and triple bond) between carbon-carbon. For example Ethene, Propene, 1-Butyne etc.

15.6.2 Identify the Hydrocarbon functional group (Unsaturation test)

Organic compounds containing $>C=C<$ and / or $-C\equiv C-$ bonds are called unsaturated compounds. There are two tests (Bromine test and Bayer's test) for detecting unsaturation in organic compound.

1. Bromine Test:

In this test, the orange-red colour of bromine solution disappears when it is added to the unsaturated hydrocarbon to form colourless addition products.

A. Theory:

These compounds undergo addition reaction with bromine water or the solution of bromine in carbon tetrachloride, chloroform or glacial acetic acid. Addition of bromine to an alkene results in the formation of vicinal dibromide. The reddish orange colour of the solution of bromine in carbon tetrachloride disappears on reaction with an alkene. The reaction is as follows:

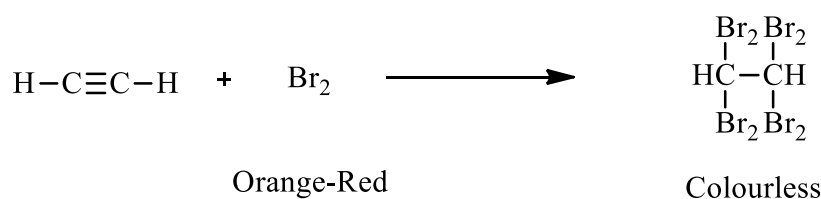
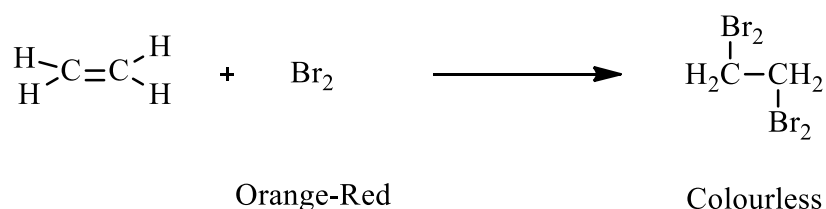

B. Procedure

◆ When the compound is soluble in water:

Dissolve a part of the given compound (solid or liquid) in about 2 ml of distilled water in a test-tube and add a drop of bromine water and shake. Disappearance/Decolourization of orange-red colour of bromine indicate unsaturation. Continue the addition of bromine water drop wise with constant shaking and bring a rod dipped in NH_4OH near the mouth of the test-tube. Absence of white fumes confirms unsaturation.

◆ **When the compound is insoluble in water:**

Dissolve a small amount of the given compound in 1 ml of carbon tetrachloride (CCl₄) in a test tube and add 2% solution of bromine in CCl₄ or bromine water drop wise drop and Shake the mixture. Disappearance/ Decolourization of orange-red colour indicate unsaturation. Continue the drop wise addition of Br₂ water with constant shaking and bring a rod dipped in NH₄OH near the mouth of the test-tube. Absence of white fumes confirms unsaturation.

2. Alkaline KMnO₄ Test (Bayer's test):

In this test, the pink colour of KMnO₄ disappears, when an alkaline KMnO₄ is added to an unsaturated hydrocarbon. The disappearance of pink colour may take place with or without the formation of brown precipitate of MnO₂.

A. Theory:

Alkenes decolourise the neutral/alkaline KMnO₄ solution and vicinal glycols are formed (Bayer's test). Reaction takes place as follows:

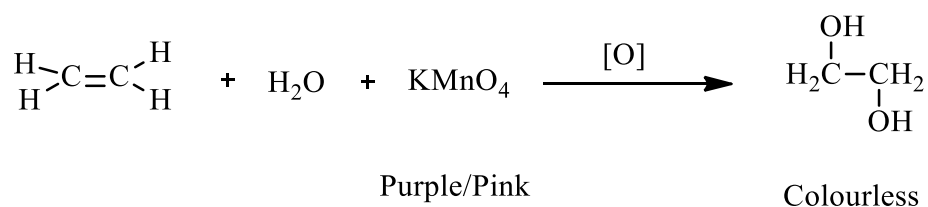

B. Procedure:

Dissolve a little amount of the given organic compound in about 2 ml of water or acetone in a test-tube. Add 1-2 drops of (1%) alkaline solution of potassium permanganate (KMnO₄) and shake the mixture. Decolourization/ Disappearance of pink colour of KMnO₄ indicate unsaturation.

15.6.3 Preparation of reagents

- 1. Bromine water:** Add 2 ml of liquid bromine in 100 ml of distilled water and shake. Decant off the clear liquid.
- 2. Bromine in carbon tetrachloride (CCl₄):** Shake 2 ml of liquid bromine in 100 ml of CCl₄ and stopper the bottle.
- 3. (1%) Alkaline potassium permanganate (KMnO₄):** Dissolve 1g of KMnO₄ (solid) in 100 ml of distilled water. Now add 10g of anhydrous Na₂CO₃. Shake to dissolve and stopper the bottle.

15.7 SUMMARY

The summary of this unit summarised as:

- Fischer projection is a representation of 3D molecule structure of compound in 2D projection as flat structure with stereocenter or chiral centers proposed by Hermann Emil Fischer in 1891. Fischer projection simplifies the drawing of the structures of compounds containing multiple chirality centers with the main idea of not having to draw the wedge and dash lines for every single chiral center.
- The stereochemistry/absolute configuration(R,S) of chirality centers in a Fischer projection, determine by Cahn-Ingold-Prelog rules.
- Quantitative and qualitative analysis basically used in the chemistry practical or analytical analysis. Quantitative analysis is the process of determining the quantity of a particular component present in a sample while Qualitative analysis deals with the identification of elements or functional group present in a sample.
- Hydrocarbons are compounds that are only made up of carbon and hydrogen. They are divided into two categories: saturated and unsaturated.
- Organic compounds containing $>C=C<$ and / or $-C\equiv C-$ bonds are called unsaturated compounds. There are two tests (Bromine test and Bayer's test) for detecting unsaturation in organic compound.

15.8 BIBLIOGRAPHY/REFERENCES

1. P S Kalsi, Stereochemistry: Conformation and Mechanis, New Age International (P) Ltd Publishers.
2. Sudha Goyal, Chemistry Practical-I, Krishna Publication Media (P) Ltd. Meerut, 2017.
3. O. P. Pandey, D. N. Bajpai, and S. Giri, Practical Chemistry, S Chand & Co Ltd

15.9 SOLVED EXPERIMENTAL PROBLEM

SOLVED EXPERIMENTAL PROBLEM: 1**1. Aim/Object**

To draw the Fischer projection representation and determine the stereochemistry/absolute configuration at chiral centre in an organic compound.

2. Fischer projection

Fischer projection is a representation of 3D molecule structure of compound in 2D projection as flat structure with stereocenter or chiral centers proposed by Hermann Emil Fischer in 1891. Fischer projection simplifies the drawing of the structures of compounds containing multiple chirality centers with the main idea of not having to draw the wedge and dash lines for every single chiral center. There are following Fischer projection rule:

- The Fischer projection formula is the convention used to represent a stereo formula in 2D space without eliminating the stereochemical information and absolute configurations at chiral centres.
- The horizontal lines are indicated by attachments pointing outward from the paper towards the viewer. It is assumed that the attachments are on a wedge pointing 90 degrees outward from the observer.
- The vertical lines represent attachments pointing out the back of the paper away from the observer. They are implied to be on a dash, 180 degrees away from the observer.
- The intersections represent a central carbon, which may or may not be a stereocenter which takes on distinct conformations.

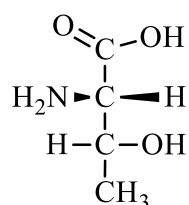
**3. Stereochemistry determination**

In the Fischer projection representation of the given compound two chiral centre present at the cross point of horizontal and vertical line. In the molecule at top chiral centre priority sequence of attached group according to Cahn-Ingold-Prelog is clock wise so that assigne

configuration *R* but the lowest priority groups not on the top/bottom so that chiral centre configuration *R* switched to *S*. While at bottom chiral centre priority sequence of attached group according to Cahn-Ingold-Prelog is anti clock wise so that assigne configuration *S* but the but the lowest priority groups not on the top/bottom so that chiral centre configuration *S* switched to *R*.

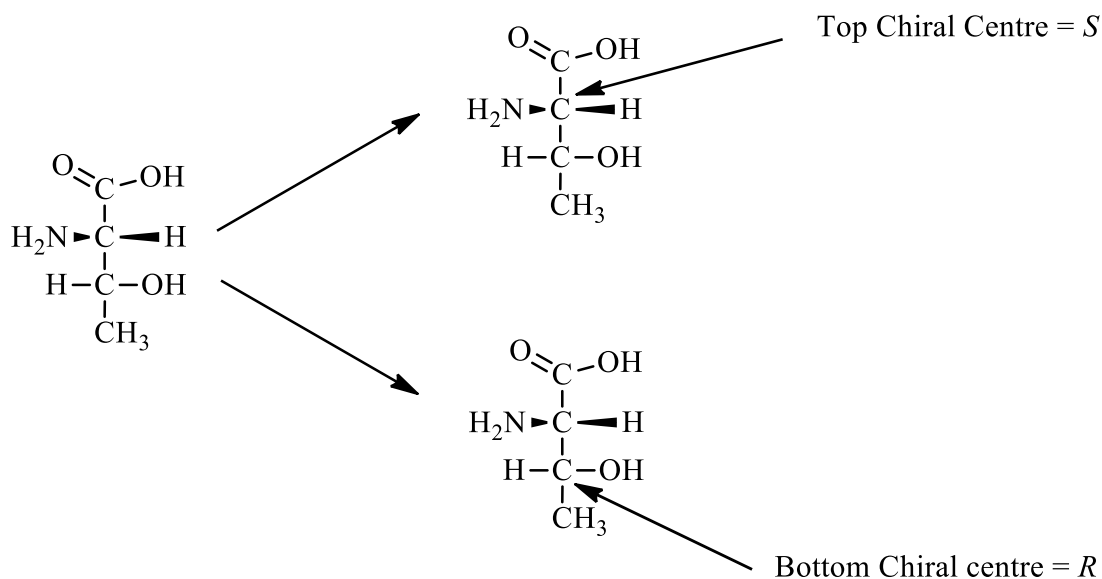

4. Result: In the given organic compound the Fischer projection representation show two chiral centre in which top chiral centre have absolute configuration is *S* and bottom chiral centre have absolute configuration *R*.

SOLVED EXPERIMENTAL PROBLEM: 2**1. Aim/Object**

To identify the functional groups present in an organic compound.

2. Material /apparatus required

- Test tubes
- Test tube holder
- Given organic compound
- Carbon tetra chloride (CCl₄)
- Potassium permanganate (KMnO₄) solution
- Bromine water
- Bromine
- Sodium carbonate (Na₂CO₃)
- Ammonium hydroxide (NH₄OH)

3. Theory of alkaline KMnO₄ Test (Bayer's test):

Organic compounds containing > C = C < and / or — C ≡ C — bonds are called unsaturated compounds. There are two tests (Bromine test and Bayer's test) for detecting unsaturation in organic compound.

Alkenes decolourise the neutral/alkaline KMnO₄ solution and vicinal glycols are formed (Bayer's test). Reaction takes place as follows:

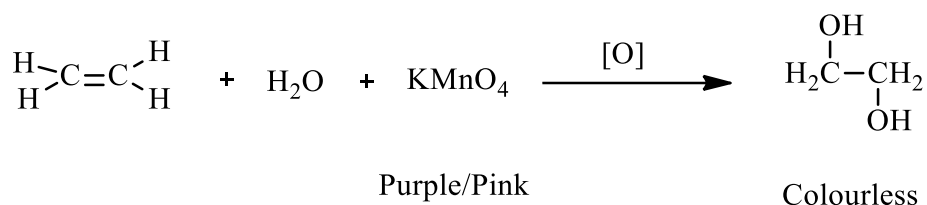
**4. Preparation of reagents**

(1%) Alkaline potassium permanganate (KMnO₄): Dissolve 1 g of KMnO₄ (solid) in 100 ml of distilled water. Now add 10g of anhydrous Na₂CO₃. Shake to dissolve and stopper the bottle.

5. Experiment:

S. No.	Experiment	Observation	Inferences
1.	Dissolve a little amount of the given organic compound in about 2 ml of water or acetone in a test-tube. Add 1-2 drops of (1%) alkaline solution of potassium permanganate (KMnO_4) and shake the mixture	Decolourization/ Disappearance of pink colour of KMnO_4	Unsaturation present

6. Result: In the given organic compound unsaturation (multiple bonds) present.

7. Precautions:

- The tests should be performed at room temperature.
- Handle bromine solution carefully. Do not inhale the vapours and also avoid its contact with the skin.

UNIT 16: PHYSICAL EXERCISE

DETERMINATION OF RELATIVE SURFACE TENSION

CONTENTS:

- 16.1 Introduction
- 16.2 Objectives
- 16.3 Measurement of surface tension
- 16.4 Experimental problem
- 16.5 Summary
- 16.6 Bibliography/References

16.1 INTRODUCTION

Surface tension refers to the force exerted on the individual surface of a fluid in order to reduce the surface area of the fluid to its minimum size. Thus “Surface tension is the tension of the surface film of a liquid caused by the attraction of the particles in the surface layer by the bulk of the liquid, which tends to minimise surface area”.

The surface tension of liquid molecules is due to the interaction of the cohesion force between the molecules of the liquid. Cohesion force is the attraction between two solid and liquid particles, and Cohesion force required to hold the solid and liquid particles together (Fig.16.1).

Mathematically, the surface tension is defined as the force (F) acting on the surface and the length (l) of the surface. Surface tension (denoted with the Greek variable γ) and measured in SI units of N/m (newton per meter), although the more common unit is the cgs unit dyn/cm (dyne per centimeter). Each liquid is characterized by its own surface tension, which decreases with an increasing temperature.

Examples of Surface Tension: Various examples which are explained with the help of Surface tension are,

1. **Walking on Water:** Various insects can easily walk on the surface of the water because the force of their weight is not enough to penetrate the surface of the water.

2. **Floating Needle:** A needle made of steel can easily be made to float on the surface of the water even though it is many times denser than water because of the surface tension of the water.
3. **Spherical Shape of Water Droplets:** Small droplets of fluid are spherical due to surface tension. The molecules of water tend to stick together due to intramolecular force, and the energy of molecules that are located on the surface of droplets contains higher energy and tries to push the other molecule to the centre of the droplet. Due to this the drop makes the shape that contains the least surface area and the spherical shape is best for the least surface area, that's why the droplets of water and raindrops are spherical.

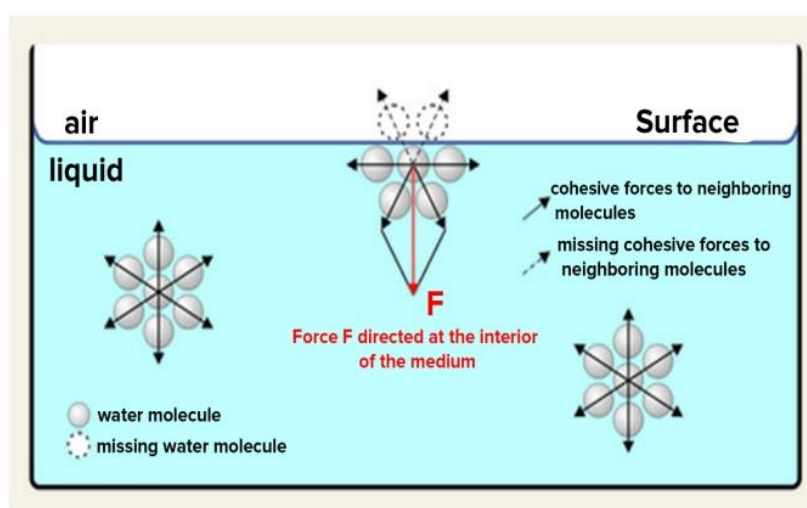
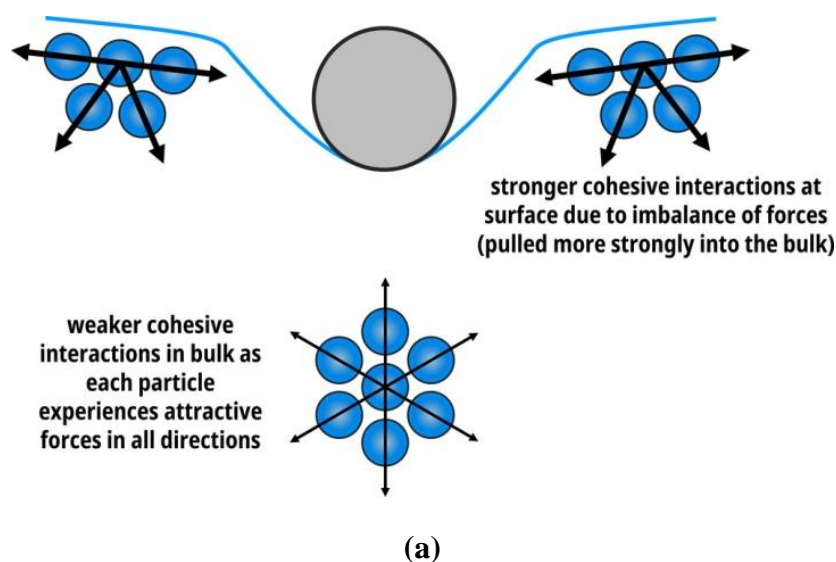

Fig. 16.1: Surface tension is caused by the net inward pull on the surface molecules

16.2 OBJECTIVES

After completing this unit learners will be able to.

- Know about the surface tension.
- Know the application of surface tension.
- Known the use of stalagmometer and relative density (R.D.) bottle.
- Determine the relative surface tension of given liquid.

16.3 MEASUREMENT OF SURFACE TENSION

There are various methods used to measure/determine the surface tension of any liquid such as Capillary Rise Method, Bubble Pressure Method, Spinning Drop Method, Du Noüy–Padday Method, Du Noüy Ring Method, Stalagmometric Method and Sessile Drop Method.

16.3.1 Surface tension by using the stalagmometer

Stalagmometer is a glass tube, widened in the middle part (Fig. 16.2). Its volume is calibrated by the scale shown on the tube, or by the top and bottom lines. The bottom part of stalagmometer is modified such that the liquid flowing through its smaller diameter forms drops. The drop of a mass m gets released when its weight $G = mg$ is equal or greater than the surface force at the end of tube:

$$mg = 2\pi\gamma r$$

Equation suggests that the surface tension (γ) can be calculated from the known liquid mass (m) and the radius of stalagmometer tube (r). However, it was shown experimentally, that only about 2/3 of the drop volume gets released. In addition, this portion is not constant for all the drops. In the fig.16.2 stalagmometer with a calibrated scale, the ratio of the mass and surface tension is constant for all the liquids:

$$m_1/\gamma_1 = m_2/\gamma_2$$

or

$$\gamma_1/\gamma_2 = m_1/m_2$$

Where m_1 and m_2 are the masses of drop 1 and 2 respectively, and the γ_1 and γ_2 surface tensions corresponding to these liquids. If the liquid with known surface tension is used for one of them, the surface tension of the other liquid can be calculated from the equation:

$$\gamma_1 = (m_1/m_2) \cdot \gamma_2$$

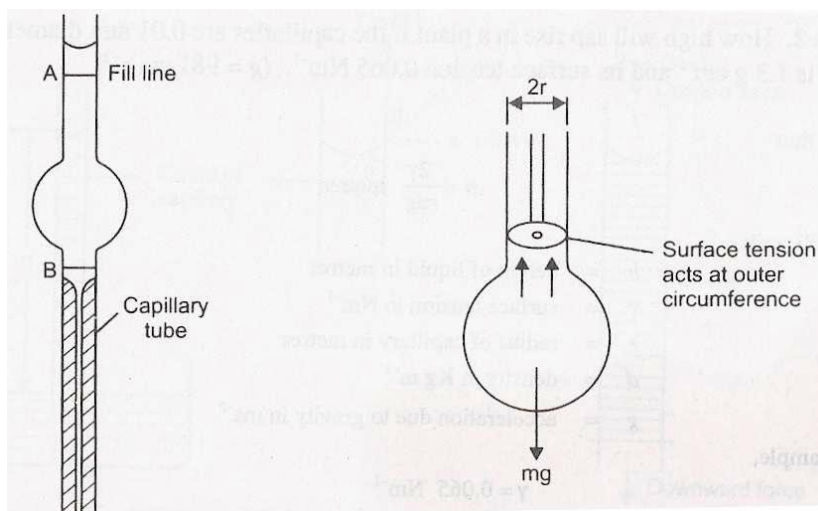

Fig 16.2: Stalagmometer

16.4 EXPERIMENTAL PROBLEM

1. Aim/Object:

Determine the relative surface tension of a given liquid at room temp using stalgmeter by drop number method.

2. Requirements:

Stalgmeter, specific gravity bottle/R.D. bottle, a small rubber tube with a screw pinch cork, distilled water, experimental liquid.

3. Theory:

In the drop number method, the number of drops formed by equal volumes of two liquid is counted. The liquid whose surface tension is to be determined is sucked from the rubber tubing above the mark A and number of drops are counted when the liquid level moves from A to B (Stalgmeter). Suppose the volume of the liquid from A to B is V and number of drops formed in this volume V are n then volume of one drop will be V/n_1 and mass of one drop $m_1 = \frac{V}{n_1} \times d_1$ where d_1 is density of the liquid.

The same procedure is adopted for water. In case of water if in the volume V i.e. when water level moves from A to B if n_2 number of drops are formed and density of water if d_2 then mass of one drop of water will be $m_2 = \frac{V}{n_2} d_2$

$$\gamma_1/\gamma_2 = m_1/m_2$$

By putting the value of m_1 and m_2 in the above equation, then their surface tensions are related as

$$\gamma_1/\gamma_2 = n_2d_1/n_1d_2$$

The density of the liquid and water are measured by density bottle and γ_2 surface tension of water is taken from standard (Known). Then relative surface tension of a liquid can be calculated by using this formula.

$$\gamma_1 = \frac{n_2d_1}{n_1d_2} \gamma_2$$

4. Procedure:

- Clean the stalgmometer with chromic acid solution, wash with water and dry it.
- Attach a small piece of rubber tube having a screw pinch cock at the upper end of the stalgmometer.
- Immerse the lower end of the stalgmometer in distilled water and suck the water 1-2cm above mark A. adjust the pinch cork so that 10-15 drops fall per minute.
- Clamp the stalgmometer allow the water drops to fall and start counting the number of drops when the meniscus crosses the upper mark A and stop counting when the meniscus passes mark B.
- Repeat the exercise to take three to four readings.
- Rinse the stalgmometer with alcohol and dry it.
- Suck the given liquid in the stalgmometer and count the drops as in case of water.
- Take a clean dry weighing bottle weighs it with water as well as with liquid.
- Measuring density of a liquid and water the density bottle (R.D. bottle) is washed with chromic acid solution and then with distilled water and finally with alcohol. It is then dried. The density bottle is then weighed. It is then filled with distilled water and again weighed. It is then emptied of water, washed with alcohol and dried. The density bottle is then filled with experimental liquid and weighed again.
- Note the temperature where experiment was carried out.

5. Observations:

Room temperature = °C

Mass/Weight of empty R.D. bottle (w_1) = gm

Mass/Weight of R.D. bottle and water (w_2) = gm

Mass/Weight of R.D. bottle and liquid (w_3) = gm

Table for number of drops with liquid and water

S. No.	Number of drops			
	Water	Mean Value (n_1)	Liquid	Mean Value (n_2)
1.	-----	-----	-----	-----
2.	-----		-----	
3.	-----		-----	

6. Calculations:**A. Determination of density:**

Mass/Weight of water (w_2-w_1) =gm

Mass/Weight of Liquid (w_3-w_1) =gm

$$\frac{\text{Density of liquid}(d_2)}{\text{density of water } (d_1)} = \frac{\text{Weight of liquid}}{\text{Weight of water}}$$

$$\frac{(d_2)}{(d_1)} = \frac{(w_3-w_1)}{(w-w_1)}$$

B. Determination of relative surface tension:

Then relative surface tension of a liquid can be calculated by using this formula.

$$\gamma_1 = \frac{n_2 d_1}{n_1 d_2} \gamma_2$$

7. Result: The relative surface tension of the given liquid at°C is dynes/cm

8. Precautions:

- The stalagmometer should be washed properly with chromic acid water and finally with alcohol.
- The stalagmometer should be held vertically.
- The tip of the stalagmometer should not come in contact with hands or working table.
- The drops should be allowed to fall off from stalagmometer tip under their own weight and should not be pushed away by kinetic flow.
- The rate of flow of liquid be 12-18 drops per minute.

16.5 SUMMARY

The present unit may be summarized as:

- Surface tension is the tension of the surface film of a liquid caused by the attraction of the particles in the surface layer by the bulk of the liquid, which tends to minimise surface area". Surface tension (denoted with the Greek variable gamma) and measured in SI units of N/m (newton per meter), although the more common unit is the cgs unit dyn/cm (dyne per centimeter).
- Due to the surface tension shape of water droplet is spherical and insect walk on the water surface.
- Surface tension can be determined by drop count method using the stalagmometer apparatus.
- Density of liquid and water determine/measurement by using relative density bottle (R.D. bottle).
- Then relative surface tension of a liquid can be calculated by using this formula.

$$\bullet \quad \gamma_1 = \frac{n_2 d_1}{n_1 d_2} \gamma_2$$

16.6 BIBLIOGRAPHY/REFERENCES

1. Sudha Goyal, Chemistry Practical-II, Krishna Publication Media (P) Ltd. Meerut, 2017.
2. O. P. Pandey, D. N. Bajpai, and S. Giri, Practical Chemistry, S Chand & Co Ltd