

BLOCK – II OPERATIONAL AMPLIFIERS

UNIT 9: Operational Amplifier Configuration



Dr. Meenakshi Rana

Academic Consultant

Department of Physics

Uttarakhand Open University, Haldwani

Content

- 1. Introduction.**
- 2. Circuit symbol and terminals.**
- 3. Block diagram**
- 4. OP-AMP input modes**
 - Single ended mode**
 - Double ended mode**
 - Common mode**
- 5. Comparison of ideal and practical OP-AMP**
- 6. Configuration of op-amp**
 - Open loop configuration**
 - Closed loop configuration**
- 7. Advantages of negative feedback**
- 8. Virtual short.**
- 9. Virtual Ground**
- 10. Useful links.**

Objective

After studying this unit one should be able to;

1. Define circuit symbol and terminals of OP-AMP.
2. Explain different modes of OP-AMP.
3. Can Compare ideal and practical OP-AMP.
5. Configuration of op-amp
6. Advantages of negative feedback
7. Define virtual short and virtual round

OP-AMP

Introduction

- OP-AMP is basically a multistage amplifier which uses a number of amplifier stages interconnected to each other.
- The integrated op amp offers all the advantage of monolithic integrated circuit such as small size ,high reliability ,reduced cost, less power consumption.
- OP-AMP amplifies the difference between two signal and diminish common signal.

Symbol and terminals

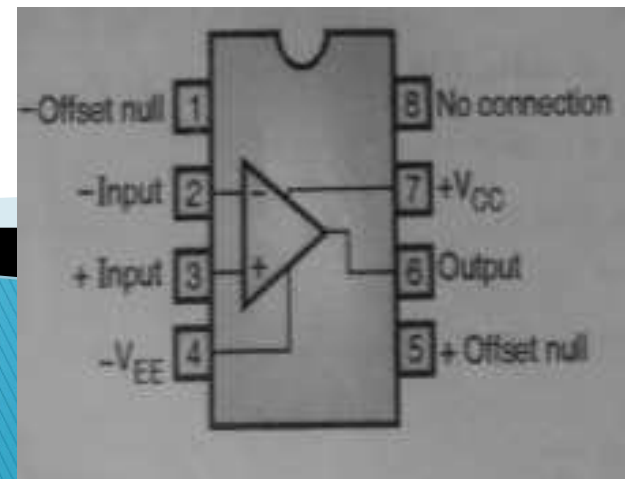
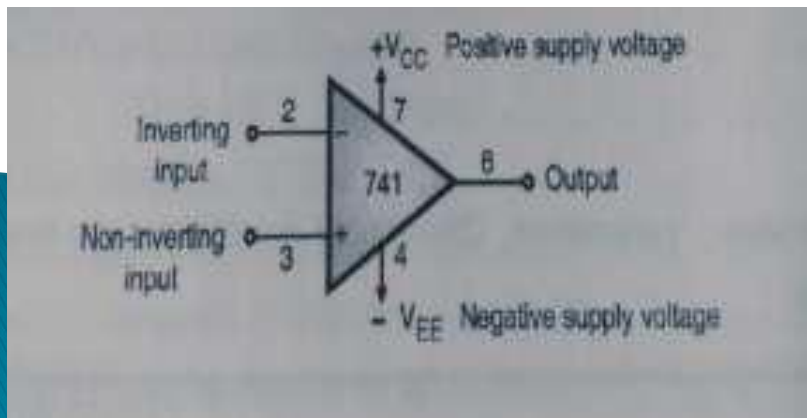

- An OP-AMP has a two input terminal, one output terminal and two supply voltage terminals.
- The input terminal marked with negative(-) sign is called as an inverting terminal .If we connect the input signal to this terminal then the amplified output signal is 180° out of phase with respect to input.
- The input terminal marked with positive (+) sign is called as Non-Inverting terminal. If the input is applied to this pin then the amplified output is in phase with the input.
- Offset null is used to nullify the offset voltage and pin no 8 is dummy pin.

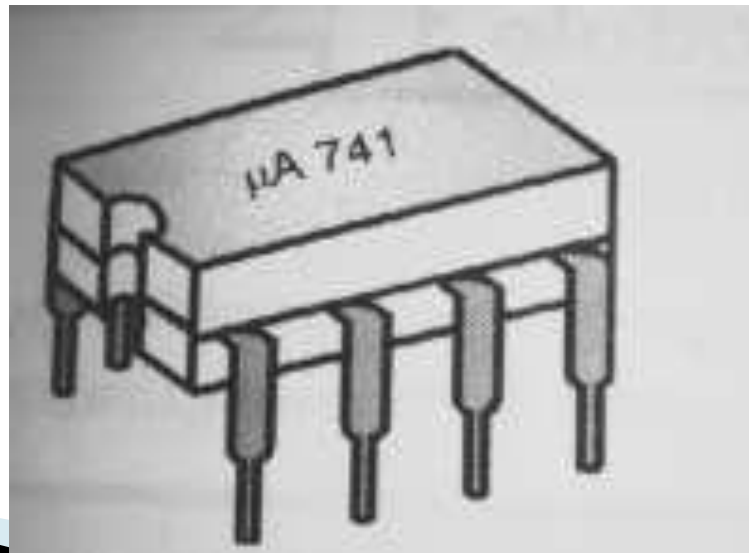

Block diagram

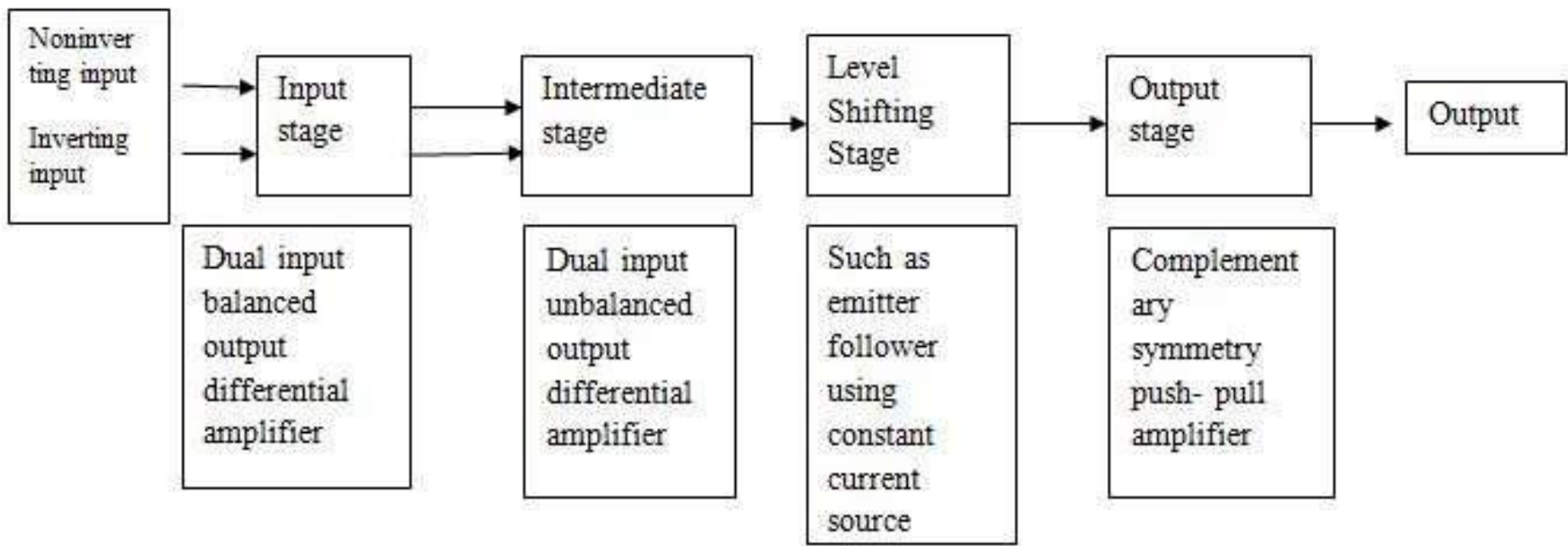

- **Input stage** provides most of the voltage gain of OP-AMP and decides input resistance.
 - **Intermediate stage** is another differential amplifier which is driven by the output of input stage.
 - Due to direct coupling between the first two stages, the input of level shifting is an amplified signal with some non zero dc level. **Level shifting stage** is used to bring this dc level to zero volts with respect to ground.
 - **Output stage** increase the current supplying capability of OP-AMP and also provides low output resistance.
- 

OP-AMP input modes

Single ended mode

If the input signal is applied to only one of the inputs and the other input terminal is connected to ground it is said to be operating in single ended mode

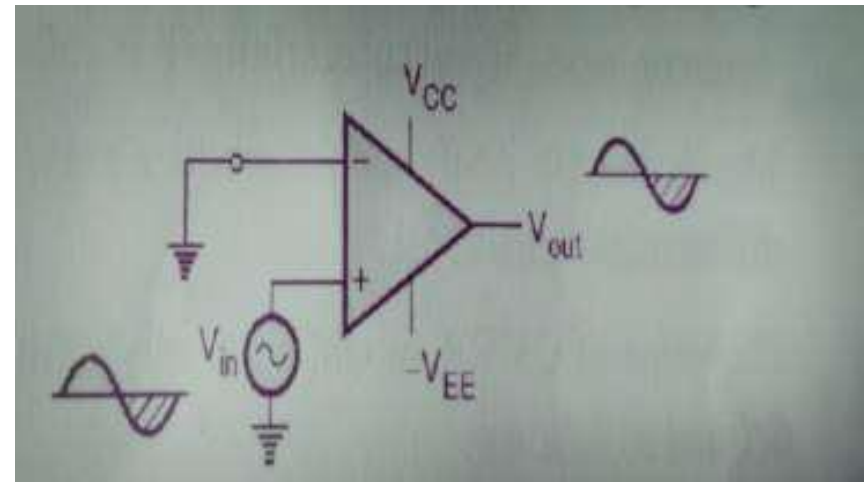
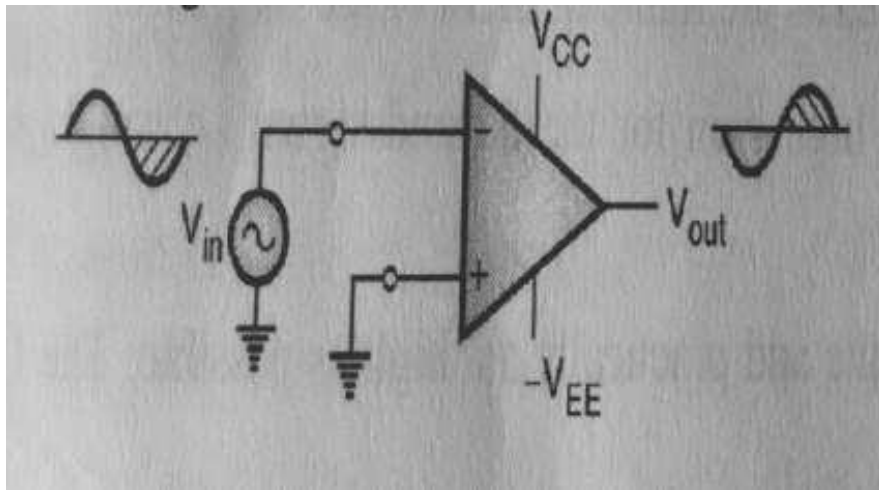

Differential mode/double ended

In differential mode, two opposite polarity signals are applied to the two inputs of an op amp. The difference between the input signals is amplified and appears at the output.

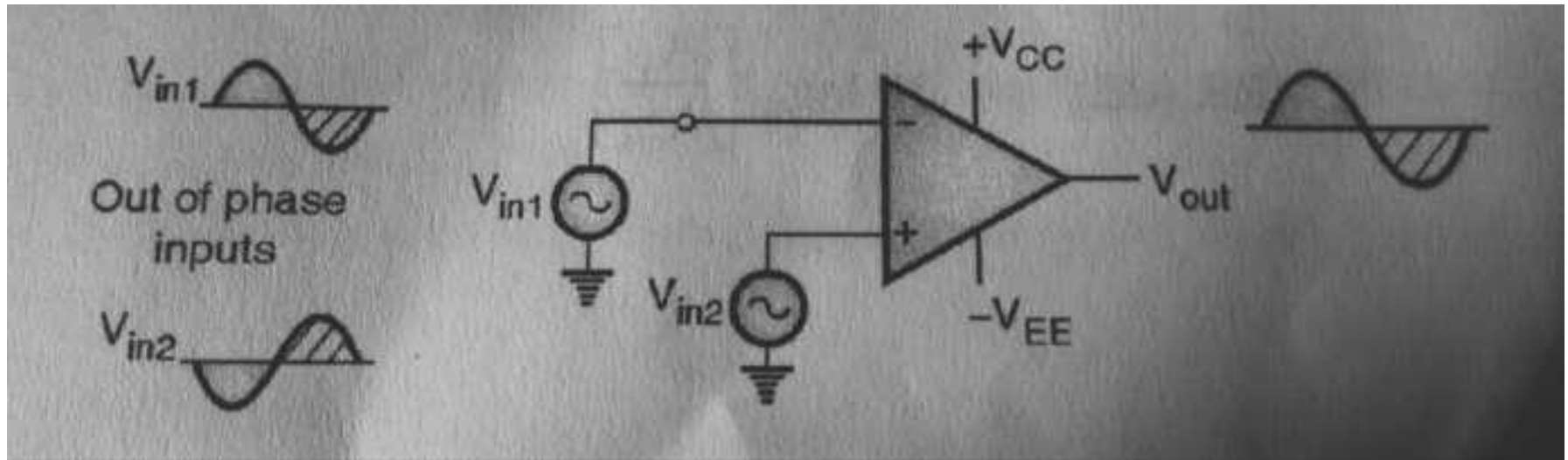

Common mode

In the common mode of operation, the same input signal is applied to both the input terminals. Ideally a zero voltage should be produced by the op amp.

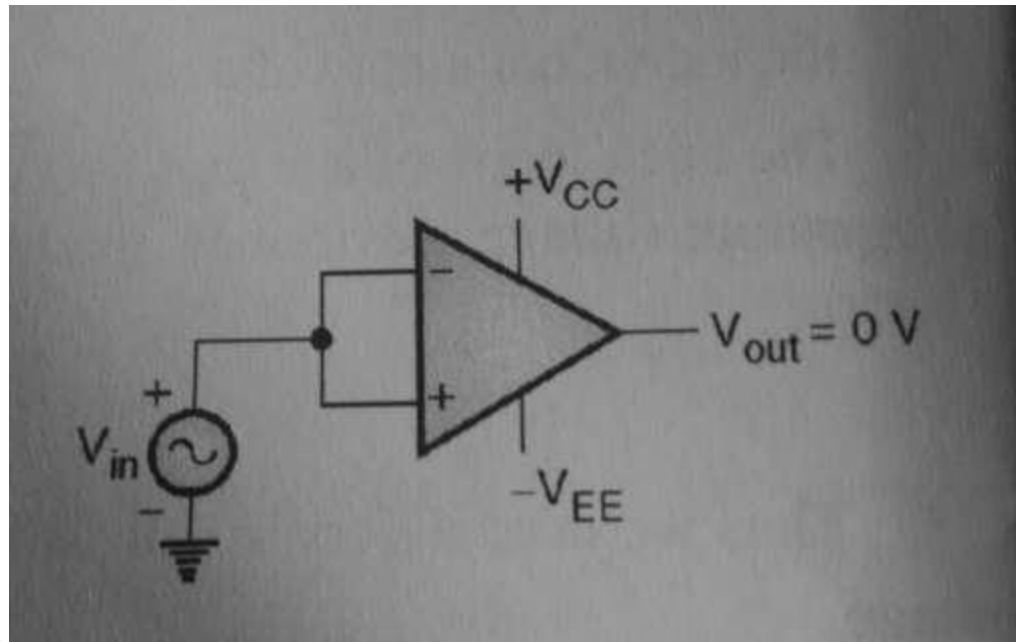

Comparison of ideal and practical OP-AMP

characteristics	Practical value	Ideal value
Voltage gain	2×10^5	∞
Input resistance	2M Ω	∞
Output resistance	75 Ω	0
Bandwidth	1 MHz	∞
CMRR	90 dB	∞
Slew rates	0.5V/ μ s	∞
PSRR	150 μ V/V	0
Input offset voltage	2mV	0
Input bias current	50 nA	0
Input offset current	6 nA	0

Configuration of op-amp

Open loop configuration

In open loop configuration, there is no feedback from output to input. The differential signal present between the inputs will be amplified by its open loop gain. ($A_v = 2 \times 10^5$).

- Therefore even for very small magnitude of differential voltage output will reach positive or negative saturation

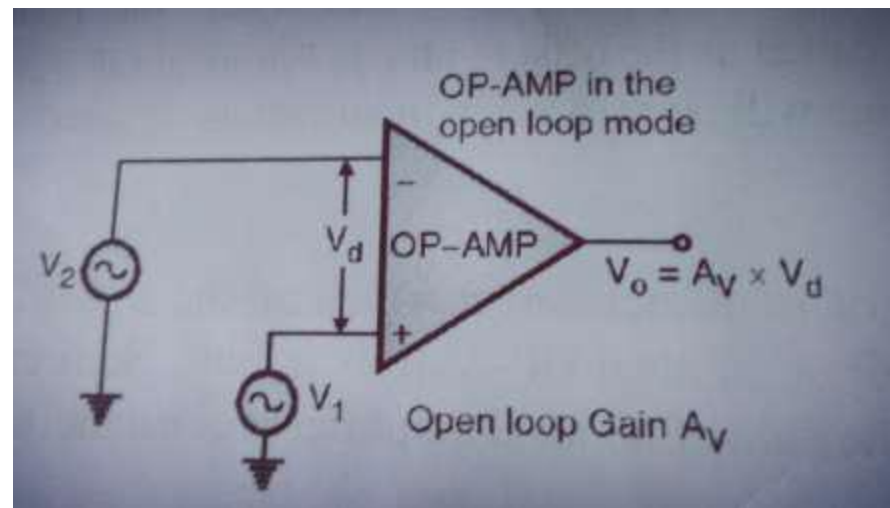

Why is OP-AMP not used as an amplifier in the open loop configuration?

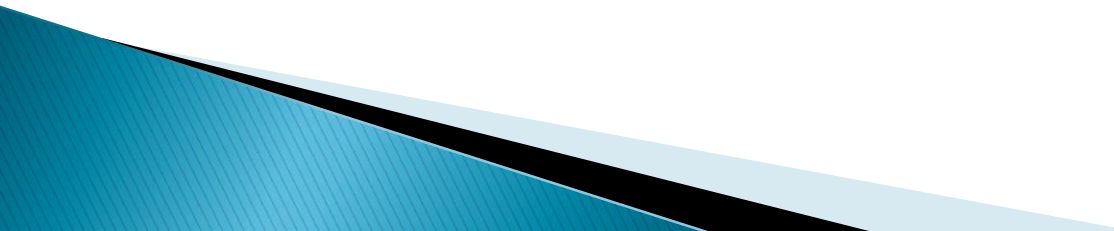
- Due to very open loop gain, distortion is introduced in the amplified output signal.
 - The open loop gain does not remain constant but varies with temperature and power supply as well due to mass production technique.
 - The bandwidth of an OP-AMP is very small almost equal to zero. For this reason the open loop OP-AMP is not used in practice as an amplifier
- 

Close loop configuration

In close loop configuration , a feedback is introduced i.e. a part of output is fed back to the input.

The feedback can be of the following two types:

1. **Positive feedback/regenerative feedback**
2. **Negative feedback/degenerative feedback**

Positive feedback

If the feedback signal and the input signal are in phase with each other then it is called as the positive feedback.

It is used in application such as oscillators and schmitt trigger or regenerative comparators.

Negative feedback

If the signal fed back to the input and the original input signal are 180° out of phase, then it is called as the negative feedback.

In application of op amp as an amplifier, the negative feedback is used.

Advantages of negative feedback

- It stabilizes gain
- Reduces the distortion
- Increases the bandwidth
- Reduces the effect of variations in temperature and supply voltage on the output of op amp

The only disadvantage of negative feedback is low gain

Concept of virtual short

- According to virtual short concept, the potential difference between the two input terminals of an op amp is almost zero.
- In other words both the terminals are approximately at the same potential.

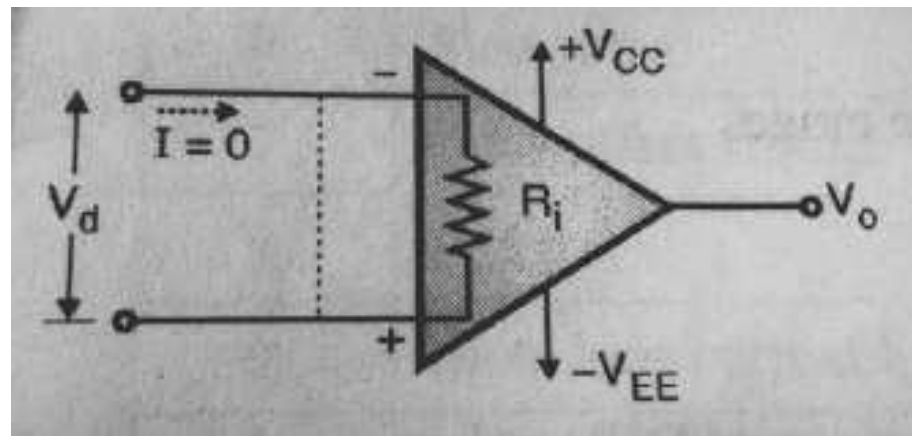

The input impedance of an OP-AMP is ideally infinite. Hence current flowing from one input terminal to the other will be zero.

- Thus the voltage drop across R_i will be zero and both the terminals will be at the same potential.
- Means they are virtually shorted to each other.

Virtual Ground

If one of the terminal of OP-AMP is connected to ground then due to the virtual short existing between the other input terminal, the other terminal is said to be at ground potential.

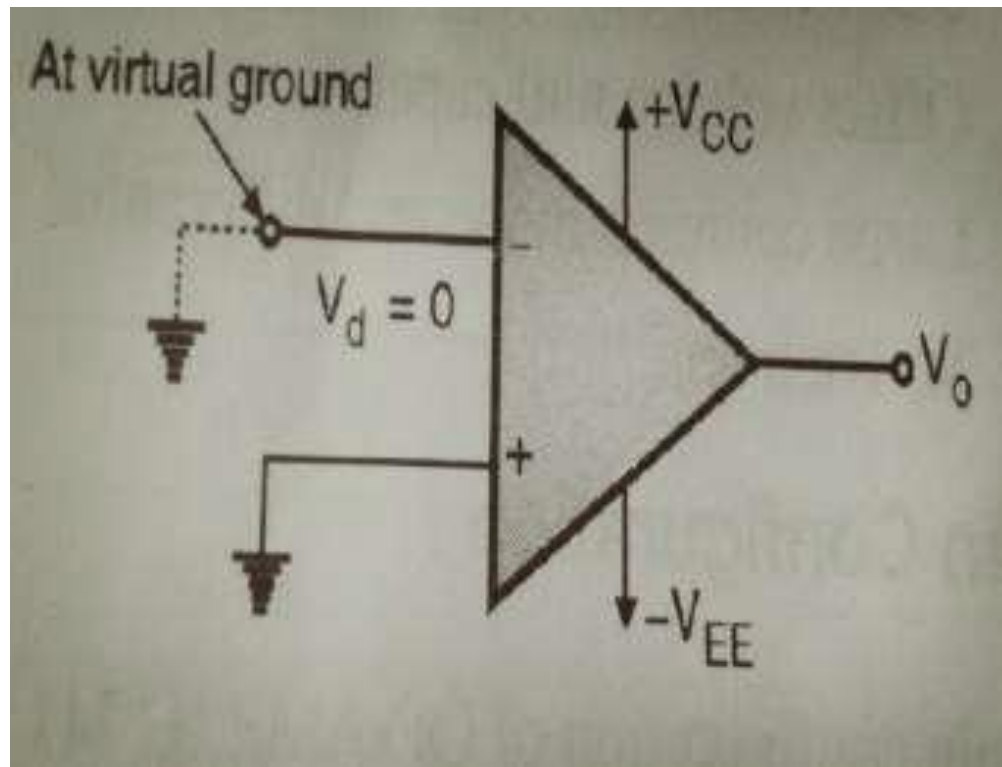

Zero input current

- As the input resistance of the ideal OP-AMP is infinite, the current flowing into its input terminal is zero.
- Even for the practical OP-AMPs, $R_{in}=2M\Omega$ which is very large. Hence for all the practical purposes we assume that the input current of an OP-AMP is zero.

Features of IC 741

- No frequency compensation required
- Short circuit protection
- Offset voltage null
- Large common mode and differential voltage ranges
- No latch ups

Some Useful links

<https://www.allaboutcircuits.com/video-lectures/basic-amplifier-configuration/>

<https://www.youtube.com/watch?v=vQQJuUN7n-w>

https://www.electronics-notes.com/articles/analogue_circuits/operational-amplifier-op-amp/non-inverting-amplifier.php

<https://www.youtube.com/watch?v=k0hfx9xsPzM>

THANK YOU